



# SERVICE MANUAL

# Universal MARINE DIESEL ENGINES

**M-25XPB**

**M-35B**

**M-40B**

PUBLICATION NO. 200554  
1st Edition/January 2001



WESTERBEKE CORPORATION • MYLES STANDISH INDUSTRIAL PARK  
150 JOHN HANCOCK ROAD, TAUNTON, MA 02780-7319 U.S.A.  
TEL: (508)823-7677 • FAX: (508)884-9688 • WEBSITE: WWW.WESTERBEKE.COM



Member National Marine Manufacturers Association

**CALIFORNIA  
PROPOSITION 65 WARNING**

Diesel engine exhaust and some of its constituents are known to the State of California to cause cancer, birth defects, and other reproductive harm.

**⚠ WARNING:**

*Exhaust gasses contain Carbon Monoxide, an odorless and colorless gas. Carbon Monoxide is poisonous and can cause unconsciousness and death. Symptoms of Carbon Monoxide exposure can include:*

- *Dizziness*
- *Throbbing in Temples*
- *Nausea*
- *Muscular Twitching*
- *Headache*
- *Vomiting*
- *Weakness and Sleepiness*
- *Inability to Think Coherently*

***IF YOU OR ANYONE ELSE EXPERIENCE ANY OF THESE SYMPTOMS, GET OUT INTO THE FRESH AIR IMMEDIATELY. If symptoms persist, seek medical attention. Shut down the unit and do not restart until it has been inspected and repaired.***



***This WARNING DECAL is provided by UNIVERSAL and should be fixed to a bulkhead near your engine or generator. UNIVERSAL also recommends installing CARBON MONOXIDE DETECTORS in the living/sleeping quarters of your vessel. They are inexpensive and easily obtainable at your local marine store.***

# SAFETY INSTRUCTIONS

## INTRODUCTION

Read these safety instructions carefully before servicing your engine. Most accidents are caused by failure to follow fundamental rules and precautions. Know when dangerous conditions exist and take the necessary precautions to protect yourself, your personnel, and your machinery.

The following safety instructions are in compliance with the American Boat and Yacht Council (ABYC) standards.

## PREVENT ELECTRIC SHOCK

**⚠ WARNING: Do not touch AC electrical connections while engine is running, or when connected to shore power. Lethal voltage is present at these connections!**

- Do not operate this machinery without electrical enclosures and covers in place.
- Shut off electrical power before accessing electrical equipment.
- Use insulated mats whenever working on electrical equipment.
- Make sure your clothing and skin are dry, not damp (particularly shoes) when handling electrical equipment.
- Remove wristwatch and all jewelry when working on electrical equipment.
- Do not connect utility shore power to vessel's AC circuits, except through a ship-to-shore double throw transfer switch. Damage to vessel's AC generator may result if this procedure is not followed.
- Electrical shock results from handling a charged capacitor. Discharge capacitor by shorting terminals together with an insulated tool.

## PREVENT BURNS — HOT ENGINE

**⚠ WARNING: Do not touch hot engine parts or exhaust system components. A running engine gets very hot!**

- Always check the engine coolant level at the coolant recovery tank.

**⚠ WARNING: Steam can cause injury or death!**

- In case of an engine overheat, allow the engine to cool before touching the engine or checking the coolant.

## PREVENT BURNS — FIRE

**⚠ WARNING: Fire can cause injury or death!**

- Prevent flash fires. Do not smoke or permit flames or sparks to occur near the carburetor, fuel line, filter, fuel pump, or other potential sources of spilled fuel or fuel vapors. Use a suitable container to catch all fuel when removing the fuel line, carburetor, or fuel filters.
- Do not operate with a Coast Guard Approved flame arrester removed. Backfire can cause severe injury or death.
- Do not operate with the air cleaner/silencer removed. Backfire can cause severe injury or death.
- Do not smoke or permit flames or sparks to occur near the fuel system. Keep the compartment and the engine clean and free of debris to minimize the chance of fire. Wipe up all spilled fuel and engine oil.
- Be aware — diesel fuel will burn.

## PREVENT BURNS — EXPLOSION

**⚠ WARNING: Explosions from fuel vapors can cause injury or death!**

- Follow re-fueling safety instructions. Keep the vessel's hatches closed when fueling. Open and ventilate cabin after fueling. Check below for fumes/vapor before running the blower. Run the blower for four minutes before starting your engine.
- All fuel vapors are highly explosive. Use extreme care when handling and storing fuels. Store fuel in a well-ventilated area away from spark-producing equipment and out of the reach of children.
- Do not fill the fuel tank(s) while the engine is running.
- Shut off the fuel service valve at the engine when servicing the fuel system. Take care in catching any fuel that might spill. DO NOT allow any smoking, open flames, or other sources of fire near the fuel system or engine when servicing. Ensure proper ventilation exists when servicing the fuel system.
- Do not alter or modify the fuel system.
- Be sure all fuel supplies have a positive shutoff valve.
- Be certain fuel line fittings are adequately tightened and free of leaks.
- Make sure a fire extinguisher is installed nearby and is properly maintained. Be familiar with its proper use. Extinguishers rated ABC by the NFPA are appropriate for all applications encountered in this environment.

# SAFETY INSTRUCTIONS

## ACCIDENTAL STARTING

**⚠ WARNING: Accidental starting can cause injury or death!**

- Disconnect the battery cables before servicing the engine. Remove the negative lead first and reconnect it last.
- Make certain all personnel are clear of the engine before starting.
- Make certain all covers, guards, and hatches are re-installed before starting the engine.

## BATTERY EXPLOSION

**⚠ WARNING: Battery explosion can cause injury or death!**

- Do not smoke or allow an open flame near the battery being serviced. Lead acid batteries emit hydrogen, a highly explosive gas, which can be ignited by electrical arcing or by lit tobacco products. Shut off all electrical equipment in the vicinity to prevent electrical arcing during servicing.
- Never connect the negative (-) battery cable to the positive (+) connection terminal of the starter solenoid. Do not test the battery condition by shorting the terminals together. Sparks could ignite battery gases or fuel vapors. Ventilate any compartment containing batteries to prevent accumulation of explosive gases. To avoid sparks, do not disturb the battery charger connections while the battery is being charged.
- Avoid contacting the terminals with tools, etc., to prevent burns or sparks that could cause an explosion. Remove wristwatch, rings, and any other jewelry before handling the battery.
- Always turn the battery charger off before disconnecting the battery connections. To avoid sparks from an accidental short circuit, always remove the negative lead first and reconnect it last when servicing the battery.

## BATTERY ACID

**⚠ WARNING: Sulfuric acid in batteries can cause severe injury or death!**

- When servicing the battery or checking the electrolyte level, wear rubber gloves, a rubber apron, and eye protection. Batteries contain sulfuric acid which is destructive. If it comes in contact with your skin, wash it off at once with water. Acid may splash on the skin or into the eyes inadvertently when removing electrolyte caps.

## TOXIC EXHAUST GASES

**⚠ WARNING: Carbon monoxide (CO) is a deadly gas!**

- Ensure that the exhaust system is adequate to expel gases discharged from the engine. Check the exhaust system regularly for leaks and make sure the exhaust manifolds are securely attached and no warping exists. Pay close attention to the manifold, water injection elbow, and exhaust pipe nipple.
- Be sure the unit and its surroundings are well ventilated.
- In addition to routine inspection of the exhaust system, install a carbon monoxide detector. Consult your boat builder or dealer for installation of approved detectors.
- For additional information refer to ABYC T-22 (educational information on Carbon Monoxide).

**⚠ WARNING: Carbon monoxide (CO) is an invisible odorless gas. Inhalation produces flu-like symptoms, nausea or death!**

- Do not use copper tubing in diesel exhaust systems. Diesel fumes can rapidly destroy copper tubing in exhaust systems. Exhaust sulfur causes rapid deterioration of copper tubing resulting in exhaust/water leakage.
- Do not install exhaust outlet where exhaust can be drawn through portholes, vents, or air conditioners. If the engine exhaust discharge outlet is near the waterline, water could enter the exhaust discharge outlet and close or restrict the flow of exhaust. Avoid overloading the craft.
- Although diesel engine exhaust gases are not as toxic as exhaust fumes from gasoline engines, carbon monoxide gas is present in diesel exhaust fumes. Some of the symptoms or signs of carbon monoxide inhalation or poisoning are:
  - Dizziness      Throbbing in temples
  - Headache      Muscular twitching
  - Nausea      Weakness and sleepiness
  - Vomiting      Inability to think coherently

## AVOID MOVING PARTS

**⚠ WARNING: Rotating parts can cause injury or death!**

- Do not service the engine while it is running. If a situation arises in which it is absolutely necessary to make operating adjustments, use extreme care to avoid touching moving parts and hot exhaust system components.

# SAFETY INSTRUCTIONS

- Do not wear loose clothing or jewelry when servicing equipment; tie back long hair and avoid wearing loose jackets, shirts, sleeves, rings, necklaces or bracelets that could be caught in moving parts.
- Make sure all attaching hardware is properly tightened. Keep protective shields and guards in their respective places at all times.
- Do not check fluid levels or the drive belt's tension while the engine is operating.
- Stay clear of the drive shaft and the transmission coupling when the engine is running; hair and clothing can easily be caught in these rotating parts.

## HAZARDOUS NOISE

 **WARNING: High noise levels can cause hearing loss!**

- Never operate an engine without its muffler installed.
- Do not run an engine with the air intake (silencer) removed.
- Do not run engines for long periods with their enclosures open.

 **WARNING: Do not work on machinery when you are mentally or physically incapacitated by fatigue!**

## OPERATORS MANUAL

Many of the preceding safety tips and warnings are repeated in your Operators Manual along with other cautions and notes to highlight critical information. Read your manual carefully, maintain your equipment, and follow all safety procedures.

## ENGINE INSTALLATIONS

Preparations to install an engine should begin with a thorough examination of the American Boat and Yacht Council's (ABYC) standards. These standards are a combination of sources including the USCG and the NFPA.

Sections of the ABYC standards of particular interest are:

- H-2 Ventilation
- P-1 Exhaust systems
- P-4 Inboard engines
- E-9 DC Electrical systems

All installations must comply with the Federal Code of Regulations (FCR).

## ABYC, NFPA AND USCG PUBLICATIONS FOR INSTALLING DIESEL ENGINES

Read the following ABYC, NFPA and USCG publications for safety codes and standards. Follow their recommendations when installing your engine.

**ABYC** (American Boat and Yacht Council)  
*Safety Standards for Small Craft*

Order from:

ABYC  
3069 Solomons Island Rd.  
Edgewater, MD 21037

**NFPA** (National Fire Protection Association)  
*Fire Protection Standard for Motor Craft*

Order from:

NFPA  
11 Tracy Drive  
Avon Industrial Park  
Avon, MA 02322

**USCG** (United States Coast Guard)  
*USCG 33CFR183*

Order from:

U.S. Government Printing Office  
Washington, D.C. 20404

# INSTALLATION

When installing UNIVERSAL engines, it is important that strict attention be paid to the following information:

## CODES AND REGULATIONS

Federal regulations, ABYC guidelines and safety codes must be complied with when installing engines and generators in a marine environment.

## SIPHON-BREAK

For installations where the exhaust manifold/water-injected exhaust elbow is close to or will be below the vessel's waterline, provisions *must* be made to install a siphon-break in the raw water supply hose to the exhaust elbow. This hose *must* be looped a minimum of 20 in (51 cm) above the vessel's waterline. *Failure to use a siphon-break when the exhaust manifold injection port is at or below the load waterline will result in raw water damage to the engine and possible flooding of the boat.*

If you have any doubt about the position of the water-injected exhaust elbow relative to the vessel's waterline under any of the vessel's various operating conditions or when the vessel is not underway, *install a siphon-break*. This precaution is necessary to protect your engine.

**NOTE:** *A siphon-break requires periodic inspection and cleaning to ensure proper operation. Failure to properly maintain a siphon-break can result in catastrophic engine damage. Consult the siphon-break manufacturer for a proper maintenance schedule.*

## EXHAUST SYSTEM

The exhaust hose must be certified for marine use. The system must be designed to prevent water from entering the exhaust under any sea conditions and at any angle of the vessel's hull.

**A detailed 40-page Marine Installation Manual covering gasoline and diesel, engines and generators, is available from your UNIVERSAL dealer.**



# TABLE OF CONTENTS

Introduction.....	2
Parts Identification.....	3
Specifications.....	4
Testing for Overhaul.....	6
Engine Troubleshooting.....	7
Service Standards.....	15
Engine Description.....	18
Engine Disassembly & Reassembly.....	21
Engine Service.....	32
Engine Adjustments.....	43
Exhaust Manifold Service.....	47
Lubrication System Description.....	48
Lubrication System Service.....	50
Cooling System Description.....	52
Cooling System Service.....	54
Fuel System Description.....	56
Fuel System Disassembly & Reassembly.....	60
Fuel System Service.....	61
Admiral Control Panel.....	63
Captain Control Panel.....	64
Control Panel Troubleshooting.....	65
Glow Plug Service.....	67
Starter Service.....	68
Mando Alternator Service.....	72
Prestolite Alternator Service.....	82
Wiring Diagram #39144.....	94
Wiring Schematic #39144.....	95
Wiring Diagram #200360 – Catalina Yachts.....	96
Wiring Schematic #200360 – Catalina Yachts.....	97
Hurth HBW Transmissions.....	98
Transmission Troubleshooting.....	101
Special Tools.....	102
Torques.....	104
Standard Hardware; Sealants & Lubricants.....	105
Metric Conversions.....	106
Standard and Metric Conversion Data.....	107
Index.....	108

# INTRODUCTION

## ENGINE OVERHAUL

This service manual contains detailed information relating to the servicing and overhaul of the Universal M-25XPB, M-35B and M-40B marine diesel engines. Information about the construction and function of the various systems and components can be found in the *Description* sections. For the major engine overhaul procedure, refer to the *ENGINE DISASSEMBLY & REASSEMBLY* and *ENGINE SERVICE* sections. Additional service information for specific components and systems may be found by referring to the *TABLE OF CONTENTS* and the *INDEX*. Refer also to your UNIVERSAL parts Catalog.

These service procedures are intended for the guidance of suitably equipped and staffed marine engine service and rebuilding facilities, and should only be undertaken by such facilities and their personnel.

The service information in this manual generally applies to all three models covered by this manual. The individual models will only be noted where information does not apply to all three models.

## PRODUCT SOFTWARE

Product software (tech data, parts lists, manuals, brochures and catalogs) provided from sources other than UNIVERSAL are not within UNIVERSAL'S CONTROL.

UNIVERSAL CANNOT BE RESPONSIBLE FOR THE CONTENT OF SUCH SOFTWARE, MAKES NO WARRANTIES OR REPRESENTATIONS WITH RESPECT THERETO, INCLUDING ACCURACY, TIMELINESS OR COMPLETENESS THEREOF AND WILL IN NO EVENT BE LIABLE FOR ANY TYPE OF DAMAGE OR INJURY INCURRED IN CONNECTION WITH OR ARISING OUT OF THE FURNISHING OR USE OF SUCH SOFTWARE.

UNIVERSAL customers should also keep in mind the time span between printings of UNIVERSAL product software and the unavoidable existence of earlier UNIVERSAL manuals. Product software provided with UNIVERSAL products, whether from UNIVERSAL or other suppliers, must not and cannot be relied upon exclusively as the definitive authority on the respective product. It not only makes good sense but is imperative that appropriate representatives of UNIVERSAL or the supplier in question be consulted to determine the accuracy and currentness of the product software being consulted by the customer.

## NOTES, CAUTIONS AND WARNINGS

As this manual takes you through the service procedures and troubleshooting of your marine engine, critical information will be highlighted by *NOTES*, *CAUTIONS*, and *WARNINGS*. An explanation follows:

**NOTE:** *An operating procedure essential to note.*

**CAUTION:** *Procedures, which if not strictly observed, can result in the damage or destruction of your engine.*

**WARNING:** *Procedures, which if not properly followed, can result in personal injury or loss of life.*

## CUSTOMER IDENTIFICATION CARD



Customer Identification

UNIVERSAL OWNER

MAIN STREET

HOMETOWN, USA

Model M-35B

Ser. #XXXX-D704

Expires 4/24/01

The UNIVERSAL engine serial number is an alphanumeric number that can assist in determining the date of manufacture of your UNIVERSAL engine. The manufacturer's date code is placed at the end of the engine serial number and consists of a character followed by three numbers. The character indicates the decade (D=1990s, E=2000s), the first number represents the year in the decade, and the second and third numbers represent the month of manufacture.

## ORDERING PARTS/SERIAL NUMBER LOCATION

Whenever replacement parts are needed, always provide the engine model number and engine serial number as they appear on the silver and black identification nameplate located on the side of the engine's exhaust manifold. The engine serial number can also be found stamped into the engine block on the left side of the engine below the cylinder head cover. You must provide us with this information so we may properly identify your engine. In addition, include a complete part description and part number for each part needed (see the separately furnished Parts List). Also insist upon UNIVERSAL packaged parts because *will fit* or generic parts are frequently not made to the same specifications as original equipment.



**NOTE:** *Component locations in this manual are referenced from the front of the engine which is the pulley/drive belt end. Left and right sides are determined as follows: imagine straddling the engine, facing in the same direction as the front of the engine: the left side is at your left, the right side is at your right. The cylinder number sequence starts with the No. 1 cylinder located at the front of the engine.*





# PARTS IDENTIFICATION

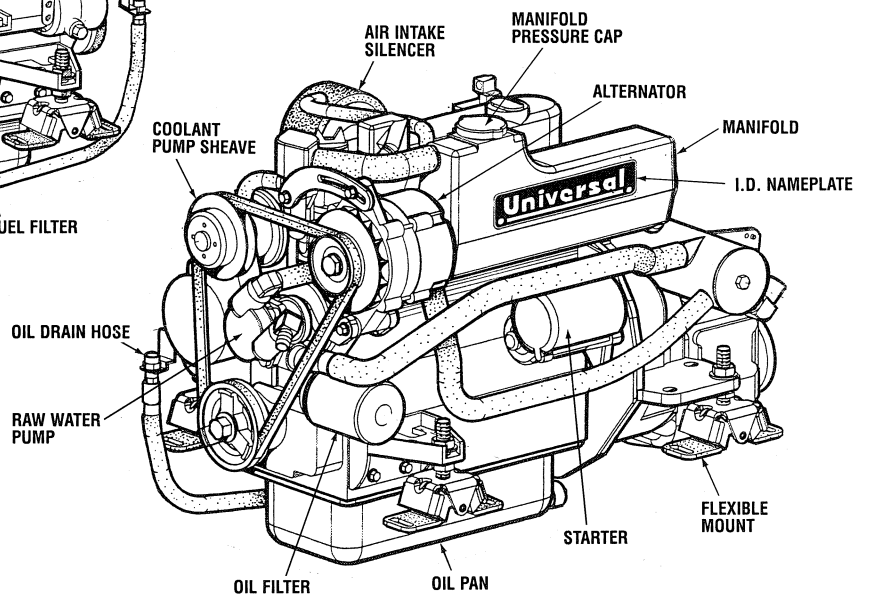
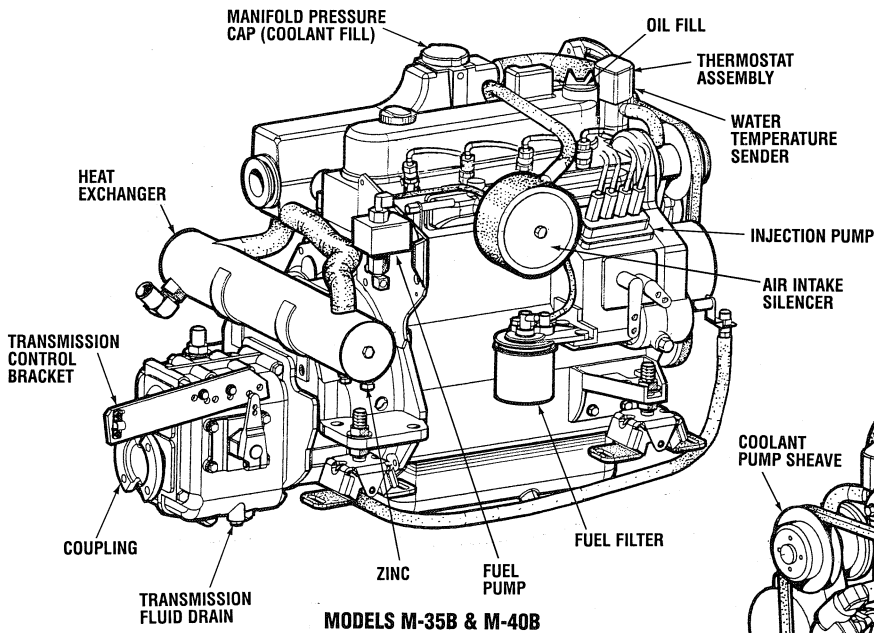
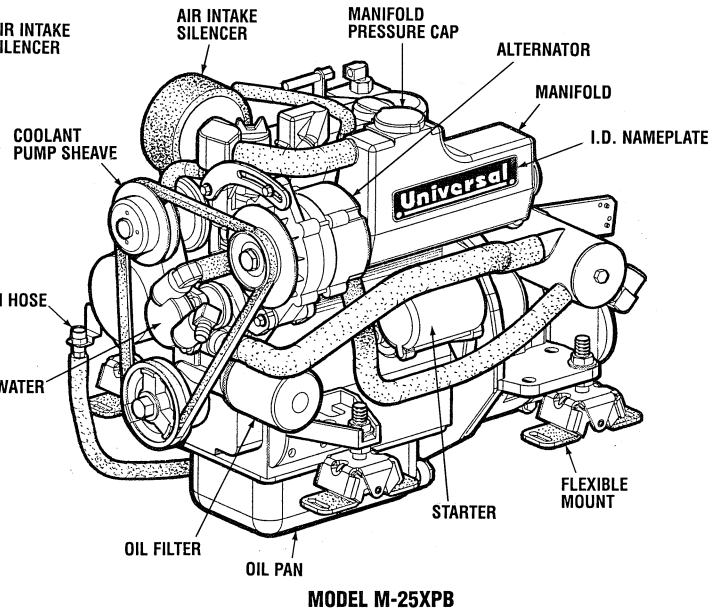
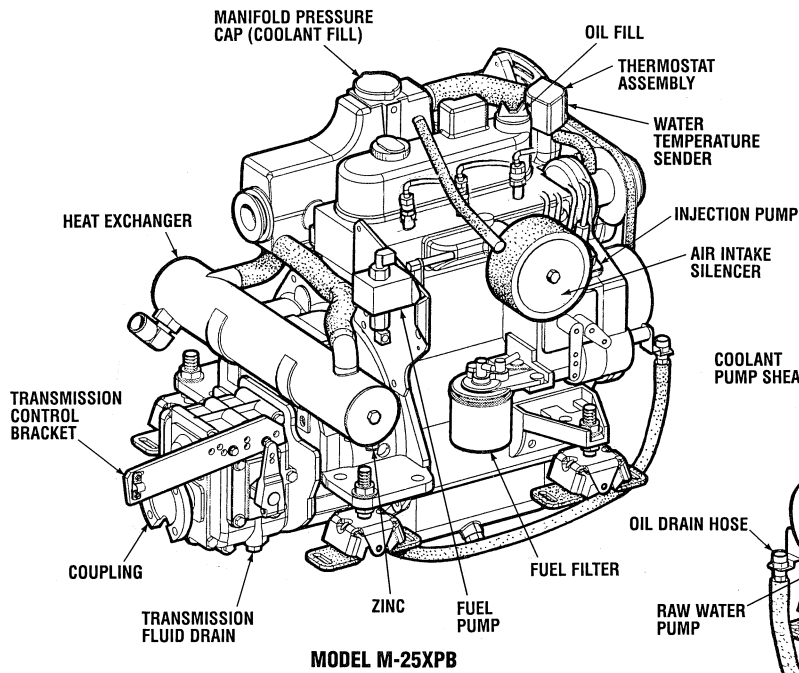

# SPECIFICATIONS

	<b>UNIVERSAL MODEL</b>		
	<b>M-25XPB</b>	<b>M-35B</b>	<b>M-40B</b>
<b>ENGINE</b>			
Engine Type	Diesel, four-cycle, fresh water cooled, vertical, in-line overhead valve mechanism		
Horsepower	26 @ 3000 rpm	35 @ 3000 rpm	37.5 @ 3000 rpm
Cylinders	3	4	
Aspiration	Naturally aspirated		
Bore & Stroke	2.99 x 2.90 in. (76.0 x 73.6 mm)		3.07 x 3.09 in. (78.0 x 78.4 mm)
Combustion Chamber	Spherical type; three vortex combustion system		
Displacement	61.2 cu. in. (1.0 liters)	81.47 cu. in. (1.335 liters)	91.41 cu. in. (1.498 liters)
Compression Ratio	23:1		
Firing Order	1 - 2 - 3	1 - 3 - 4 - 2	
Crankshaft Direction of Rotation	Counterclockwise as viewed from flywheel end		
Maximum Torque	47 ft-lbs (6.5 kg-m) @ 2440 rpm	62 ft-lbs (8.6 kg-m) @ 2460 rpm	73 ft-lbs (10.1 kg-m) @ 2180 rpm
Dry Weight, with Transmission	295 lbs (133.8 kg)	352 lbs (159.0 kg)	356 lbs (161.5 kg)
Dimensions	Length 28.4 in. (721.4 mm) Width 18.9 in. (480.1 mm) Height 22.1 in. (561.3 mm)	Length 32.7 in. (830.6 mm) Width 18.9 in. (480.1 mm) Height 22.0 in. (558.9 mm)	Length 33.2 in. (843.3 mm) Width 18.9 in. (480.1 mm) Height 22.1 in. (561.3 mm)
Maximum Angle of Installation	Not to exceed 14° (24 rad.)		
Maximum Angle of Rotation	Not to exceed 25° (44 rad.)		
Engine Speed	Idle speed M-25XPB: 1,000 – 1,200 rpm; M-35B, M-40B: 800 – 1,000 rpm Cruise Speed M-25XPB, M-35B, M-40B: 2,000 – 2,500 rpm		
Engine Timing	18° (0.314 rad.) before T.D.C.		
Engine Stop	Manual		
<b>LUBRICATION SYSTEM</b>			
Type of System	Forced lubrication by gear pump		
Oil Grade	API Specification CF or CG-4, SAE 30, 10W-30, 15W-40		
Oil Filter	Full-flow, spin-on filter element		
Lubricant Capacity	4.0 qts/3.8 liters	4.5 qts (4.3 liters)	
Operating Oil Pressure (Engine Hot)	40-60 psi (276-414 kPa) at rated speed		
<b>FUEL SYSTEM</b>			
Type of System	Open flow, self priming		
Fuel	No. 2 Diesel Oil, cetane rating of 45 or higher		
Fuel Injection Pump	Bosch in-line plunger type		
Fuel Injectors	Bosch throttle type		
Governor	Centrifugal mechanical type		
Fuel Lift Pump	12 volt 5 ft. lift capacity, solid state		
Fuel Filter	Full flow, spin-on element		
Fuel Supply & Return Piping	1/8 in. I.D. (3.18 mm) minimum; 3/8 in. I.D. (9.52 mm) maximum		
Typical Fuel Consumption @ 2500 rpm	1.0 gal./hr (3.8 liters/hr)	1.3 gal./hr (4.9 liters/hr)	1.4 gal./hr (5.3 liters/hr)
Air Intake Silencer	Cleanable, replaceable filter element		
Air Flow @ 3000 rpm (Engine Combustion)	53.1 cfm (1503.5 lpm)	70.7 cfm (2001.8 lpm)	79.3 cfm (2245.3 lpm)

*(continued)*



# SPECIFICATIONS

	<b>UNIVERSAL MODEL</b>		
	<b>M-25XPB</b>	<b>M-35B</b>	<b>M-40B</b>
<b>COOLING SYSTEM</b>			
Type of System	Fresh water cooled block, thermostatically controlled with raw water heat exchanger and centrifugal fresh water pump		
Operating Temperature	170° – 190° F (77° – 88°C)		
Coolant Pump	Centrifugal type, metal impeller, belt-driven		
Coolant Capacity	4.0 qts (3.8 liters)	6.0 qts (5.6 liters)	4.5 qts (4.3 liters)
Raw Water Pump	Positive displacement, neoprene impeller, gear driven		
Raw Water Flow @ 3000 rpm before discharge into exhaust elbow	7.0 gal/min (26.5 liters/min)		
<b>ELECTRICAL SYSTEM</b>			
Starting Battery	12 volt DC, negative ground		
Battery Capacity	400 – 600 cold cranking amps (CCA)		
Alternator/Regulator	Mando, 51 amp, 12 volt, belt-driven, with internal regulator		
Starter Motor	12 volt, reduction gear, actuated shift, with solenoid		
Starting Aid	12 volt sheathed type glow plugs		
<b>TRANSMISSION</b>			
Model	HURTH HBW-50	HURTH HBW-100	HURTH HBW-150
Type of Transmission	Case-hardened helical gears, with a servo-operated multiple disc clutch		
Gear Ratio Forward (Std)	2.05:1	1.79:1	1.88:1
Propeller Shaft Rotation	Right hand – standard transmission		
Lubrication Fluid	ATF type A Dextron II or Dextron III		
Transmission Sump Capacity	0.37 qt. (0.35 liter)		0.58 qt. (0.56 liter)

# TESTING FOR OVERHAUL

## HOW TO DETERMINE WHEN TO OVERHAUL THE ENGINE

### Cause of Low Compression

Generally, the time at which an engine should be overhauled is determined by various conditions such as lowered engine power output, decreased compression pressure, and increased fuel and oil consumption. The lowered engine power output, in the case of diesel engines, is not necessarily due to trouble with the engine itself, but is sometimes caused by injector nozzle wear or injection pump wear. It is most reasonable to judge by a decrease in compression pressure. The decrease in compression pressure is caused by many factors. It is, therefore, necessary to determine a cause or causes on the basis of data produced by periodic inspection and maintenance. Oil analysis on a seasonal basis is a good means of monitoring engine internal wear. When caused by worn cylinders or piston rings, the following symptoms will occur:

- Low engine power output
- Increased fuel consumption
- Increased oil consumption
- Hard engine starting
- Noisy engine operation

These symptoms often appear together. Increased fuel consumption and hard engine starting can also result from excessive fuel injection, improper injection timing, and wear of the injection pump and nozzles. They are also caused by defective electrical components such as the battery, alternator, starter and glow plugs. Therefore it is desirable to judge the optimum engine overhaul time by the lowered compression pressure caused by worn cylinders and piston rings plus increased oil consumption. In diesel engines, satisfactory combustion is obtained only under sufficient compression pressure. If an engine lacks compression pressure, incomplete combustion of fuel will take place even if other parts of the engine are operating properly. To determine the period of engine overhaul, it is important to measure the engine compression pressure regularly. At the same time, the engine speed at which the measurement of compression pressure is made should be checked because the compression pressure varies with engine rpm. The engine rpm can be measured at the front end of the crankshaft.

### Measuring Compression Pressure

To check the compression pressure, see *ENGINE COMPRESSION TEST* under *ENGINE ADJUSTMENTS*.

**NOTE:** Do not guess the conditions of other cylinders from a result of testing one cylinder. Be sure to measure the compression pressure for each cylinder. Look for cylinders with dramatically (at least 20%) lower compression than the average of the other cylinders. If the weak cylinder is flanked by healthy cylinders, the problem is either valve- or head-gasket related. Very low compression in an adjacent cylinder indicates gasket failure. Abnormally high readings on all cylinders indicate heavy carbon accumulations, a condition that might be accompanied by high pressures and noise.

**NOTE:** In case of severe vibrations and detonation noise, have the injectors overhauled by an authorized fuel injection service center. Poor fuel quality, contaminants, and loss of positive fuel pressure to the injection pump will result in injector faults.

### OVERHAUL CONDITIONS

Compression pressure tends to increase a little in a new engine until the piston rings and valve seats have been broken in. Thereafter, it decreases gradually with the progressive wear of these parts.

When the decrease of compression pressure reaches its limit (see *SERVICE STANDARDS*), the engine must be overhauled. The engine also requires an overhaul when oil consumption is high, when blowby is evident, and when compression values are at a minimum or below.

**NOTE:** Refer to the *SERVICE STANDARDS* chart during an engine overhaul. It gives the measurements and values for the repair or replacement of the engine components.

**NOTE:** The *ENGINE TROUBLESHOOTING* section may be helpful in determining the need for an engine overhaul.

# ENGINE TROUBLESHOOTING

The following troubleshooting table describes certain problems relating to engine service, the probable causes of these problems, and the recommendations to overcome these problems.

**NOTE:** *The engine's electrical system is protected by a 20 ampere manual reset circuit breaker located on a bracket. The preheat solenoid is mounted on the same bracket.*

PROBLEM	PROBABLE CAUSE	VERIFICATION/REMEDY
<b>HARD STARTING</b>	<b>LOW CRANKING SPEED</b> 1. Engine oil viscosity too high. 2. Run-down battery. 3. Worn battery. 4. Battery terminals loosely connected. 5. Defective starter.	1. Replace engine oil with less viscous oil. 2. Recharge battery. 3. Replace battery. 4. Clean terminals and tighten cables. 5. Repair or replace starter.
	<b>DEFECTIVE FUEL INJECTION SYSTEM</b> 1. No fuel at injectors. <b>a.</b> No fuel in fuel tank and/or fuel shutoff. <b>b.</b> Fuel filter clogged. <b>c.</b> Injection pump faulty. 2. Fuel injectors faulty; inadequate spray. 3. Low injection pressure. 4. Injection timing incorrect. 5. Poor quality fuel. 6. Water and/or air in fuel system.	1. Check <b>a.</b> through <b>e.</b> <b>a.</b> Fill fuel tank. Open shutoff and bleed system. <b>b.</b> Replace filter and bleed. <b>c.</b> Inspect pump. Repair or replace pump as needed. 2. Remove and test nozzles. Repair nozzles as needed. 3. Adjust injection pressure. 4. Check and adjust timing. 5. Drain and replace with proper fuel. 6. Remove water and/or bleed air from fuel system. Check fuel system for leaks and fuel tank for water contamination.
	<b>MAIN ENGINE TROUBLES</b> 1. Low compression. <b>a.</b> Leaking compression from fuel injector gasket. <b>b.</b> Incorrect valve clearance. <b>c.</b> Inadequate contact of valve seat. <b>d.</b> Valve stem seized. <b>e.</b> Weak or broken valve spring. <b>f.</b> Bent push rod. <b>g.</b> Compression leaks through cylinder head gasket. <b>h.</b> Cracked or worn piston. <b>i.</b> Piston ring seized. <b>j.</b> Worn piston ring or cylinder liner. <b>k.</b> Cracked or distorted cylinder head. <b>l.</b> Fuel camshaft worn. 2. Carbon accumulation in combustion chamber.	1. Check <b>a.</b> through <b>k.</b> <b>a.</b> Tighten fuel injector or replace gasket. <b>b.</b> Adjust valve clearance. <b>c.</b> Lap valve. <b>d.</b> Replace valve and valve guide. <b>e.</b> Replace valve spring. <b>f.</b> Replace push rod. <b>g.</b> Replace gasket. <b>h.</b> Replace piston. <b>i.</b> Replace piston and piston ring. <b>j.</b> Replace piston ring or cylinder liner. <b>k.</b> Replace cylinder head. <b>l.</b> Replace fuel camshaft. 2. Clean.

(continued)

# ENGINE TROUBLESHOOTING

PROBLEM	PROBABLE CAUSE	VERIFICATION/REMEDY
<b>ENGINE IDLING TOO LOW</b>	<ol style="list-style-type: none"> <li>1. Idle speed too low.</li> <li>2. Fuel filter clogged.</li> <li>3. Incorrect injection pump timing.</li> <li>4. High pressure injection line leaking.</li> <li>5. Fuel injector leaking at sealing gasket in head.</li> <li>6. Injection nozzle not operating properly.</li> <li>7. Engine air intake obstructed.</li> </ol>	<ol style="list-style-type: none"> <li>1. Adjust idle stop as needed.</li> <li>2. Replace filter and bleed fuel system.</li> <li>3. Check timing and adjust as needed.</li> <li>4. Slacken attaching nut and retighten.</li> <li>5. Retighten injector and/or replace sealing washer.</li> <li>6. Check nozzle and adjust as needed.</li> <li>7. Check air intake silencer and air flow into engine compartment.</li> </ol>
<b>ROUGH IDLING</b>	<p style="text-align: center;"><b>MALFUNCTION OF ENGINE-RELATED COMPONENTS</b></p> <ol style="list-style-type: none"> <li>1. Improper valve clearance.</li> <li>2. Poor valve to valve seat contact.</li> <li>3. Failure of cylinder head gasket.</li> <li>4. Governor malfunctioning.</li> </ol>	<ol style="list-style-type: none"> <li>1. Adjust clearance.</li> <li>2. Repair or replace valve.</li> <li>3. Replace gasket.</li> <li>4. Repair governor.</li> </ol>
	<p style="text-align: center;"><b>FUEL INJECTION SYSTEM PROBLEM</b></p> <ol style="list-style-type: none"> <li>1. Faulty idling speed.</li> <li>2. Faulty injection timing.</li> <li>3. Clogged fuel line or fuel filter.</li> <li>4. Leak in fuel line or fuel filter.</li> <li>5. Air in injector, fuel line, injection pump, fuel filter or fuel filter/water separator.</li> <li>6. Seized or leaky delivery valve.</li> <li>7. Faulty injection starting pressure.</li> <li>8. Injection nozzle malfunction.</li> <li>9. Feed pump malfunction.</li> <li>10. Injection pump malfunction.</li> </ol>	<ol style="list-style-type: none"> <li>1. Adjust idling speed.</li> <li>2. Adjust injection timing.</li> <li>3. Clean fuel line or replace fuel filter.</li> <li>4. Repair fuel line or replace fuel filter.</li> <li>5. Bleed air.</li> <li>6. Clean or replace delivery valve.</li> <li>7. Adjust starting pressure.</li> <li>8. Clean or replace injection nozzle.</li> <li>9. Clean or replace feed pump.</li> <li>10. Take to a fuel injection pump service facility, or replace the pump.</li> </ol>
<b>ENGINE SLOWS AND STOPS</b>	<ol style="list-style-type: none"> <li>1. Fuel lift pump failure.</li> <li>2. Switches and/or wiring loose or disconnected.</li> <li>3. Fuel starvation.</li> <li>4. 20 amp circuit breaker tripping.</li> <li>5. Exhaust system is restricted.</li> <li>6. Water in fuel.</li> </ol>	<ol style="list-style-type: none"> <li>1. Check fuel lift pump operation.</li> <li>2. Inspect wiring for short circuits and loose connections. Inspect switches for proper operation.</li> <li>3. Check fuel supply, fuel valves, fuel lift pump.</li> <li>4. Check for high DC amperage draw during operation. Ensure breaker is not overly sensitive to heat which would cause tripping.</li> <li>5. Check for blockage, collapsed hose, carbon buildup at exhaust elbow.</li> <li>6. Pump water from fuel tank(s); change filters and bleed fuel system.</li> </ol>

*(continued)*

# ENGINE TROUBLESHOOTING

PROBLEM	PROBABLE CAUSE	VERIFICATION/REMEDY
<b>LOW OUTPUT</b>	<b>LOW COMPRESSION</b>	See <i>Low Compression</i> under <i>HARD STARTING</i> .
	<b>INJECTION SYSTEM OUT OF ADJUSTMENT</b> 1. Incorrect injection timing. 2. Insufficient injection. 3. Low injection pressure.	1. Adjust injection timing. 2. Repair or replace injection pump. 3. Check injection nozzle and adjust pressure.
	<b>INSUFFICIENT FUEL</b> 1. Air trapped in fuel system. 2. Clogged filter. 3. Contaminated or inferior fuel. 4. Contaminated fuel tank.	1. Bleed and check for source. 2. Clean or replace filter element. 3. Purge fuel system and replace with quality fuel. 4. Clean fuel tank.
	<b>OVERHEATING</b> 1. Low coolant level. 2. Loose V-belt. 3. Incorrect injection timing. 4. Low engine oil level.	1. Add coolant. 2. Adjust or replace V-belt. 3. Adjust injection timing. 4. Add engine oil.
	<b>OTHER</b> 1. Insufficient intake air.	1. Increase engine compartment air supply.
<b>KNOCKING</b>	<b>ENGINE KNOCKS WITHOUT MUCH SMOKE</b> 1. Main engine troubles. a. Overheated cylinder. b. Carbon deposits in cylinder. 2. Injection timing too early. 3. Injection pressure too high. 4. Improper fuel.	1. Check <b>a.</b> and <b>b.</b> a. See <i>ENGINE OVERHEATS/SHUTS DOWN; LOW OUTPUT</i> . b. Clean. 2. Correct the timing. 3. Correct the pressure. 4. Replace with proper fuel.
	<b>KNOCKING WITH DARK SMOKE</b> 1. Poor compression. 2. Injection pump malfunctioning. 3. Nozzle malfunctioning. a. Poor spray. b. Chattering. c. After-injection drip. d. Nozzle needle valve seized.	1. See <i>Low Compression</i> under <i>HARD STARTING</i> . 2. Adjust/Repair. 3. Check <b>a.</b> through <b>d.</b> a. Clean or replace nozzle. b. Repair or replace nozzle. c. Repair or replace nozzle. d. Replace needle valve.
<b>ABNORMAL SOUND OR NOISE</b>	<b>CRANKSHAFT AND MAIN BEARING</b> 1. Badly worn main bearing. 2. Badly worn crankshaft. 3. Melted bearing. 4. Excessive crankshaft end play.	1. Replace bearing and grind crankshaft. 2. Grind crankshaft. 3. Replace bearing and check lubrication system. 4. Repair or replace crankshaft.

# ENGINE TROUBLESHOOTING

PROBLEM	PROBABLE CAUSE	VERIFICATION/REMEDY
<b>ABNORMAL SOUND OR NOISE (Cont'd)</b>	<b>CONNECTING ROD AND CONNECTING ROD BEARING</b> 1. Worn connecting rod big end bearing. 2. Worn crankpin. 3. Bent connecting rod. 4. Excessive connecting rod bearing oil clearance. 5. Connecting rod bearing seized or heat-damaged.	1. Replace bearing. 2. Grind crankshaft. 3. Correct bend or replace. 4. Repair or replace bearing. 5. Replace bearing.
	<b>PISTON, PISTON PIN, PISTON RING, CYLINDER LINER</b> 1. Worn cylinder liner. 2. Worn piston or piston pin. 3. Piston seized. 4. Piston seized and ring worn or damaged.	1. Repair or replace liner. 2. Replace piston. 3. Replace piston and rebore cylinder. 4. Replace piston and rings.
	<b>VALVES OR TIMING-RELATED PARTS</b> 1. Worn camshaft. 2. Excessive valve clearance. 3. Worn timing gear. 4. Broken valve spring. 5. Excessive clearance between rocker arm and bushing. 6. Excessive clearance between idler gear bushing and spindle.	1. Replace camshaft. 2. Adjust valve clearance. 3. Replace timing gear. 4. Replace valve spring. 5. Replace bushing. 6. Replace bushing.
	<b>FUEL SYSTEM</b> 1. Poor quality and/or incorrect fuel. 2. Incorrect injection timing. Timing too advanced. 3. Fuel injector stuck open.	1. Use No. 2 diesel fuel. 2. Check and correct injection timing. 3. Locate and remove faulty injector. Rebuild or replace.
	<b>OTHER</b> 1. Coolant pump bearing worn or seized. 2. Improper drive-belt tension. 3. Malfunction of alternator bearing. 4. Exhaust gas leakage.	1. See <i>Coolant Pump</i> under <i>COOLING SYSTEM</i> . 2. Adjust. 3. See <i>Alternator Troubleshooting</i> under <i>DC ELECTRICAL SYSTEM</i> . 4. Repair.
<b>ROUGH OPERATION (HUNTING)</b>	<b>INJECTION PUMP</b> 1. Uneven injection. 2. Inadequate injection nozzle spray.	1. Adjust injection or replace parts. 2. Replace injection nozzle.
	<b>GOVERNING SYSTEM</b> 1. Governor lever malfunctioning. 2. Fatigued governor spring.	1. Check governor shaft and adjust. 2. Replace spring.

(continued)



# ENGINE TROUBLESHOOTING

PROBLEM	PROBABLE CAUSE	VERIFICATION/REMEDY
<b>SMOKY EXHAUST</b>	<b>WHITISH OR PURPLISH</b> 1. Engine is running cold. 2. Excessive engine oil. 3. Excessive rise of oil into combustion chamber. a. Poor piston contact. b. Piston ring or liner worn or seized. c. Excessive piston-to-cylinder clearance. d. Worn valve stem and valve guide. e. Low engine oil viscosity. f. Excessive oil pressure.  4. Injection timing is too late. 5. Insufficient compression.	1. Warm-up engine. 2. Correct oil level. 3. Check a. through f. a. Check. b. Clean or replace. c. Correct or replace. d. Replace valve stem and guide. e. Replace engine oil. f. Inspect the lubrication system. See <i>LUBRICATION SYSTEM</i> . 4. Adjust timing. 5. See <i>Low Compression</i> under <i>HARD STARTING</i> .
	<b>BLUE</b> 1. Incorrect grade of engine oil.  2. Crankcase is overfilled with engine oil (oil is blowing out through the exhaust).	1. Use the correct grade of oil; see <i>Oil Grade</i> under <i>SPECIFICATIONS</i> . 2. Decrease oil level.
	<b>BLACKISH OR DARK GRAYISH</b> 1. Poor compression. 2. Improper valve clearance. 3. Improper injection timing. 4. Improper fuel. 5. High back-pressure in exhaust. 6. Insufficient intake air. 7. Overload.	1. See <i>Low Compression</i> under <i>HARD STARTING</i> . 2. Adjust valve clearance. 3. Adjust injection timing. 4. Replace with proper fuel. 5. Check for restrictions in exhaust system. 6. Increase engine compartment air supply. 7. Reduce load.
	<b>BLACK, LARGE AMOUNT</b> 1. Clogged fuel filter. 2. Restricted air intake. 3. Engine overloaded.  4. Injection timing.  5. Fuel injectors not operating properly. 6. Improper grade of fuel.	1. Replace fuel filter and bleed system. 2. Remove air obstruction. 3. Check engine propeller size and engine performance no-load through fully loaded. 4. Check the injection pump timing and adjust as needed. 5. Check nozzle spray pressure setting. 6. Use specified grade of fuel.
<b>EXCESSIVE EXHAUST SMOKE</b>	1. Faulty injection timing. 2. Water in injection pump, fuel filter or fuel filter/water separator. 3. Faulty injection starting pressure. 4. Injection pump malfunctioning.	1. Adjust timing. 2. Drain fuel system.  3. Adjust starting pressure. 4. Replace injection pump.

(continued)

# ENGINE TROUBLESHOOTING

PROBLEM	PROBABLE CAUSE	VERIFICATION/REMEDY
<b>INTERMITTENT EXHAUST SOUND</b>	<ol style="list-style-type: none"> <li>1. Fuel filter clogged.</li> <li>2. Fuel line sucks air.</li> <li>3. Water mixed in fuel.</li> </ol>	<ol style="list-style-type: none"> <li>1. Clean or replace filter.</li> <li>2. Retighten fuel line joints or replace fuel line.</li> <li>3. Replace fuel.</li> </ol>
<b>EXCESSIVE FUEL CONSUMPTION</b>	<p><b>ENGINE PROBLEMS</b></p> <ol style="list-style-type: none"> <li>1. Noisy knocking.</li> <li>2. Smoky exhaust.</li> <li>3. Moving parts nearly seized or excessively worn.</li> <li>4. Poor compression.</li> <li>5. Improper valve timing.</li> <li>6. Improper valve clearance.</li> </ol>	<ol style="list-style-type: none"> <li>1. See <i>KNOCKING</i>.</li> <li>2. See <i>SMOKY EXHAUST</i>.</li> <li>3. Repair or replace.</li> <li>4. See <i>Low Compression</i> under <i>HARD STARTING</i>.</li> <li>5. Adjust timing.</li> <li>6. Adjust clearance.</li> </ol>
	<p><b>INSUFFICIENT INTAKE AIR</b></p> <ol style="list-style-type: none"> <li>1. Air intake obstructed.</li> </ol>	<ol style="list-style-type: none"> <li>1. Remove obstruction.</li> </ol>
	<p><b>FUEL INJECTION PROBLEMS</b></p> <ol style="list-style-type: none"> <li>1. Injection timing incorrect.</li> <li>2. Faulty injection starting pressure.</li> <li>3. Seized nozzle.</li> <li>4. Worn nozzle.</li> <li>5. Nozzle leaking.</li> <li>6. Injector not operating properly.</li> <li>7. Clogged fuel filter.</li> <li>8. High idling speed.</li> </ol>	<ol style="list-style-type: none"> <li>1. Adjust timing.</li> <li>2. Adjust starting pressure.</li> <li>3. Replace nozzle.</li> <li>4. Replace nozzle.</li> <li>5. Tighten nozzle or replace sealing gasket.</li> <li>6. Adjust nozzle spray pressure.</li> <li>7. Replace filter.</li> <li>8. Adjust idling speed.</li> </ol>
	<p><b>FUEL PROBLEMS</b></p> <ol style="list-style-type: none"> <li>1. Improper fuel.</li> <li>2. Fuel leaks.</li> </ol>	<ol style="list-style-type: none"> <li>1. Replace with proper fuel.</li> <li>2. Find fuel leaks.</li> </ol>
	<p><b>ENGINE OVERLOADED</b></p> <ol style="list-style-type: none"> <li>1. Propeller size.</li> </ol>	<ol style="list-style-type: none"> <li>1. Check propeller size and engine performance at rated rpm.</li> </ol>
<b>EXCESSIVE OIL CONSUMPTION</b>	<p><b>OIL LEAKAGE</b></p> <ol style="list-style-type: none"> <li>1. Defective oil seals.</li> <li>2. Broken gear case gasket.</li> <li>3. Loose gear case attaching bolts.</li> <li>4. Loose drain plug.</li> <li>5. Loose oil line connector.</li> <li>6. Broken rocker cover gasket.</li> <li>7. Loose rocker cover attaching bolts.</li> </ol>	<ol style="list-style-type: none"> <li>1. Replace oil seals.</li> <li>2. Replace gasket.</li> <li>3. Retighten bolts.</li> <li>4. Retighten plug.</li> <li>5. Retighten oil line connections.</li> <li>6. Replace gasket.</li> <li>7. Retighten attaching bolts.</li> </ol>

*(continued)*

# ENGINE TROUBLESHOOTING

PROBLEM	PROBABLE CAUSE	VERIFICATION/REMEDY
<b>EXCESSIVE OIL CONSUMPTION (cont'd)</b>	<b>OIL LEVEL RISING</b> 1. Incorrectly positioned piston ring gaps. 2. Displaced or twisted connecting rod. 3. Worn piston ring, or piston ring groove. 4. Oil ring worn or stuck 5. Worn piston or cylinder liner. 6. Worn crankshaft bearing and crankpin bearing.	1. Correct ring gap positions. 2. Replace connecting rod. 3. Replace ring or piston. 4. Replace oil ring. 5. Repair or replace. 6. Replace
	<b>OIL LEVEL FALLING</b> 1. Defective stem seal. 2. Worn valve and valve guide.	1. Replace stem seal. 2. Replace valve and valve guide.
<b>LOW OIL PRESSURE</b>	1. Worn main or connecting rod bearings. 2. Relief valve malfunction. 3. Diesel fuel is diluting the oil. 4. Oil strainer clogged. 5. Excessive oil clearance of crankshaft bearing. 6. Excessive oil clearance of crankpin bearing. 7. Excessive oil clearance of rocker arm bearing. 8. Oil passage clogged. 9. Improper grade of oil.	1. Replace bearings. 2. Overhaul oil pump. 3. Injection pump repair. 4. Clean oil strainer. 5. Replace crankshaft bearing. 6. Replace crankpin bearing. 7. Replace rocker arm bearing. 8. Clean oil passage. 9. Replace with specified grade of oil.
<b>HIGH OIL PRESSURE</b>	1. Relief valve defective. 2. Improper grade of oil.	1. Overhaul oil pump. 2. Replace with specified grade of oil.
<b>FUEL MIXED INTO LUBE OIL</b>	1. Injection pump plunger worn. 2. Deficient nozzle injection. 3. Injection pump malfunction.	1. Replace pump element or injection pump. 2. Repair or replace nozzle. 3. Replace injection pump.
<b>COOLANT MIXED INTO LUBE OIL</b>	1. Defective cylinder head gasket. 2. Defective cylinder head or cylinder block.	1. Replace cylinder head gasket. 2. Replace cylinder head or cylinder block.
<b>ENGINE OVERHEATS/ SHUTS DOWN</b>	1. V-belt slackening or slippery with oil. 2. Low oil level or poor oil quality. 3. Knocking. 4. Moving parts seized or damaged. 5. Lack of coolant. 6. Raw water not circulating.	1. Adjust, replace or clean belt. 2. Add or change oil. 3. See <i>KNOCKING</i> . 4. Replace. 5. Add coolant. 6. Check <b>a.</b> and <b>b.</b> <b>a.</b> Raw water pump failure. Check impeller; replace if necessary. <b>b.</b> Obstruction at raw water intake or raw water filter.

(continued)

# ENGINE TROUBLESHOOTING

PROBLEM	PROBABLE CAUSE	VERIFICATION/REMEDY
<b>ENGINE OVERHEATS/ SHUTS DOWN</b> (cont'd)	7. Coolant not circulating.	7. Check <b>a.</b> through <b>d.</b> <b>a.</b> Thermostat — remove and test in hot water. Replace thermostat. <b>b.</b> Loss of coolant — check hoses, hose clamps, drain plug, etc. for leaks. <b>c.</b> Broken or loose belt — tighten/replace. <b>d.</b> Air leak in system; run engine and open the pressure cap to bleed air. Add coolant as needed.

# SERVICE STANDARDS

These service standards specify the values at which the engine components will require adjustment, repair or replacement. It is important to observe these standards for your engine, and to take action when necessary to maintain a high level of safety, dependability and performance.

**NOTE:** Most of the service standards given in this section apply to all three UNIVERSAL Engine Models covered in this manual (M-25XPB, M-35B, M-40B). These engine models will only be listed where a particular service standard does not apply to all three models.

## ENGINE COMPONENTS

### Cylinder Head

DESCRIPTION	STANDARD VALUE	LIMIT
Cylinder Head Surface Flatness	—	0.0019 in. (0.05 mm)
Top Clearance	0.0217 – 0.0295 in. (0.55 – 0.75 mm)	—
Compression Pressure	412 – 469 psi (29.0 – 33.0 kgf/cm <sup>2</sup> ) (2.84 – 3.23 MPa)	327 psi (23 kgf/cm <sup>2</sup> ) (2.25 MPa)
Variance Among Cylinders	—	10% or less

### Valves

Valve Clearance (Cold)	0.0057 – 0.0072 in. (0.145 – 0.185 mm)	—
Valve Seal Width		
Intake	0.0835 in. (2.12 mm)	—
Exhaust	0.0835 in. (2.12 mm)	—
Valve Seal Angle		
Intake	60° (1.047 rad.)	—
Exhaust	45° (0.785 rad.)	—
Valve Face Angle		
Intake	60° (1.047 rad.)	—
Exhaust	45° (0.785 rad.)	—
Valve Recessing	0.0020 – 0.0060 in. (0.05 – 0.25 mm)	0.016 in. (0.4 mm)
Clearance between Valve Stem and Valve Guide	0.0014 – 0.0025 in. (0.035 – 0.065 mm)	0.0039 in. (0.1 mm)
Finishing Size		
Intake Valve Guide I.D.	0.2741 – 0.2764 in. (6.960 – 6.975 mm)	—
Exhaust Valve Guide I.D.	0.2760 – 0.2765 in. (7.010 – 7.025 mm)	—

### Valve Timing

DESCRIPTION	STANDARD VALUE	LIMIT
Intake Valve Open	14° (0.24 rad.) BTDC	—
Intake Valve Closed	30° (0.52 rad.) ABDC	—
Exhaust Valve Open	55° (0.96 rad.) BBDC	—
Exhaust Valve Closed	14° (0.24 rad.) ATDC	—

### Valve Spring

Free Length	1.457 – 1.476 in. (37.0 – 37.5 mm)	1.437 in. (36.5 mm)
Setting Load/Setting Length	26.4 lbs. / 1.22 in. (117.4 N / 31.0 mm) (11.97 kgf / 31.0 mm)	22.5 lbs. / 1.22 in. (100.0 N / 31.0 mm) (10.2 kgf / 31.0 mm)
Tilt	—	0.039 in. (1.0 mm)

### Rocker Arm

Clearance between Rocker Arm Shaft and Rocker Arm	0.0006 – 0.0018 in. (0.016 – 0.045 mm)	0.0039 in. (0.10 mm)
Rocker Arm Shaft O.D.	0.4714 – 0.4718 in. (11.973 – 11.984 mm)	—
Rocker Arm I.D.	0.4724 – 0.4731 in. (12.000 – 12.018 mm)	—

### Tappet

Clearance between Tappet and Guide	0.0008 – 0.0024 in. (0.020 – 0.062 mm)	0.0028 in. (0.07 mm)
Tappet O.D.	0.7858 – 0.7866 in. (19.959 – 19.980 mm)	—
Tappet Guide I.D.	0.7874 – 0.7882 in. (20.000 – 20.021 mm)	—

### Camshaft

Camshaft Side Clearance	0.0028 – 0.0087 in. (0.07 – 0.22 mm)	0.0118 in. (0.3 mm)
Camshaft Alignment	—	0.0004 in. (0.01 mm)
Cam Height		
Intake	1.1339 in. (28.80 mm)	1.1319 in. (28.75 mm)
Exhaust	1.1417 in. (29.00 mm)	1.1398 in. (28.95 mm)
Camshaft Oil Clearance	0.0020 – 0.0036 in. (0.050 – 0.091 mm)	0.0047 in. (0.12 mm)
Camshaft Journal O.D.	1.4147 – 1.3799 in. (35.934 – 35.050 mm)	—
Camshaft Bearing I.D.	1.4173 – 1.4183 in. (36.000 – 36.025 mm)	—

# SERVICE STANDARDS

## Timing Gear

DESCRIPTION	STANDARD VALUE	LIMIT
Timing Gear Backlash		
Crank Gear – Idler Gear No.1	0.0013 – 0.0045 in. (0.032 – 0.115 mm)	0.0059 in. (0.15 mm)
Idler Gear No.1– Cam Gear	0.0014 – 0.0045 in. (0.036 – 0.114 mm)	0.0059 in. (0.15 mm)
Idler Gear No.1– Injection Pump Gear	0.0013 – 0.0046 in. (0.034 – 0.116 mm)	0.0059 in. (0.15 mm)
Idler Gear No.1– Idler Gear No. 2	0.0013 – 0.0046 in. (0.033 – 0.117 mm)	0.0059 in. (0.15 mm)
Idler Gear No.2– Governor Gear	0.0012 – 0.0046 in. (0.030 – 0.117 mm)	0.0059 in. (0.15 mm)
Clearance between Idler Gear Shaft and Idler Gear Bushing		
Idler Gear No.1	0.0008 – 0.0021 in. (0.020 – 0.054 mm)	0.0039 in. (0.10 mm)
Idler Gear Bushing I.D.	1.0236 – 1.0244 in. (26.000 – 26.021 mm)	—
Idler Gear Shaft No.1 O.D.	1.0223 – 1.0228 in. (25.967 – 25.980 mm)	—
Idler Gear No.2	0.0008 – 0.0021 in. (0.020 – 0.054 mm)	0.0039 in. (0.10 mm)
Idler Gear Bushing I.D.	1.0236 – 1.0244 in. (26.000 – 26.021 mm)	—
Idler Gear Shaft No.2 O.D.	1.0223 – 1.0228 in. (25.967 – 25.980 mm)	—
Idler Gear Side Clearance		
Idler Gear No.1	0.0079 – 0.0200 in. (0.20 – 0.51 mm)	0.0315 in. (0.8 mm)
Idler Gear No.2	0.0079 – 0.0200 in. (0.20 – 0.51 mm)	0.0315 in. (0.08 mm)

## Piston & Piston Ring

Piston Pin Bore	0.8661 – 0.8687 in. (22.000 – 22.013 mm)	0.8673 in. (22.03 mm)
Clearance between Compression Ring No.2 and Ring Groove	0.0033 – 0.0044 in. (0.085 – 0.112 mm)	0.0079 in. (0.20 mm)
Clearance between Oil Ring and Ring Groove	0.0008 – 0.0021 in. (0.020 – 0.055 mm)	0.0059 in. (0.15 mm)
Ring Gap		
Compression Ring No.1	0.0118 – 0.0170 in. (0.30 – 0.45 mm.)	0.0492 in. (1.25 mm)
Compression Ring No.2	0.0118 – 0.0170 in. (0.30 – 0.45 mm.)	0.0492 in. (1.25 mm)
Oil Ring	0.0098 – 0.0157 in. (0.25 – 0.40 mm)	0.0492 in. (1.25 mm)

## Connecting Rod

DESCRIPTION	STANDARD VALUE	LIMIT
Connecting Rod Alignment	—	0.0020 in. (0.05 mm)
Clearance between Piston Pin and Small End Bushing	0.0006 – 0.0015 in. (0.014 – 0.038 mm)	0.0059 in. (0.15 mm)
Piston Pin O.D.	0.8662 – 0.8666 in. (22.002 – 22.011 mm)	—
Small End Bushing I.D.	0.8671 – 0.8677 in. (22.025 – 22.040 mm)	—

## Crankshaft

Crankshaft Alignment	—	0.0008 in. (0.02 mm)
Oil Clearance between Crankshaft and Crankshaft Bearing No.1	0.0013 – 0.0045 in. (0.034 – 0.114 mm)	0.0079 in. (0.20 mm)
Crankshaft O.D.	1.8872 – 1.8878 in. (47.934 – 47.950 mm)	—
Crankshaft Bearing No.1 I.D.	1.8891 – 1.8917 in. (47.984 – 48.084 mm)	—
Oil Clearance between Crankshaft and Crankshaft Bearing No.2	0.0013 – 0.0037 in. (0.034 – 0.095 mm)	0.0079 in. (0.20 mm)
Crankshaft O.D.	1.8872 – 1.8878 in. (47.934 – 47.950 mm)	—
Crankshaft Bearing No.2 I.D.	1.8891 – 1.8909 in. (47.984 – 48.029 mm)	—
Oil Clearance between Crankshaft and Crankshaft Bearing No.3	0.0013 – 0.0039 in. (0.034 – 0.098 mm)	0.0079 in. (0.20 mm)
Crankshaft O.D.	2.0441 – 2.0449 in. (51.921 – 51.940 mm)	—
Crankshaft Bearing No.3 I.D.	2.0462 – 2.0480 in. (51.974 – 52.019 mm)	—
Oil Clearance between Crank Pin and Crank Pin Bearing	0.0011 – 0.0036 in. (0.029 – 0.091 mm)	0.0079 in. (0.20 mm)
Crank Pin O.D.	1.5732 – 1.5738 in. (39.959 – 39.975 mm)	—
Crank Pin Bearing I.D.	1.5750 – 1.5768 in. (40.004 – 40.050 mm)	—
Crankshaft Side Clearance	0.0059 – 0.0122 in. (0.15 – 0.31 mm)	0.0197 in. (0.50 mm)

## Cylinder Liner

Cylinder Liner I.D.		
M-25XPB	2.9921 – 2.9929 in. (76.000 – 76.019 mm)	+0.0059 in. (+0.15 mm)
M-35B		
M-40B	3.0709 – 3.0716 in. (78.000 – 78.019 mm)	+0.0059 in. (+0.15 mm)
Oversized Cylinder Liner I.D.	+0.0197 in. (+0.5 mm)	+0.0059 in. (+0.15 mm)

# SERVICE STANDARDS

## LUBRICATION SYSTEM

### Oil Pump

DESCRIPTION	STANDARD VALUE	LIMIT
Engine Oil Pressure At Idle Speed	7 psi (0.5 kgf/cm <sup>2</sup> ) (49 kPa)	—
At Rated Speed	28.0 – 64.0 psi (2.0 – 4.5 kgf/cm <sup>2</sup> ) (196.0 – 441.0 kPa)	21.3 psi (1.5 kgf/cm <sup>2</sup> ) (147.1 kPa)
Clearance between Inner Rotor and Outer Rotor	0.0024 – 0.0071 in. (0.06 – 0.18 mm)	—
Clearance between Outer Rotor and Pump Body	0.0039 – 0.0071 in. (0.100 – 0.180 mm)	—
End Clearance between Inner Rotor and Cover	0.0098 – 0.0295 in. (0.025 – 0.75 mm)	—

## COOLING SYSTEM

### Thermostat

Thermostat's Valve Opening Temperature	157.1 – 162.5°F (69.5 – 72.5°C)	—
Temperature at which Thermostat Completely Opens	185°F (85°C)	—

## FUEL SYSTEM

### Injection Pump

Injection Timing (Spill Timing) 3000 rpm	18 – 20° BTDC (0.31 – 0.35 rad.)	—
Pump Element Fuel Tightness	—	2133 psi 150 kgf/cm <sup>2</sup> 14.7 MPa
Delivery Valve Fuel Tightness	10 seconds or more 2133 → 1990 psi (150 → 140 kgf/cm <sup>2</sup> ) (14.7 → 13.7 MPa)	5 seconds 2133 → 1990 psi (150 → 140 kgf/cm <sup>2</sup> ) (14.7 – 13.7 MPa)

### Injection Nozzle

Fuel Injection Pressure	1991 – 2133 psi (140 – 150 kgf/cm <sup>2</sup> ) (13.73 – 14.71 MPa)	—
Nozzle Valve Seat Tightness	When the pressure is 1849 psi (130 kgf/cm <sup>2</sup> ) (12.75 MPa), the valve seat must not leak fuel.	—

## ELECTRICAL SYSTEM

### Starter

DESCRIPTION	STANDARD VALUE	LIMIT
Commutator O.D.	1.1811 in. (30.0 mm)	1.1417 in. (29.0 mm)
Mica Undercut	0.0197 – 0.0315 in. (0.5 – 0.8 mm)	0.079 in. (0.2 mm)
Brush Length	0.5118 in. (13.0 mm)	0.3346 in. (8.5 mm)

### Alternator

No-load Voltage	13.7 – 14.7 V at 1500 – 2000 rpm
Stator Resistance	4.1 – 4.7 Ω at 70 – 80°F (21 – 27°C)
Brush Length (minimum)	0.25 in. (6 mm)

### Glow Plug

Glow Plug Resistance	Approx. 0.9 – 1.2 Ω	—
----------------------	---------------------	---

# ENGINE DESCRIPTION

## CYLINDER BLOCK

The engine has a high durability tunnel-type cylinder block in which the crank bearing component is a constructed body.

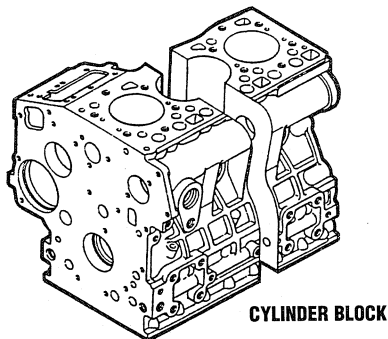

## CYLINDER HEAD

The cross-flow type intake and exhaust ports in this engine have their openings at both sides of the cylinder head. Because the overlaps of the intake and exhaust ports are smaller than in the ports of other types of engines which have their openings on one side, the intake air is protected from being heated and expanded by the heated exhaust air. The cool, high-density intake air has high volume efficiency and increases the power of the engine. Distortion of the cylinder head by heated exhaust gas is reduced because the intake ports are arranged alternately.

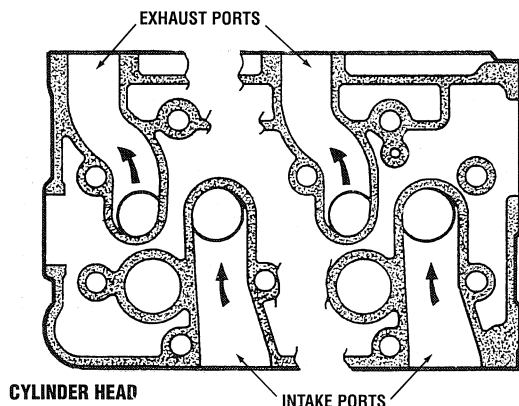

Installed into the precombustion chamber are a throttle type fuel injector and a rapid-heating sheathed-type glow plug. The glow plugs assure easier engine starts, even at 5° F (-15° C).

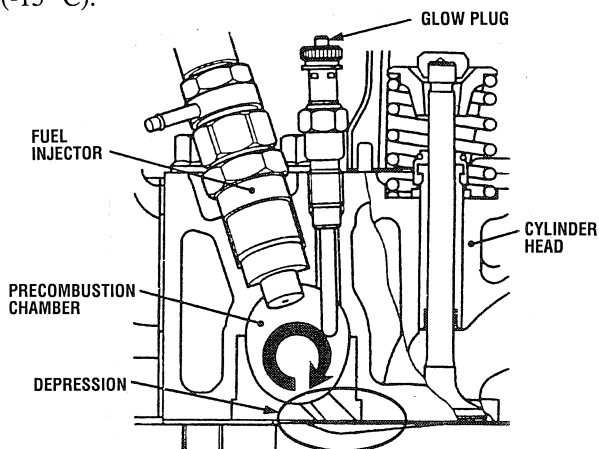

In the precombustion chamber, the intake air is whirled and mixed efficiently with the fuel, assuring proper combustion and reducing fuel consumption. The shape of the throat in the air inlet to the combustion chamber produces, under compression, an ideal mixture of air and fuel.

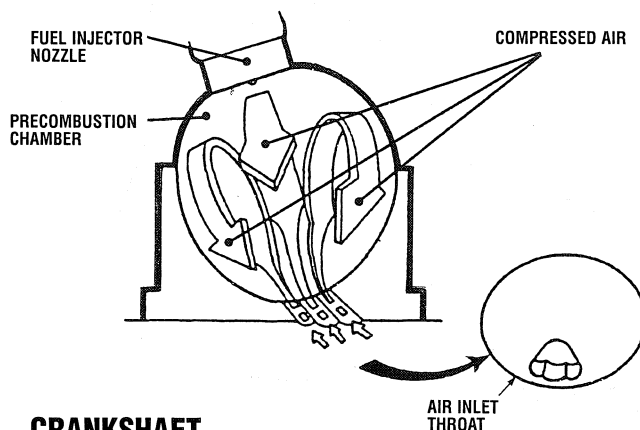

## CRANKSHAFT

The crankshaft with the connecting rod converts the reciprocating motion of the piston into a rotating motion. The crankshaft is made of tough special alloy steel, and the journals, pins and oil seal sliding portions are induction-hardened for higher wear resistance. The front journal is supported by a solid type bearing, the intermediate journal by a split type bearing and the rear journal by a split type bearing with thrust bearings. The crankshaft has an oil gallery, through which engine oil is fed to the crankpin to lubricate it.

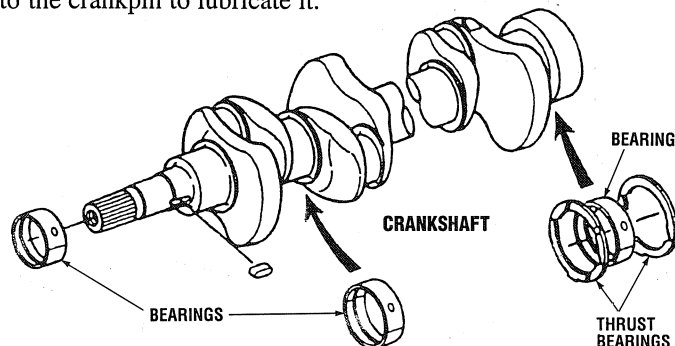

## PISTON AND PISTON RINGS

The piston has a slightly oval shape when cold due to thermal expansion and a concave head. Three rings are installed in grooves in the piston.

The top ring is a keystone type, which can stand heavy loads, and the barrel-shaped facing on this ring fits well to the cylinder wall.

The second ring is an undercut type, which effectively prevents the oil from being carried up.

The oil ring has chamfered contact faces and an expander ring, which increases the pressure of the oil ring against the cylinder wall.



# ENGINE DESCRIPTION

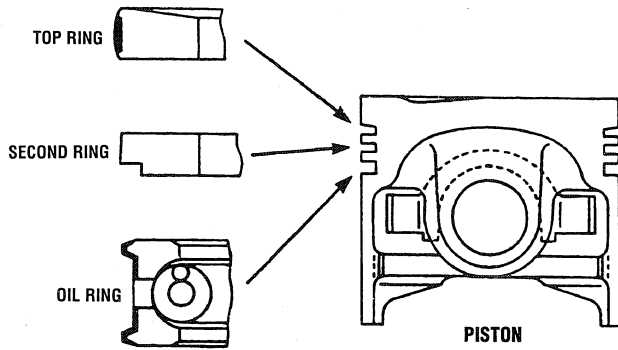

Several grooves are cut into the piston's crown to swirl the fuel/air mixture for complete combustion and to allow a smooth ejection of the exhaust gas.

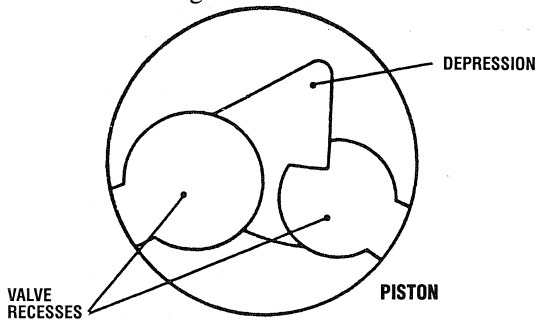

## CONNECTING ROD

The connecting rod connects the piston to the crankshaft. The big end of the connecting rod has a split type crankpin bearing and the small end has a solid type bushing.

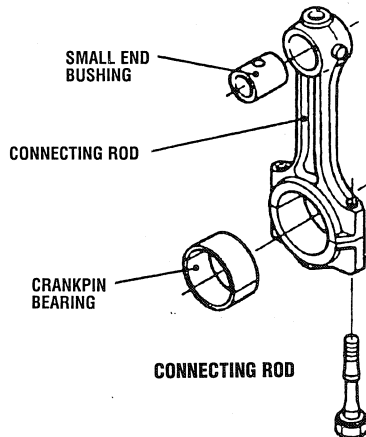

## ROCKER ARM

The rocker arm assembly includes the rocker arms, rocker arm brackets and rocker arm shaft. This assembly converts the reciprocating movement of the push rods to an open/close movement of the intake and exhaust valves.

Lubricating oil is force-fed through the bracket to the rocker arm shaft, which by its reciprocating motion, distributes lubricating oil throughout the entire rocker arm assembly.

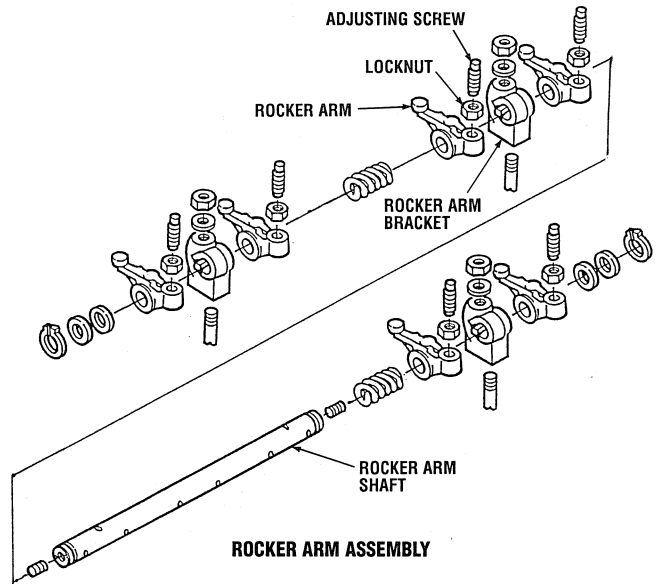

## CAMSHAFT

The camshaft is made of special cast iron, and the journal and cam sections are hardened to resist wear. The journal sections are force-lubricated.

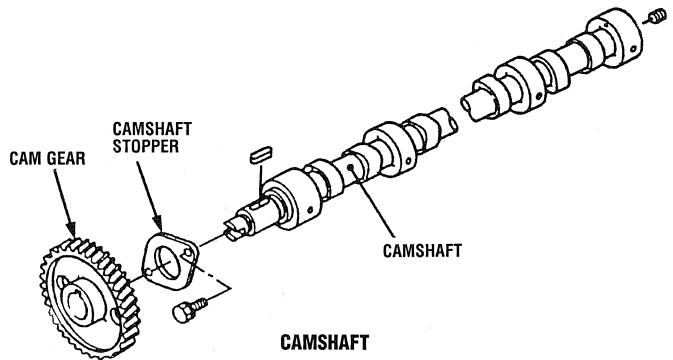

## FUEL CAMSHAFT

The fuel camshaft controls the reciprocating movement of the injection pump. The fuel camshaft is made of carbon steel and the cam sections are quenched and tempered to provide greater wear resistance.

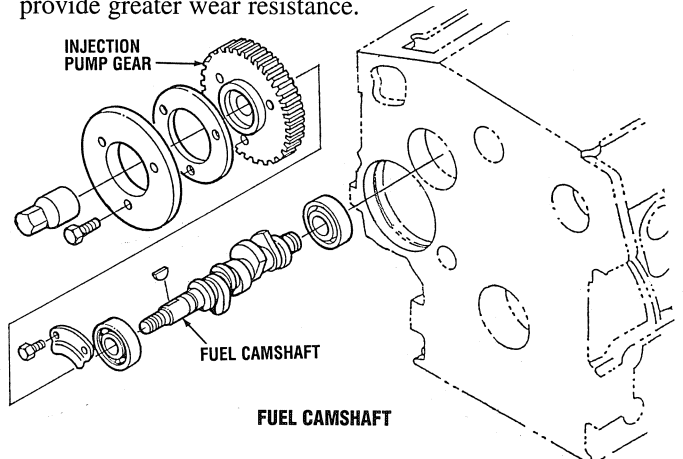

# ENGINE DESCRIPTION

## FLYWHEEL

The flywheel stores the rotating force of the combustion stroke as inertial energy, reduces crankshaft rotating speed fluctuation and maintains smooth rotating conditions. The flywheel's periphery is inscribed with marks showing the fuel injection timing angle lines and the top dead center mark **TC**. It has gear teeth around its outer rim that mesh with the starter's drive pinion

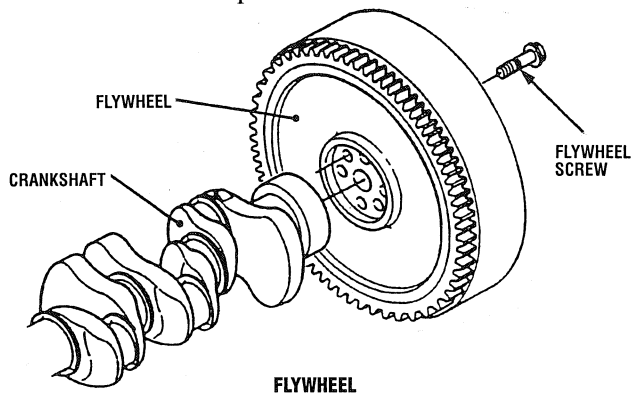

# ENGINE DISASSEMBLY & REASSEMBLY

Before disassembling your engine, read the following *GENERAL DISASSEMBLY PROCEDURES* and *GENERAL REASSEMBLY PROCEDURES*. They will provide important information to ensure the proper servicing of your engine.

The *EXTERNAL COMPONENTS DISASSEMBLY/REASSEMBLY* section gives the order of removal of the engine's external components (alternator, heat exchanger, air intake silencer, etc.). These components are reinstalled in the reverse of their order of disassembly.

Specific disassembly/reassembly information is provided for the main engine parts (bearings, crankshaft, pistons, etc.) in individual sections.

## GENERAL DISASSEMBLY PROCEDURES

**NOTE:** Before disassembly and cleaning, carefully check for defects which cannot be found after disassembly and cleaning.

- All disassembled parts should be carefully arranged in the order of reassembly. Mark or label the parts as needed to insure proper mating and reassembly in the proper directions and positions.
- If the disassembly procedure is complex requiring many parts to be disassembled, the parts should be disassembled in a way that will allow them to be efficiently reassembled without any change in the engine's external appearance or its performance.
- Do not remove or disassemble parts that require no disassembly.
- Carefully inspect each part after removal for damage, deformation, and other problems.
- Carefully check gaskets packings and oil seals, even if checking is not specified. Replace with new ones, if defective.
- Be careful not to damage the disassembled parts. Keep the parts clean.
- Use the proper tools. Apply oil when necessary. Take special care to keep the fuel system parts free from the intrusion of dust and dirt.

## GENERAL REASSEMBLY PROCEDURES

- Clean or wash the parts to be reassembled. Apply lubricating oil when specified or as needed to the surfaces of moving parts during reassembly. Heavily oil sliding, turning, rotating and reciprocating parts; lightly oil head bolts and other fasteners except those that penetrate into the water jacket. These fasteners should be sealed with *Permatex No. 2* or a high-tack equivalent. Make sure that moving parts, after assembly onto the engine, are not subject to binding or excessive tension.
- Carefully check gaskets, packings and oil seals, even if checking is not specified. Use new gaskets, lockwashers and O-rings.
- Be careful not to mix bolts and nuts. Both metric and S.A.E. bolts are used on various engine assemblies.

- Replace plain bearings if they are peeling, burned or otherwise damaged.
- Reassemble parts (e.g. pistons, piston rings, bearings, bearing caps) in their proper order, positions and directions relative to the engine block. Avoid reversed orientation – note that the cylinder head gasket, head bolt washers and thermostat are asymmetrical. Any mating marks that were drawn or scribed during disassembly should be positioned correctly for reassembly. Position gaskets carefully, especially the head gasket, so they will not be damaged during assembly.
- Inspect all critical clearances, end plays, oil clearances, and bends. Refer to the *SERVICE STANDARDS* section.
- Use liquid sealants when specified or needed on nuts, bolts and gaskets. Use *Permatex No. 2* or equivalent. Don't use tape sealants. Refer to *SEALANTS & LUBRICANTS* in this manual.
- Tighten the bolts and nuts on the important parts of the engine to the specified torques using a reliable torque wrench. Tighten fasteners in the specified torque sequences, and in three steps: 1/2, 2/3, and 1/1 torque. Exceptions are torque-to-yield head bolts and rocker arm shaft fasteners. The former are torqued as indicated. The latter – rocker shaft fasteners – should be brought down in very small increments, working from the center bolts out. Where a tightening torque is not specified, tighten evenly to an ordinary torque.
- After completion of reassembly, recheck for any abnormalities. Then fill the engine cooling system with pre-mixed coolant (50/50 good quality antifreeze and distilled water). Fill the engine oil sump to the mark on the dipstick with lube oil (A.P.I. spec. CF or CG-4).

Test run the engine under load prior to reinstalling. At this time readjust the valve clearances on the hot engine.

Allow the engine to cool to room temperature and retorque the cylinder head bolts and re-check the valve clearances (see *ENGINE ADJUSTMENTS*).

## TRANSMISSION

1. Unplug the instrument panel wiring harness.
2. Drain the transmission fluid.
3. Unbolt the transmission from the engine.

**NOTE:** For transmission service and maintenance, refer to your transmission owner's manual. To rebuild a transmission, contact your WESTERBEKE dealer or a qualified marine transmission service facility.

If the transmission is not being rebuilt, it should be visually inspected. Inspect and lubricate the gear shift linkage and the propeller shaft coupling. Clean and repaint the transmission and change the transmission fluid. Refer to the *TRANSMISSIONS* section in this manual.

# ENGINE DISASSEMBLY & REASSEMBLY

## EXTERNAL COMPONENTS DISASSEMBLY/REASSEMBLY

**NOTE:** After servicing the engine, reinstall the external components in the reverse of their order of removal.

With the transmission separated from the engine, begin the following step-by-step disassembly procedure.

1. Clean the exterior of the engine of any deposits of dirt and oil.
2. Mount the engine on a suitable engine stand for disassembly.
3. Drain the coolant from the engine and engine hoses, and from the heat exchanger. Drain the fuel, and drain or pump out the engine oil.
4. Remove the engine wiring harness in its entirety. Label the terminal connections to insure proper reattachment.

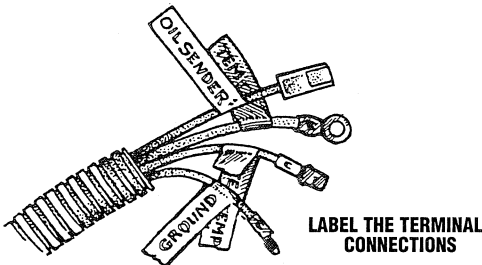

### When Reassembling:

Check all AC and DC wiring connections by referring to the *UNIVERSAL* wiring diagrams and schematics.

5. Remove the engine heat exchanger. If possible, leave one end of each hose connection attached to the heat exchanger. The heat exchanger should be serviced when the engine is overhauled (see *HEAT EXCHANGER* under *COOLING SYSTEM* for inspection and servicing information).

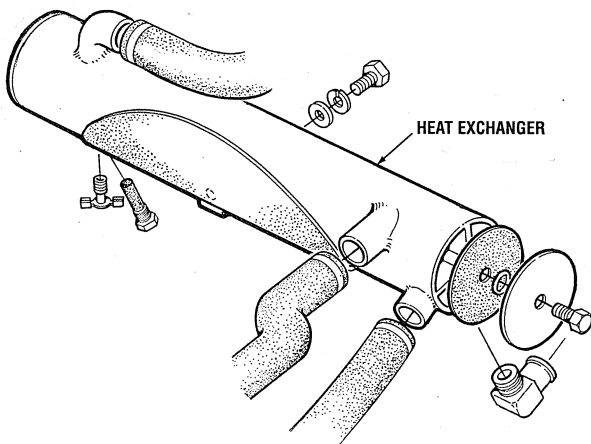

6. Remove the starter motor.
7. Remove the engine bellhousing.
8. Remove the transmission damper plate.
9. Remove the flywheel and flywheel washer.
10. Remove the engine back plate.

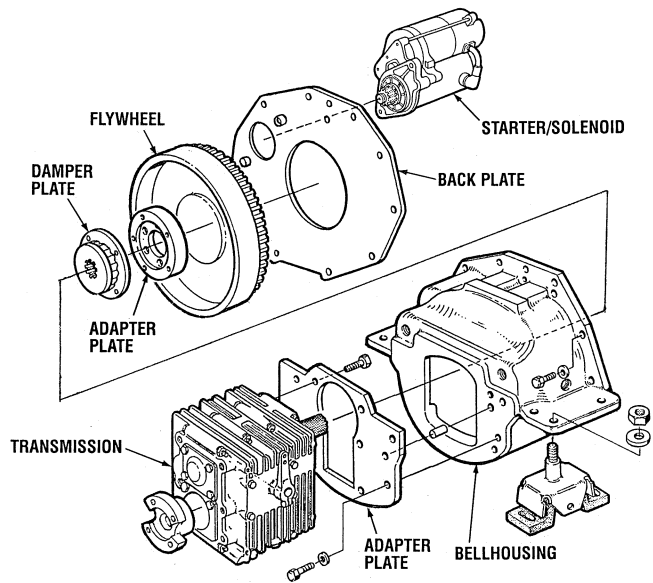

11. Remove the exhaust manifold.

### When Reassembling:

Retighten the exhaust manifold using the same torque after idling for 20 minutes.

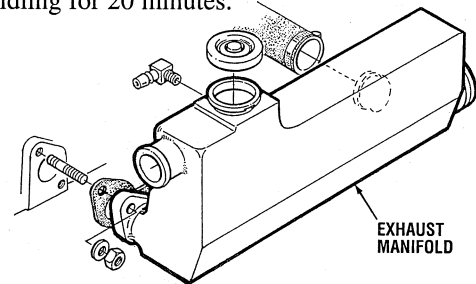

12. Remove the drive belt, alternator and alternator adjusting strap.

See *ALTERNATOR TROUBLESHOOTING* for testing information.

### When Reassembling:

**CAUTION:** Connect the alternator properly. Should the polarity be reversed, a powerful current would flow from the battery into the alternator, damaging the diodes and wiring harness.

- a. Install the alternator cap screw through the alternator leg (underside) and spacer into the alternator bracket.
- b. Swing the alternator into position on the adjusting strap and fasten. Lightly tighten.
- c. Install the drive belt and adjust the belt tension.
- d. Tighten both bolts and recheck the belt tension.

**NOTE:** Make certain the belts are perfectly aligned with the alternator and engine pulleys. If not, insert or remove spacers as needed, to align the alternator.

# ENGINE DISASSEMBLY & REASSEMBLY

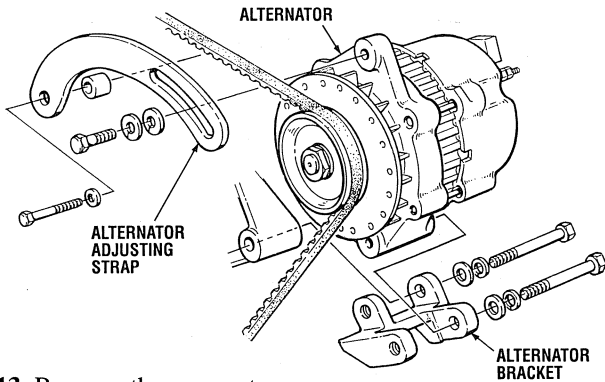

13. Remove the raw water pump.
14. Remove all the high pressure injector lines from the injection pump to the injectors. Leave the upper line clamps in place.  
**NOTE:** Cap the ends of the lines, and the connections at the injection pump and at the injectors, to prevent entry of foreign material.
15. Remove the oil level dipstick.
16. Remove the oil filter/oil cooler assembly.
17. Remove the fuel line to the injection pump. (Note the arrangement of the sealing washers on the banjo bolts at the fuel filter and the injection pump.)
18. Remove the fuel return lines from the top of the injectors and from the fuel injection pump. (Note the washer arrangement on the fuel return line banjo bolts. Cap all openings on the fuel return line, injectors and injection pump.)
19. Remove the engine-mounted fuel filter and fuel filter bracket.
20. Remove the thermostat housing, gasket, and the thermostat. Leave the temperature sender in place.

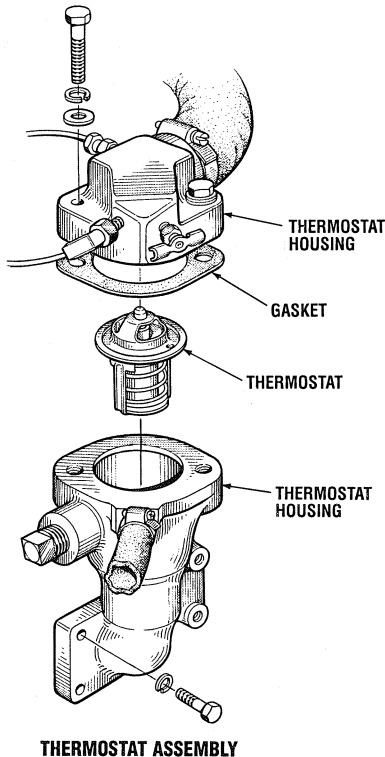

21. Remove the air intake silencer.
22. Remove the front and rear lifting eyes.
23. Remove the intake manifold.
24. Remove the alternator bracket.
25. Remove the crankcase breather hose.

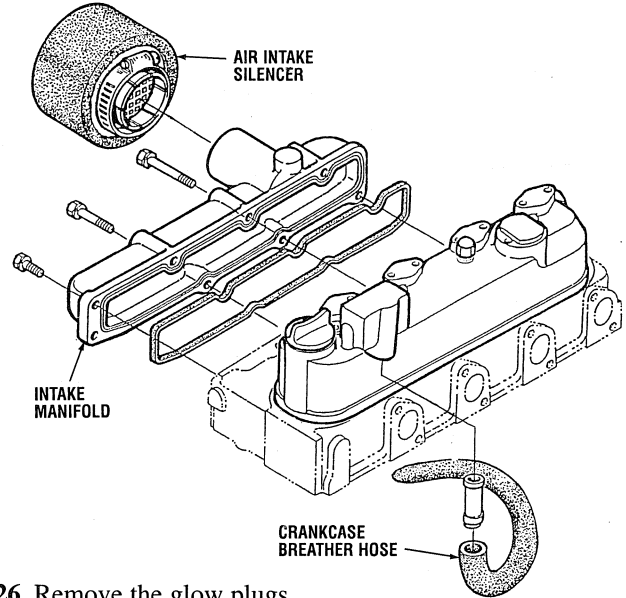

26. Remove the glow plugs.

## CYLINDER HEAD AND VALVES

### Nozzle Holder Assembly

1. Loosen the screws on the fuel injection line clamps.
2. Remove the injection lines.
3. Remove the fuel overflow lines.
4. Loosen the injector and unscrew it from the cylinder head.
5. Remove the copper washers on the seats.

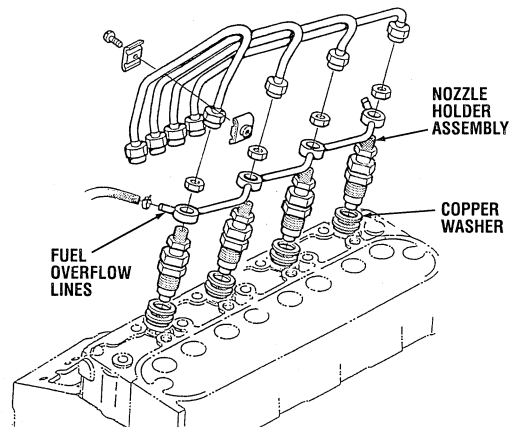

6. Remove the nozzle heat seal.

**NOTE:** Use a Phillips screwdriver that has a diameter larger than the heat seal hole (0.25 in (6 mm)).

- a. Insert the screwdriver lightly into the heat seal hole.

# ENGINE DISASSEMBLY & REASSEMBLY

- b. Turn the screwdriver three or four times in each direction. While turning the screwdriver, slowly pull the heat seal out together with the injection nozzle copper washer.
- c. If the heat seal drops, repeat the above procedure. The heat seal and injection nozzle copper washer must be changed when the injection nozzle is removed for cleaning or for service.

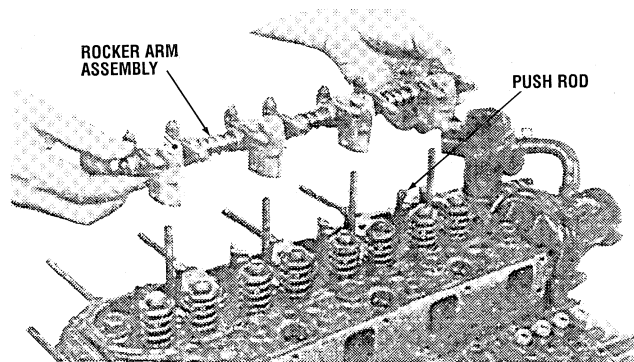
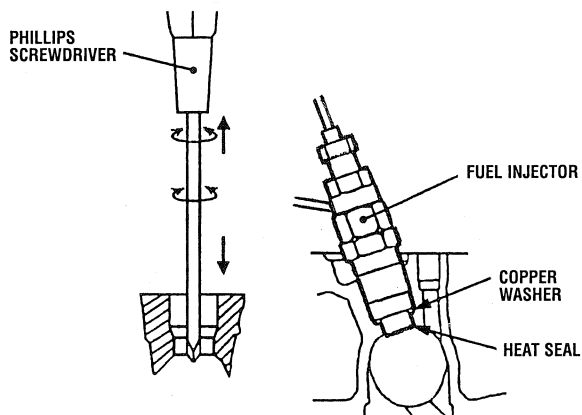

## Cylinder Head Cover

1. Remove the cylinder head cover cap nuts.
2. Remove the cylinder head cover.

### When Reassembling:

1. Check the cylinder head cover gasket; if it is defective, replace it.

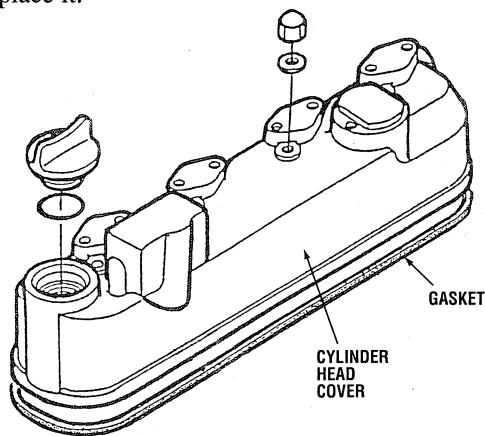

## Rocker Arm and Push Rod

1. Remove the rocker arm bracket mounting nuts.
2. Detach the rocker arm as an assembly.
3. Remove the push rods.

### When Reassembling:

1. When installing the push rods onto the tappets, make sure their ends are properly engaged with the grooves.

**NOTE:** After reassembling the rocker arm assembly, be sure to adjust the valve clearances.

## Cylinder Head

1. Remove the air breather hose.
2. Remove the cylinder head screws in a descending sequence (see illustration): Model M-25XPB, from 14 to 1; Models M-35B and M-40B, from 18 to 1. Then remove the cylinder head.
3. Remove the cylinder head gasket and O-ring.

### When Reassembling:

1. Replace the head gasket with a new one.
2. Install the cylinder head, using care not to damage the O-ring.
3. After applying engine oil, tighten the cylinder head screws gradually in an ascending sequence (see illustration): Model M-25XPB, from 1 to 14; Models M-35B and M-40B, from 1 to 18.
4. Retighten the cylinder head screws after running the engine for 30 minutes.

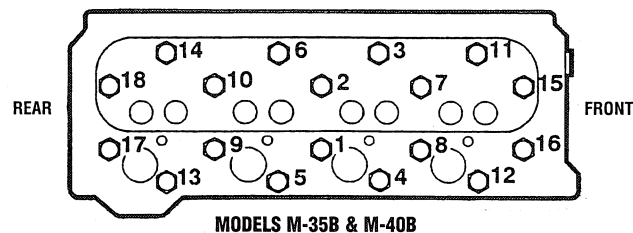
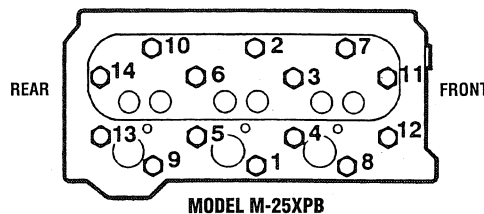

## Tappets

1. Remove the tappets from the crankcase.

**NOTE:** Mark the cylinder numbers on the tappets to prevent interchanging.

### When Reassembling:

1. Before installing the tappets, apply engine oil thinly around them.

# ENGINE DISASSEMBLY & REASSEMBLY

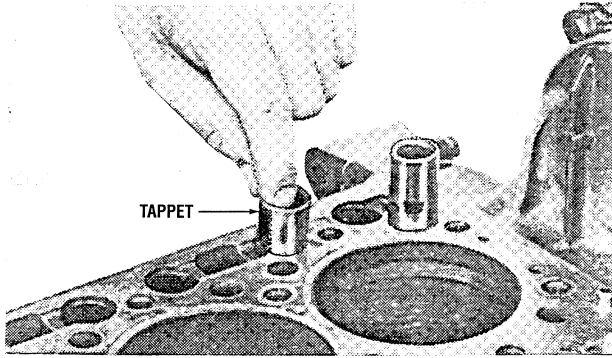

TAPPET

TAPPETS

## Valves

1. Remove the valve cap.
2. Remove the valve spring collet with a valve lifter.
3. Remove the valve spring retainer, valve spring and valve.

### When Reassembling:

1. Wash the valve stem and valve guide hole, and apply sufficient engine oil.
2. After installing the valve spring collet, lightly tap the valve stem to assure a proper fit.

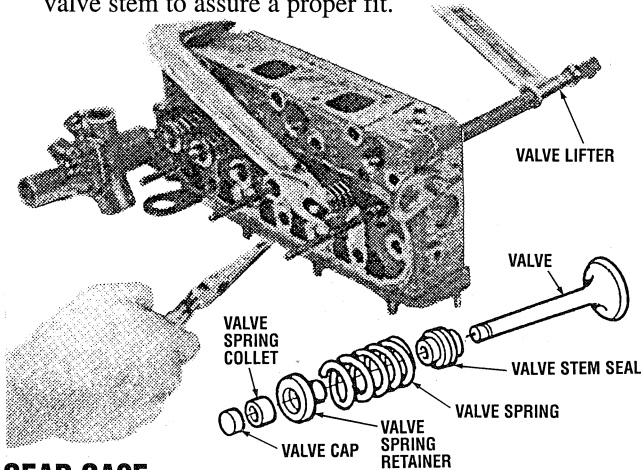

VALVE LIFTER

VALVE

VALVE SPRING COLLET

VALVE STEM SEAL

VALVE SPRING

VALVE CAP

VALVE SPRING RETAINER

## GEAR CASE

### Coolant Pump

1. Remove the coolant pump flange.

### When Reassembling:

1. Apply a liquid gasket (*Three Bond 1215* or equivalent) to both sides of the water pump flange gasket.

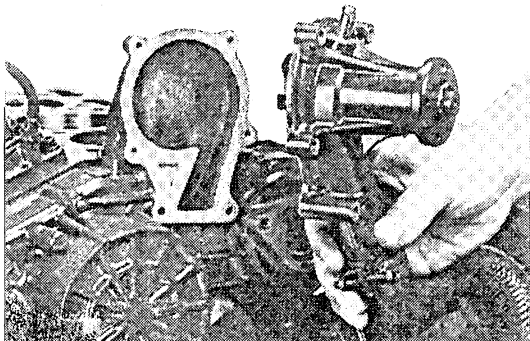

COOLANT PUMP

## Gear Case

1. Remove the gear case.

### When Reassembling:

1. Apply a liquid gasket (*Three Bond 1215* or equivalent) to both sides of the gear case gasket.
2. Apply a thin coat of grease to the oil seal and install it, ensuring the lip does not come off.

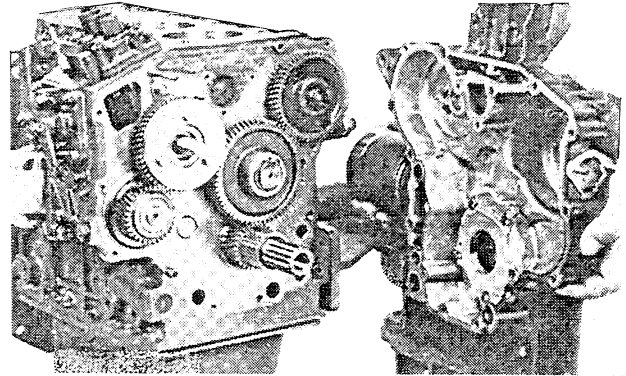

GEAR CASE

Length of the gear case mounting bolts (see illustration):

- |          |          |
|----------|----------|
| A: 45 mm | E: 68 mm |
| B: 50 mm | F: 80 mm |
| C: 55 mm | G: Nut   |
| D: 59 mm |          |

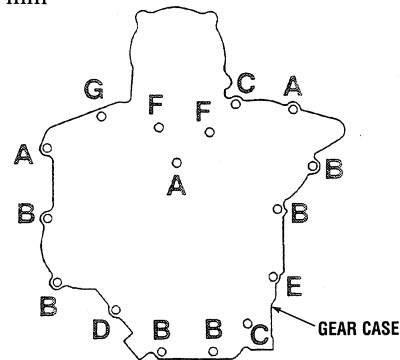

## Engine Stop Solenoid (optional) and Speed Control Plate

1. Remove the engine stop solenoid.
2. Remove the speed control plate with the governor springs.

### When Reassembling:

1. Apply a liquid gasket (*Three Bond 1215* or equivalent) to both sides of the solenoid cover gasket and control plate gasket.
2. Be careful not to drop the governor springs into the crankcase.

# ENGINE DISASSEMBLY & REASSEMBLY

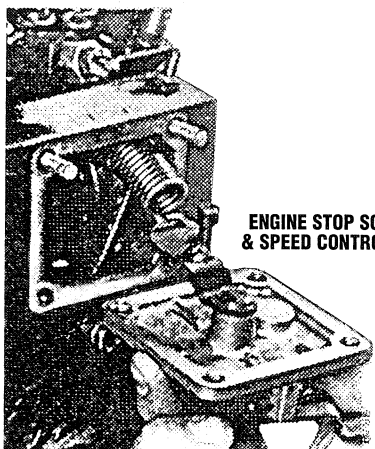

ENGINE STOP SOLENOID  
& SPEED CONTROL PLATE

## Injection Pump

1. Align the control rack pin with the notch on the crankcase and remove the injection pump.
2. Remove the injection pump shims.

**NOTE:** The fuel injection pump is a very important component of the diesel engine, requiring the utmost care in handling. It has been thoroughly bench-tested, and the owner/operator is cautioned not to attempt to service it. If the fuel injection pump requires servicing, remove it and take it to an authorized fuel injection pump service facility. Do not attempt to disassemble and repair it. If the pump is defective, UNIVERSAL recommends that you replace the entire pump.

The only adjustments the servicing mechanic should make to the fuel injection pump are the adjustments for idle speed (see *IDLE SPEED ADJUSTMENT* under *ENGINE ADJUSTMENTS*), and injection timing (see *INJECTION TIMING ADJUSTMENT*), below.

### When Reassembling:

1. When installing the injection pump, insert the control rack pin firmly into the groove of the fork lever and thrust lever.
2. Install the shims as follows:

#### Engine Serial Numbers up to 489290:

1. Insert the same number of shims as used before, between the crankcase and the injection pump.
2. The addition or subtraction of a shim 0.0059 in. (0.15 mm) delays or advances the injection timing by approx. 1.5° (0.026 rad.).
3. Apply a liquid-type gasket (*HIGH TACK* or equivalent) to both sides of the injection pump shim before reassembling.

### Engine Serial Numbers 489291 and up:

1. Apply sealant to both sides of the soft metal gasket shim. Liquid gasket is not required.
2. The addition or subtraction of a shim (0.0020 in. (0.05 mm)) delays or advances the injection timing by approx. 0.5° (0.0087 rad.).
3. In disassembling and replacing shims, be sure to use the same number of new gasket shims having the same thickness.

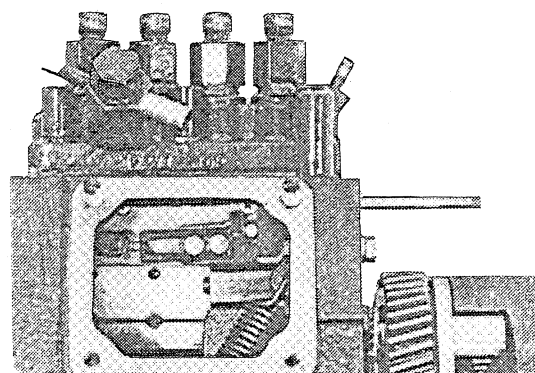
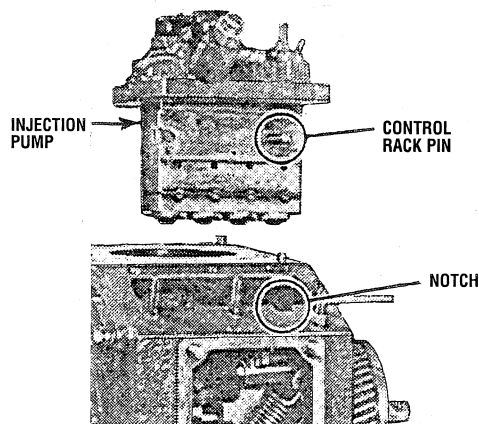

## Fuel Camshaft

1. Remove the fuel camshaft stopper.
2. Pull out the fuel camshaft and injection pump gear.

### When Reassembling:

1. Apply a thin coat of engine oil to the fuel camshaft before installing.

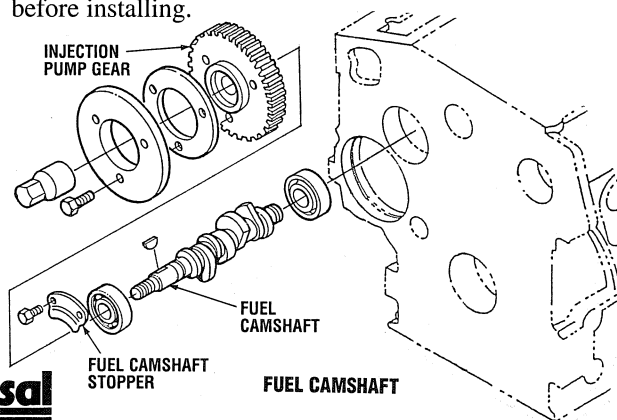



# ENGINE DISASSEMBLY & REASSEMBLY

## Governor Shaft

1. Remove the snap ring from the governor shaft.

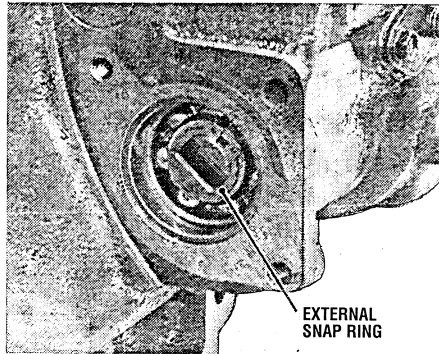

2. Remove the governor shaft.

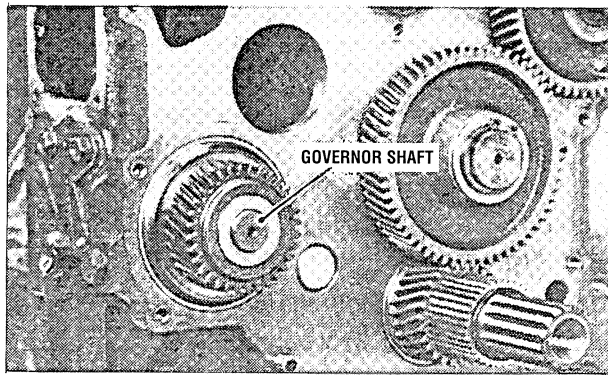

### When Reassembling:

1. Make sure the external snap ring for the governor shaft is installed.
2. Check the governor shaft for smooth rotation.

**NOTE:** When replacing the ball bearing for the governor shaft, securely fit the ball bearing to the crankcase, apply an adhesive (*Three Bond 1324B* or equivalent) to the set screw, and insert the set screw until its tapered part contacts the side of the ball bearing.

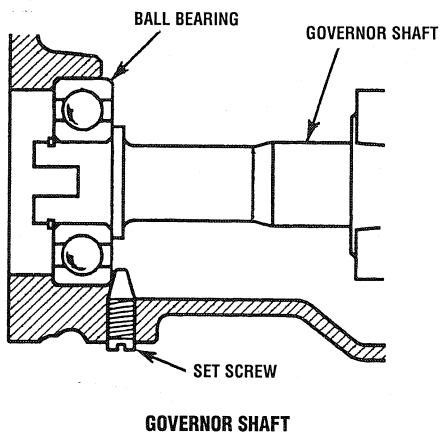

## Fork Lever

1. Remove the start spring.
2. Remove the fork lever shaft cover.
3. Remove the fork lever shaft.
4. Remove the spacer, bearing, and fork levers 1 and 2.

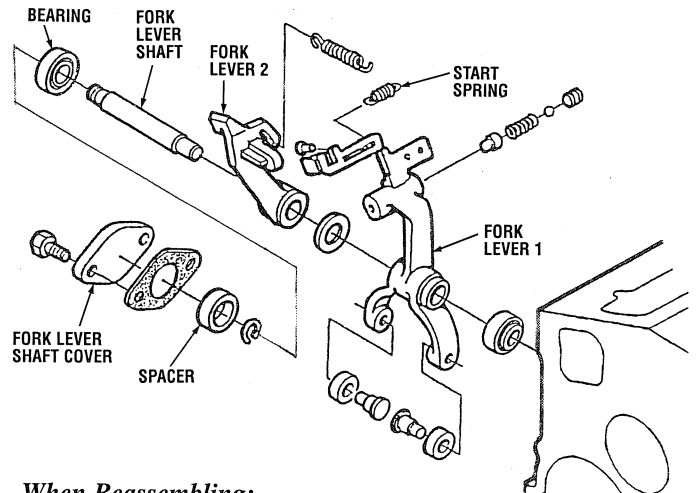
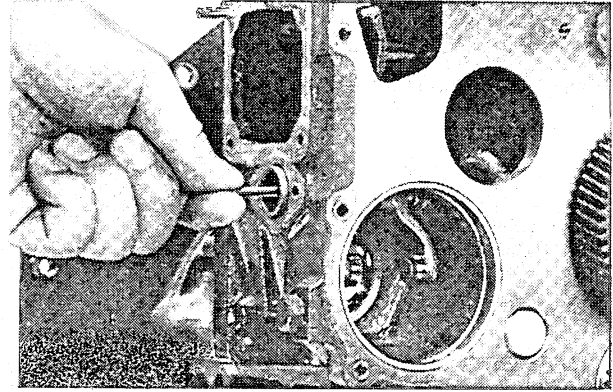

### When Reassembling:

1. Apply a liquid gasket (*Three Bond 1215* or equivalent) to both sides of the fork lever shaft cover.
2. Assemble the fork lever shaft cover with the mark "UP" on it facing upward.
3. Make sure the start spring is assembled.

**NOTE:** Assemble fork lever 2 to the right side of the fuel limit bolts as shown in the illustration.

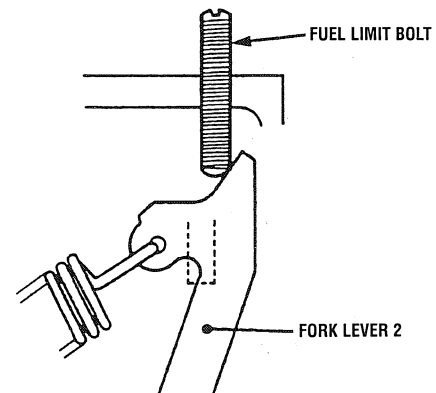

# ENGINE DISASSEMBLY & REASSEMBLY

## Camshaft Gear and Idler Gear #1

1. Remove the snap ring.
2. Remove the idler gear.
3. Remove the camshaft stopper mounting bolt.
4. Remove the camshaft.

**NOTE:** When installing the idler gear, be sure to align the alignment marks on the gears. Make sure to assemble the external snap ring and stopper.

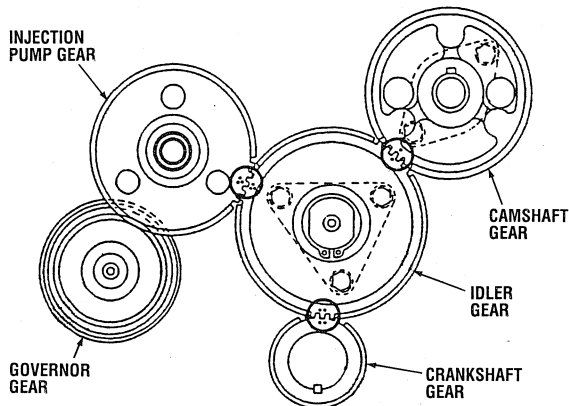
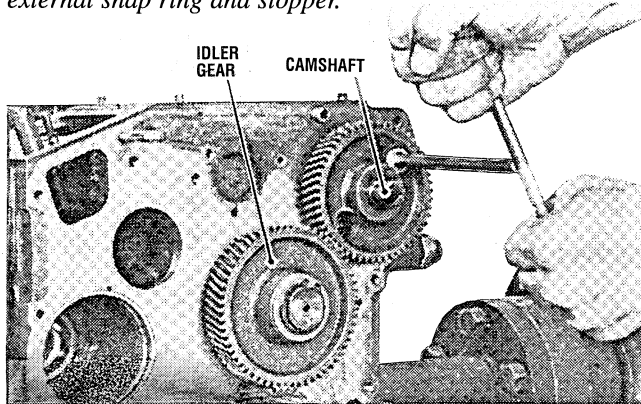

## PISTON AND CONNECTING ROD

### Oil Pan and Oil Pan Filter

1. Remove the oil pan mounting screws.
2. Remove the oil pan by lightly tapping the rim of the pan with a wooden hammer.
3. Remove the oil pan filter.

#### When Reassembling:

1. Apply a liquid gasket (*Three Bond 1215* or equivalent) to both sides of the oil pan gasket.
2. To avoid uneven tightening, tighten the mounting screws in a diagonal pattern from the center.
3. Clean the oil pan filter and install it. Take care not to damage the O-ring.

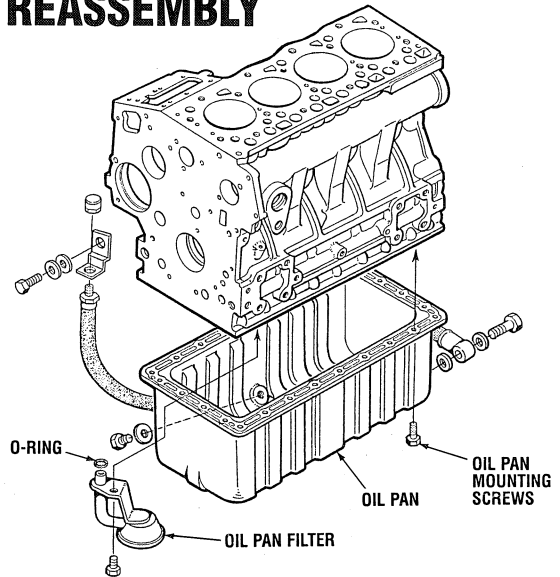

## Connecting Rod Cap

1. Remove the connecting rod screws from the connecting rod caps.
2. Remove the connecting rod caps.

#### When Reassembling:

1. Align the marks (A) with each other. (Face the marks toward the injection pump.)
2. Apply engine oil to the connecting rod screws and lightly screw them in by hand, then tighten them to the specified torque. If a connecting rod screw doesn't screw in smoothly, clean the threads. If the screw is still hard to screw in, replace it.

Connecting rod screws tightening torque	30.3 – 33.9 ft-lbs (4.2 – 4.7 kgf/m) (41.2 – 46.1 Nm)
---	---

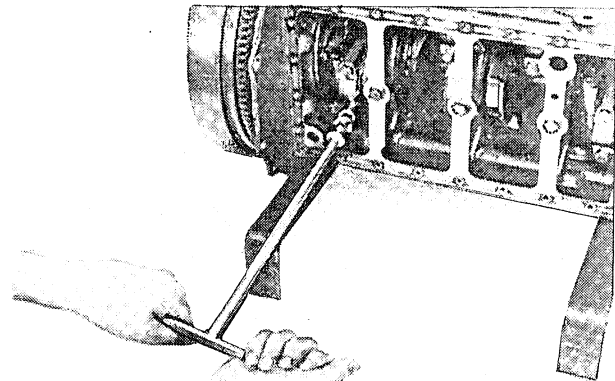

REMOVING CONNECTING ROD CAPS

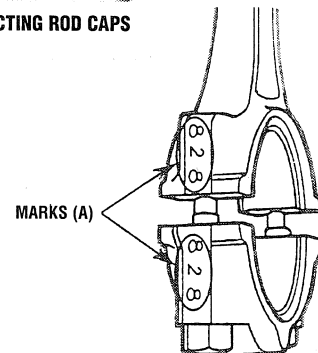

# ENGINE DISASSEMBLY & REASSEMBLY

## Piston

1. Turn the flywheel and bring the No. 1 piston to top dead center (TDC).
2. Pull the piston out upward by lightly tapping it from the bottom of the crankcase with the handle of a hammer.

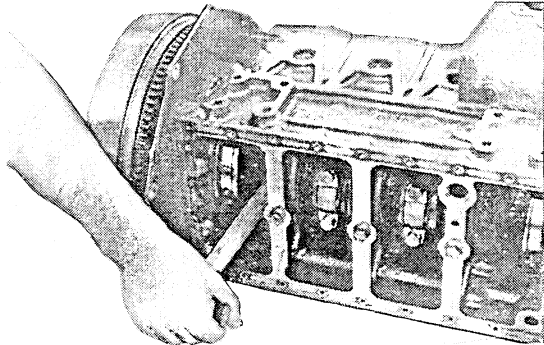

### When Reassembling:

1. Before inserting the piston into the cylinder, apply engine oil to the cylinder.
2. When inserting the piston into the cylinder, face the mark on the connecting rod toward the injection pump.

**NOTE:** Do not change the combinations of cylinder and piston. Make sure of the location of each piston by marking it. For example, mark "1" on the No. 1 piston.

3. When inserting the piston into the cylinder, place the gap of compression ring No. 1 on the side opposite the combustion chamber, and place the gaps of compression ring No. 2 and the oil ring at right angles from the gap of compression ring No. 1 (see illustration).
4. Carefully insert the pistons using a piston ring compressor, otherwise their chrome-plated sections may become scratched, causing trouble inside the liner.

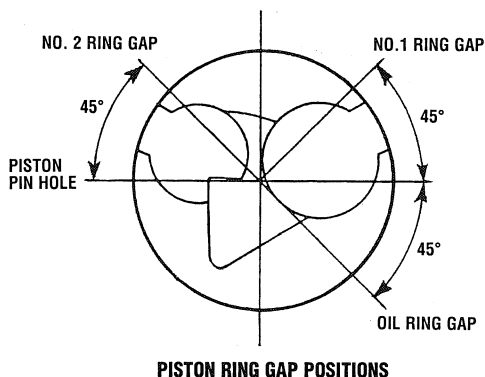
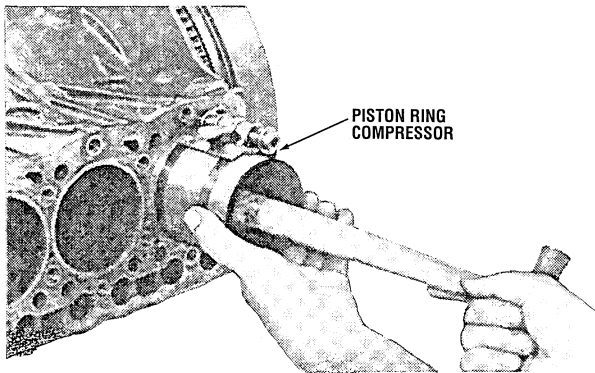

## Piston Ring and Connecting Rod

1. Remove the piston rings using a piston ring tool.
2. Align the casting mark (↑) on the piston as shown in the illustration.
3. Remove the piston pin and separate the connecting rod from the piston.

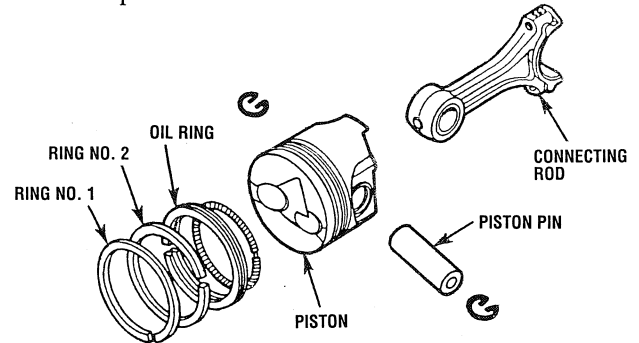

### When Reassembling:

1. When installing the rings, assemble them so that the manufacturer's mark near the gap faces the top of the piston.

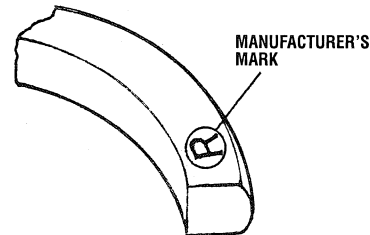

2. When installing the oil ring onto the piston, place the expander joint on the opposite side of the oil ring gap.

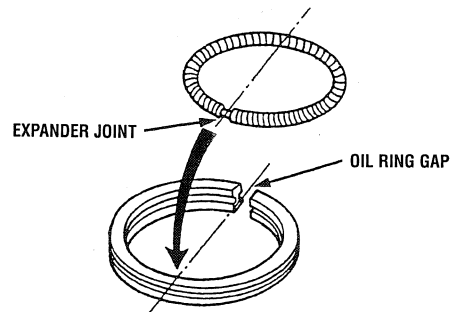

3. Apply engine oil to the piston pin.
4. Before installing the piston pin, immerse the piston in 176° F (80° C) oil for 10 to 15 minutes, then insert the piston pin into the piston.
5. When installing the connecting rod to the piston, align the mark on the connecting rod to the casting mark on the piston.

# ENGINE DISASSEMBLY & REASSEMBLY

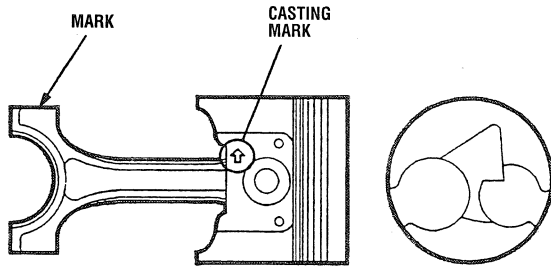

**NOTE:** Mark the same number on both the connecting rod and the piston so as not to change the combination.

## FLYWHEEL AND CRANKSHAFT

### Starter

1. Remove the starter.

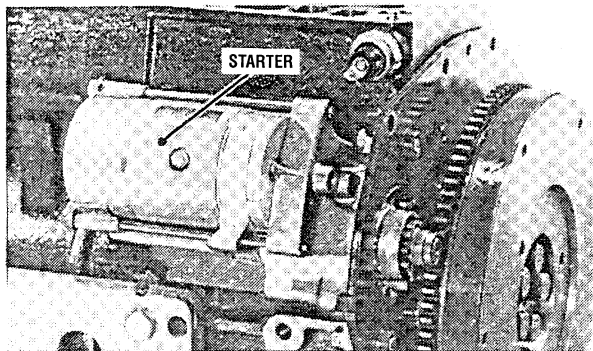

### Flywheel

1. Lock the flywheel so it will not turn.
2. Remove the flywheel screws, except for two which must be loosened and left as they are.
3. Use a flywheel puller and remove the flywheel, or work the flywheel off using two screwdrivers.

#### When Reassembling:

1. Apply engine oil to the flywheel screws.

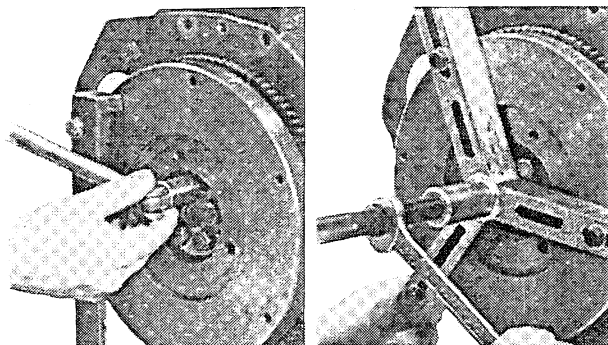

REMOVING THE FLYWHEEL

### Bearing Case Cover and Crankshaft

**NOTE:** Before disassembling, check the side clearance of the crankshaft. Also check it during reassembly.

1. Remove the bearing case cover mounting bolts. Unscrew the eight inside bolts first, then the nine outside bolts.
2. Screw two removed bolts into the right and left bolt holes of the bearing case cover to remove it.

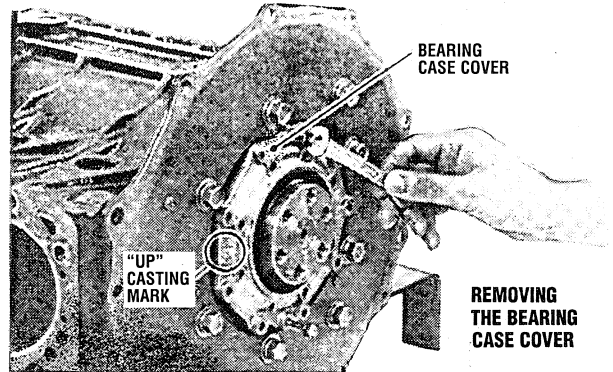

REMOVING THE BEARING CASE COVER

3. Remove the bearing case bolt 2.
4. Pull out the crankshaft.

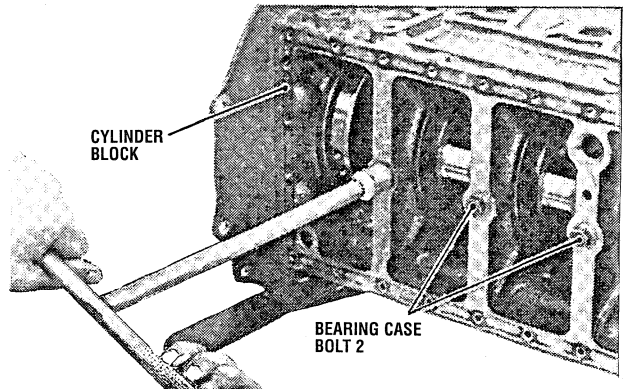

REMOVING THE BEARING CASE BOLTS

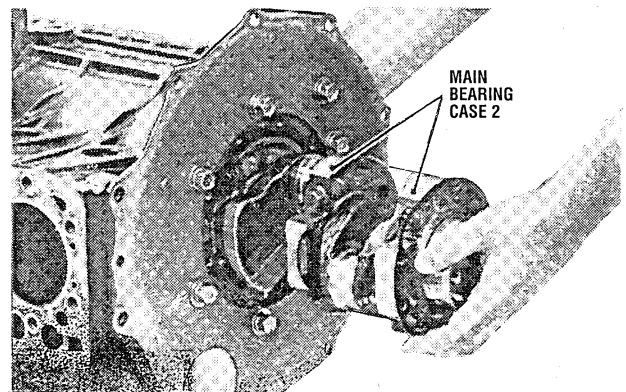

REMOVING THE CRANKSHAFT

# ENGINE DISASSEMBLY & REASSEMBLY

## When Reassembling:

1. Install the crankshaft sub-assembly, aligning the bolt hole of main bearing case 2 with the bolt hole in the cylinder block.
2. Apply engine oil to the seat and thread of bearing case bolt 2 and tighten it.
3. Install the bearing case cover with its casting mark "UP" facing upward.
4. Tighten the bearing case cover mounting bolts with even force on the diagonal line.

## Main Bearing Case Assembly

1. Remove the two main bearing case bolts 1, and remove the main bearing case assembly, being careful with the thrust bearings and crankshaft bearing 2.
2. Remove the main bearing case assemblies 1, 2 and 3 as above.

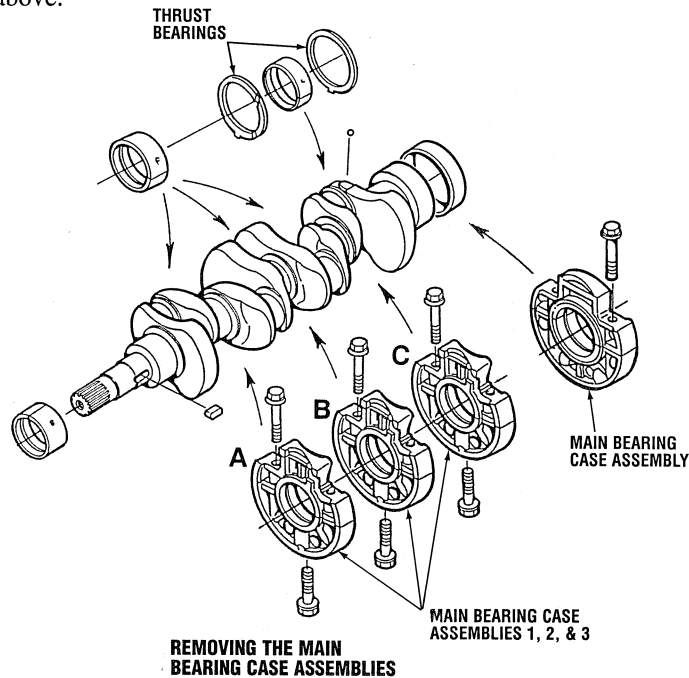

## When Reassembling:

1. Clean the oil passage in the main bearing case.
2. Apply clean engine oil on crankshaft bearing 2 and the thrust bearings.
3. Since the diameters of the main bearing case vary, install them in the order of the markings (A, B, C) from the gear case side.
4. When installing the main bearing case assemblies 1, 2 and 3, face the mark "FLYWHEEL" toward the flywheel.
5. Be sure to install the thrust bearing with its oil groove facing outward.

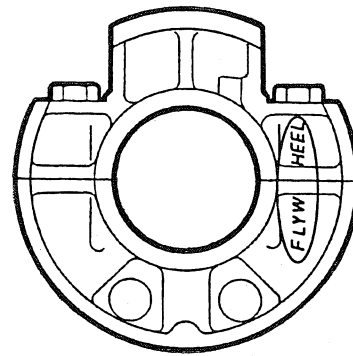

MAIN BEARING CASE ASSEMBLY

# ENGINE SERVICE

**NOTE:** Servicing specifications are included in this section. Also refer to the **SERVICE STANDARDS** section.

**NOTE:** Cylinder heads with serial numbers 489291 on up are partially modified because of the introduction of the nozzle heat seal. When replacing the cylinder head, see the parts list and choose the right one in reference to its serial number.

## CYLINDER HEAD

### Cylinder Head Distortion

1. Thoroughly clean the cylinder head surface.
2. Place a straightedge on the cylinder head and measure for distortion in the six directions **A** through **F** as shown in the illustration. Measure the clearance with a feeler gauge.

**NOTE:** Do not place the straightedge on the combustion chamber.

3. If the measurement exceeds the limit, correct it with a surface grinder.

**NOTE:** Be sure to check the valve recession after correcting.

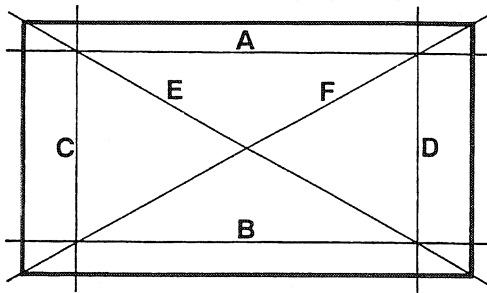
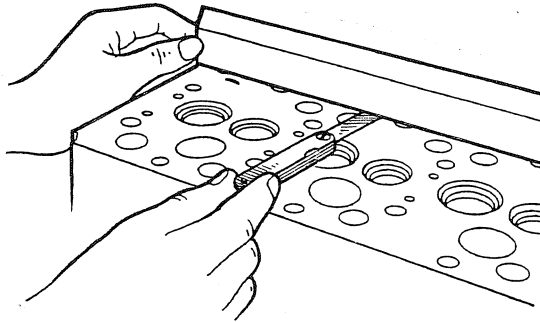

### Cylinder Head Flaw

1. Prepare an air spray red check.
2. Clean the surface of the cylinder head with detergent.
3. Spray the cylinder head surface with red permeative liquid. Wait five to ten minutes after spraying.
4. Wash away the red permeative liquid on the cylinder head surface with the detergent.
5. Spray the cylinder head surface with white developer.
6. If the surface is flawed, the flaws will be identified as red marks.

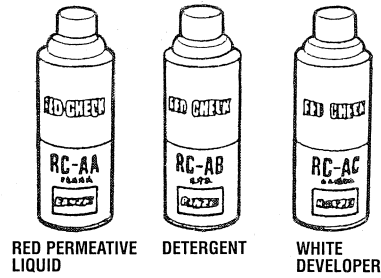

### Valve Recession

1. Clean the cylinder head, valve face and seat.
2. Insert the valve into the valve guide.
3. Measure the valve recession with a depth gauge.
4. If the measurement exceeds the limit, replace the valve. If the measurement still exceeds the limit after replacing the valve, correct the valve seat face of the cylinder head with a valve seat cutter or valve seat grinder. Then correct the cylinder head surface with a surface grinder, or replace the cylinder head.

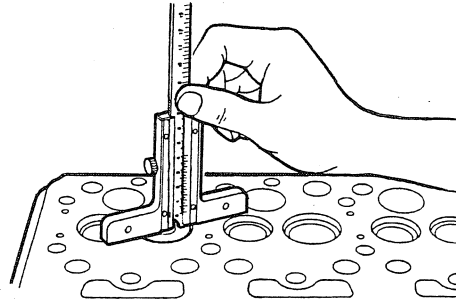

### Valve Stem to Valve Guide Clearance

1. Remove carbon from the valve guide.
2. Measure the valve stem O.D. with an outside micrometer.

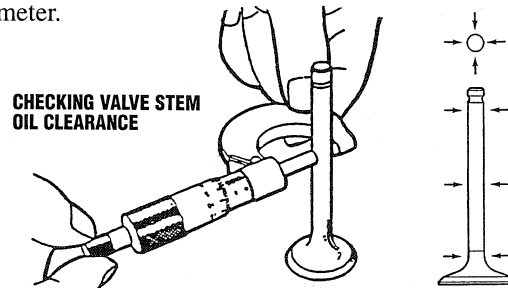

3. Using a small hole gauge, measure the valve guide I.D. where it shows maximum wear. Then calculate the clearance.
4. If the clearance exceeds the limit, replace the valve. If it still exceeds the limit, replace the valve guide.

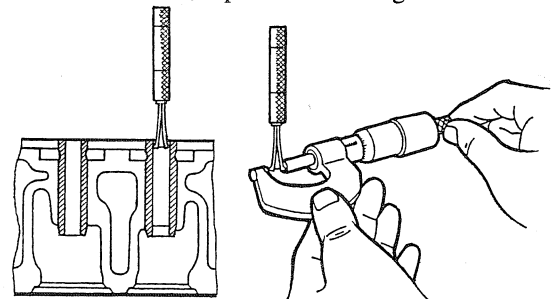

# ENGINE SERVICE

## Valve Seating

1. Coat the valve face lightly with prussian blue and put the valve on its seat to check the contact.
2. If the valve does not seat all the way around the seat or the valve contact is less than 70%, correct the valve seating as follows.
3. If the valve contact does not comply with the reference value, replace the valve or correct the valve seating.

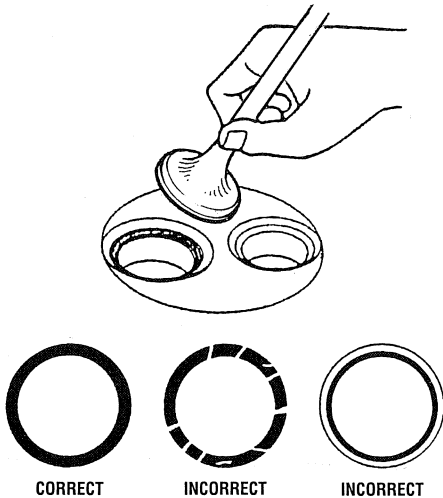

- c. After resurfacing the seat, inspect for even valve seating, then apply a thin film of compound between the valve face and valve seat and fit them with a valve lapping tool.
- d. Check the valve seating with prussian blue. The valve seating surface should show good contact all around.

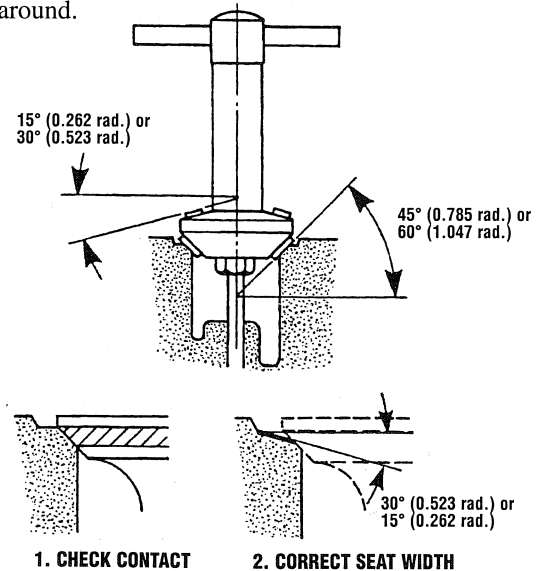

## Correcting Valve and Valve Seat

**NOTE:** Before correcting the valve and seat, check the valve stem and the I.D. of the valve guide, and repair them if necessary. After correcting the valve seat, be sure to check the valve recession.

### 1. Correcting the Valve

- a. Correct the valve with a valve refacer.

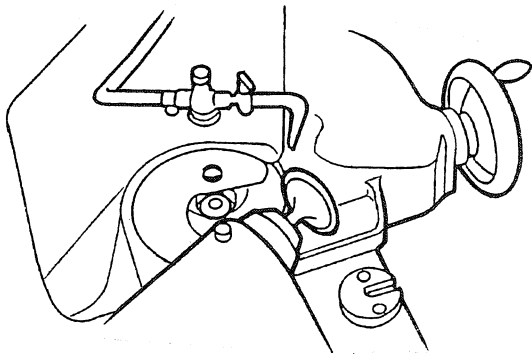

### 2. Correcting the Valve Seat

- a. Slightly correct the seat surface with a 60° (1.047 rad.) seat cutter (intake valve), or a 45° (0.785 rad.) seat cutter (exhaust valve).
- b. Resurface the seat surface with a 30° (0.523 rad.) valve seat cutter for the intake valve seat and with a 15° (0.262 rad.) valve seat cutter for the exhaust valve seat, so that the width is close to the specified valve seat width of 0.0835 in. (2.12 mm).

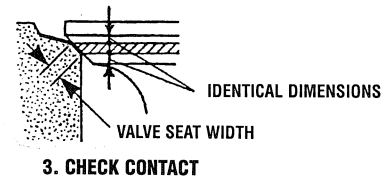

## Valve Lapping

1. Apply compound evenly to the valve lapping surface.
2. Insert the valve into the valve guide. Lap the valve onto its seat with a valve lapper or screwdriver.
3. After lapping the valve, wash the compound away and apply oil, then repeat the valve lapping with the oil.
4. Apply prussian blue to the contact surface to check the seated surface. If it is less than 70%, repeat the valve lapping again.

**NOTE:** When valve lapping is performed, be sure to check the valve recession, and adjust the valve clearance after assembling the valve.

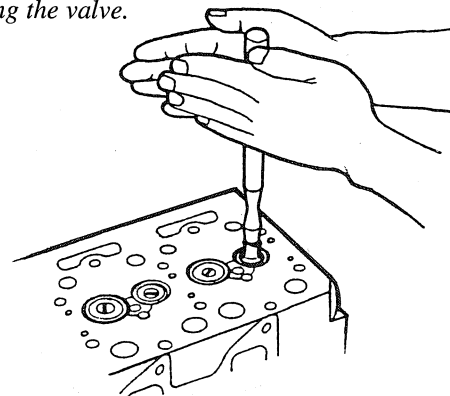

# ENGINE SERVICE

## Replacing Valve Guide

*When removing:*

1. Using a valve guide replacing tool (see *SPECIAL TOOLS*), press out the existing valve guide.

*When installing:*

2. Clean a new valve guide, and apply engine oil to it.
3. Using a valve guide replacing tool (see *SPECIAL TOOLS*), press in a new valve guide until it is flush with the cylinder head as shown in the illustration.
4. Ream the I.D. of the valve guide precisely to the specified dimension.

**CAUTION:** Do not hit the valve guide with a hammer during replacement; only use the valve guide replacing tool.

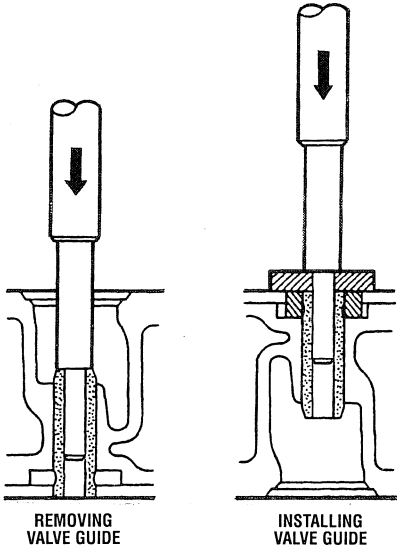

## Measuring Valve Spring

1. Measure the free length of the valve spring **A** with vernier calipers. If the measurement is less than the limit, replace it.
2. Put the spring on a level surface, place a square on the side of the spring, and check to see if the entire side is in contact with the square. Then rotate the spring and measure the maximum **B**. If the measurement exceeds the limit, replace the spring.
3. Check the entire surface of the spring for scratches, and replace the spring if there are any.

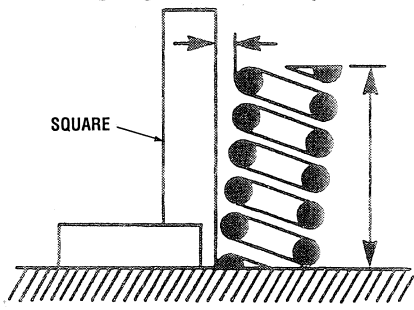

## Valve Spring Setting Load

1. Place the valve spring on a tester and compress it to the same length that it is compressed in the engine.
2. Read the compression load on the gauge.
3. If the measurement is less than the limit, replace the valve spring.

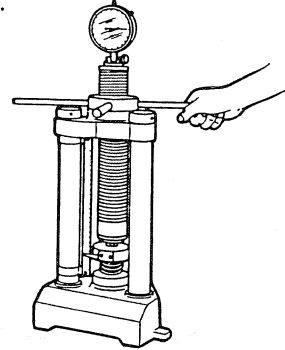

## Oil Clearance between Rocker Arm Shaft and Bearing

1. Measure the rocker arm bearing I.D. with an inside micrometer.
2. Measure the rocker arm shaft O.D. with an outside micrometer, then calculate the oil clearance.
3. If the clearance exceeds the limit, replace the rocker arm and measure the oil clearance again. If it still exceeds the limit, replace the rocker arm shaft also.

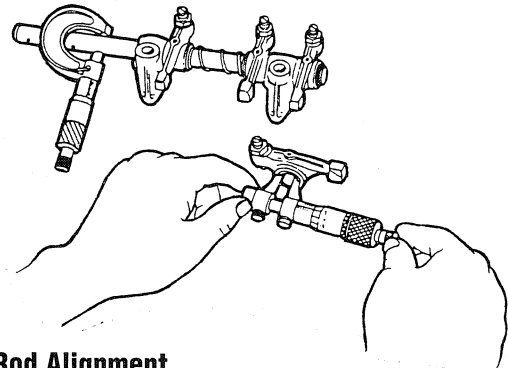

## Push Rod Alignment

1. Check both ends of the push rod for cracks, damage and unusual wear.
2. Measure the bending of the push rod with a dial indicator.
3. If the measurement exceeds the limit, replace the push rod.

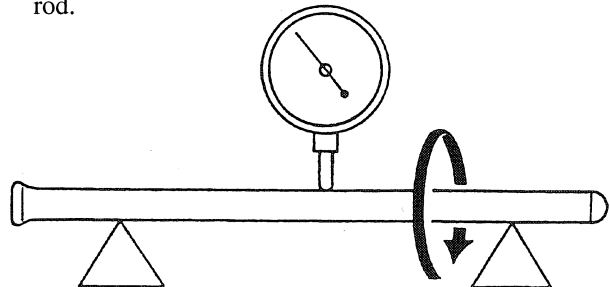



# ENGINE SERVICE

## Oil Clearance between Tappet and Tappet Guide Bore

1. Measure the tappet O.D. with an outside micrometer.
2. Measure the I.D. of the tappet guide bore with a cylinder gauge, and calculate the oil clearance.
3. If the oil clearance exceeds the limit or the tappet is damaged, replace the tappet.

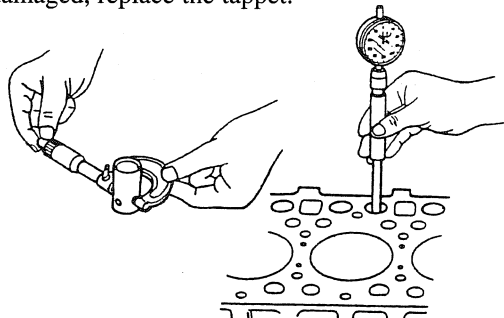

## TIMING GEARS AND CAMSHAFT

### Timing Gear Backlash

1. Set a dial indicator (lever type) with its tip on the gear tooth.
2. Move the gear to measure the backlash, holding its mating gear.
3. If the backlash exceeds the limit, check the oil clearance of the shaft and gear.
4. If the oil clearance is correct, replace the gear.

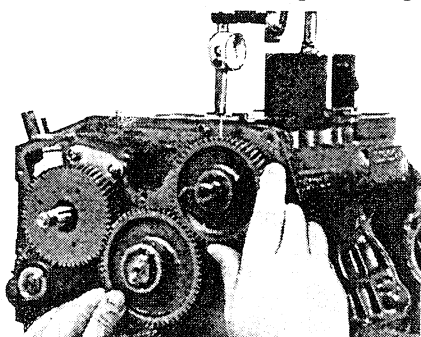

### Idle Gear Side Clearance

1. Set a dial indicator with its tip on the idler gear.
2. Measure the side clearance by moving the idler gear to the front and to the rear.
3. If the measurement exceeds the limit, replace the idler gear collar.

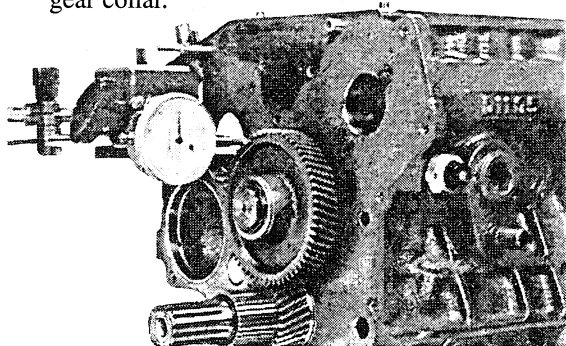

## Camshaft Side Clearance

1. Set a dial indicator with its tip on the camshaft.
2. Measure the side clearance by moving the cam gear to the front and to the rear.
3. If the measurement exceeds the limit, replace the camshaft stopper.

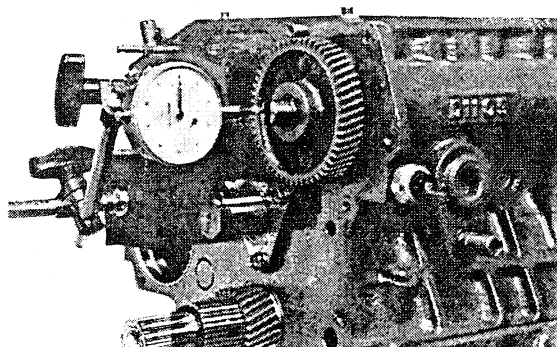

## Camshaft Alignment

1. Support the camshaft with V blocks on the surface plate and set a dial indicator with its tip on the intermediate journal at a right angle.
2. Rotate the camshaft on the V blocks and get the misalignment (half of the measurement).
3. If the misalignment exceeds the limit, replace the camshaft.

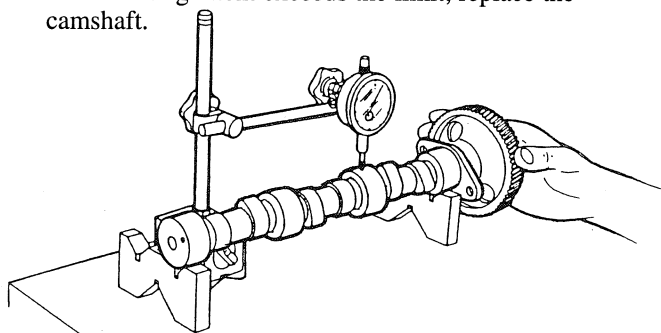

## Cam Height

1. Measure the height of the cam at its highest point with an outside micrometer.
2. If the measurement is less than the limit, replace the camshaft.

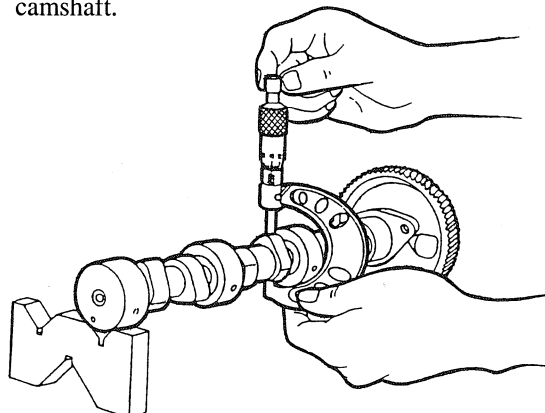

# ENGINE SERVICE

## Camshaft Journal Oil Clearance

1. Measure the camshaft journal O.D. with an outside micrometer.
2. Measure the cylinder block bore I.D. for the camshaft with an inside micrometer. Calculate the oil clearance.
3. If the clearance exceeds the limit, replace the camshaft.

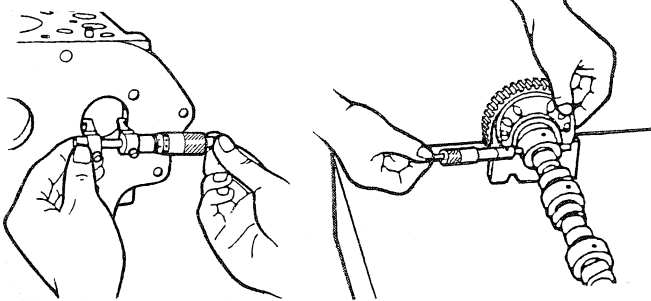

## Oil Clearance between Idler Gear Shaft and Idler Gear Bushing

1. Measure the idler gear shaft O.D. with an outside micrometer.
2. Measure the idler gear bushing's I.D. with an inside micrometer, and calculate the oil clearance.
3. If the oil clearance exceeds the limit, replace the bushing.

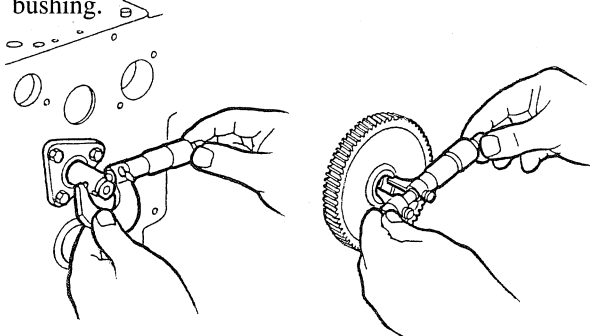

## Replacing the Idler Gear Bushing

1. Using an idler gear bushing replacing tool (see *SPECIAL TOOLS*), press out the existing bushing.
2. Clean a new idler gear bushing and the idler gear bore, and apply engine oil to them.
3. Using the idler gear bushing replacing tool, press in a new bushing to the specified dimension (see illustration).

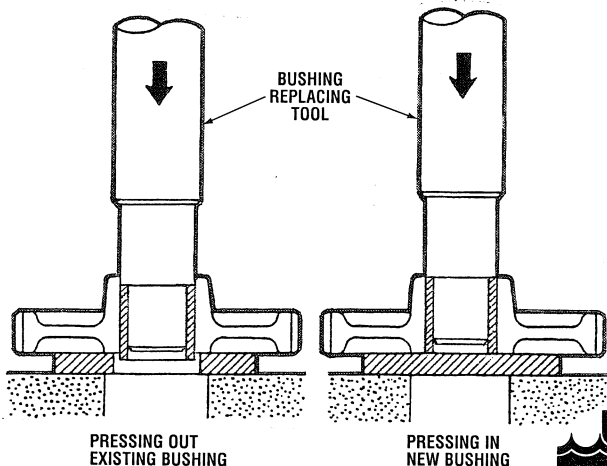

## PISTON AND CONNECTING ROD

### Piston Pin Bore I.D.

1. Measure the piston pin bore I.D. in both the horizontal and vertical directions with a cylinder gauge.
2. If the measurement exceeds the limit, replace the piston.

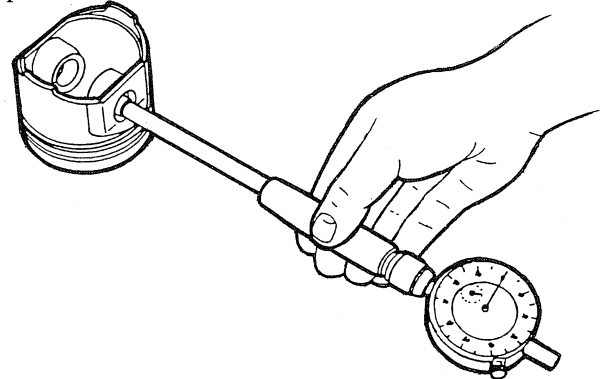

### Oil Clearance between Piston Pin and Connecting Rod Small End Bushing

1. Measure the O.D. of the piston pin where it contacts the bushing with an outside micrometer.
2. Measure the I.D. of the piston pin bushing at the connecting rod small end with a cylinder gauge. Calculate the oil clearance.
3. If the clearance exceeds the limit, replace the bushing. If it still exceeds the limit, replace the piston pin.

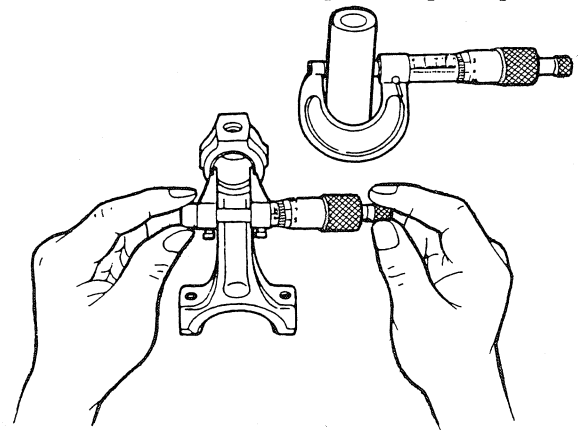

### Replacing Connecting Rod Small End Bushing

#### When removing:

1. Press out the existing bushing using a small end bushing replacing tool.

#### When installing:

1. Clean a new small end bushing and bore, and apply engine oil to them.
2. Insert the new bushing onto the tool and press-fit it so that the seam of the bushing is positioned as shown in the illustration and the bushing is flush with the connecting rod.

# ENGINE SERVICE

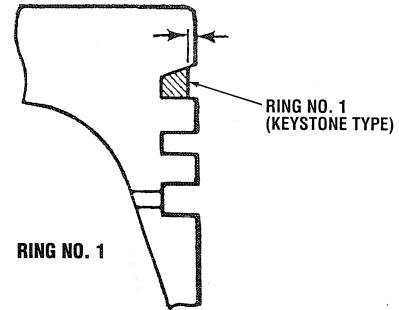
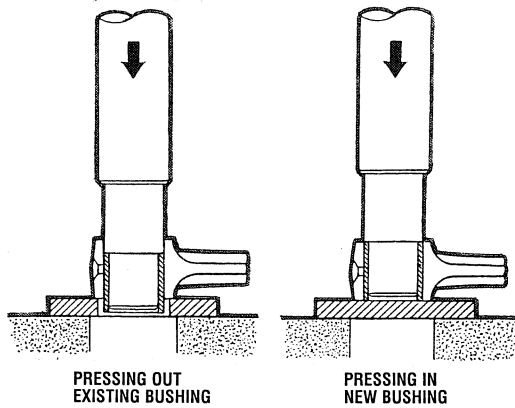

3. Drill a hole through the bushing, aligning with the oil hole in the connecting rod. Use a 0.157 in (4.0 mm) dia. drill.

**NOTE:** Be sure to chamfer the oil hole with an oilstone.

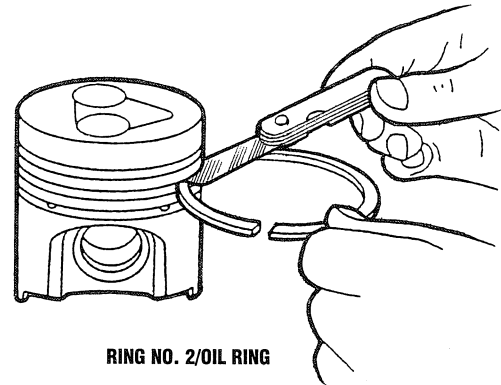
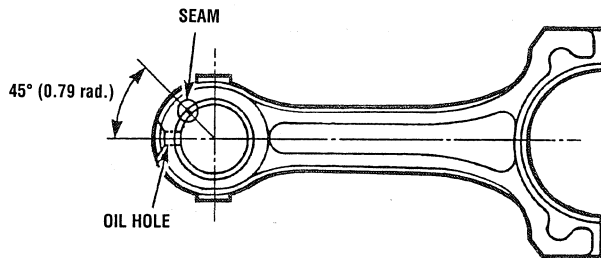

## Piston Ring Gap

1. Insert the piston ring into the lower part of the liner (the least worn out part of the liner) using the piston.
2. Measure the ring gap with a feeler gauge.
3. If the gap exceeds the limit, replace the piston ring.

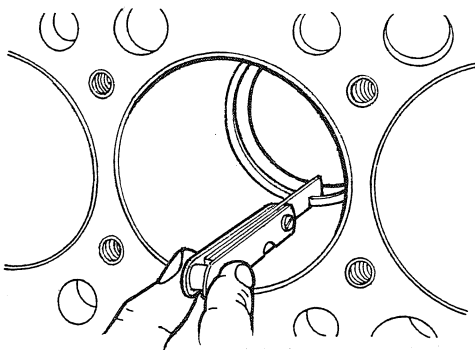

## Piston Ring Clearances

1. Remove carbon from the ring grooves.
2. For Ring No.1 (keystone type), measure the clearance between the outer side of the ring and the side of the piston.
3. For Ring No.2 and the Oil Ring, measure the clearance between the rings and the grooves with a feeler gauge or depth gauge.
4. If a clearance exceeds the limit, replace the ring.
5. If the clearance still exceeds the limit after replacing the ring, replace the piston.

## PISTON RING CLEARANCES

	STANDARD VALUE	LIMIT
Ring No.1 (Keystone Type)		0.0079 in. (0.20 mm)
Ring No.2	0.0033 – 0.0044 in. (0.085 – 0.112 mm)	0.0079 in. (0.20 mm)
Oil Ring	0.0008 – 0.0021 in. (0.020 – 0.055 mm)	0.0059 in. (0.15 mm)

## Connecting Rod Alignment

**NOTE:** Since the I.D. of the connecting rod small end bushing is the basis of this check, check this bushing for wear beforehand.

1. Remove the crankpin bearing, and install the connecting rod cap.
2. Install the piston pin in the connecting rod.
3. Install the connecting rod on the connecting rod alignment tool.
4. Put a gauge over the piston pin, and move it against the face plate.
5. If the gauge does not fit squarely against the face plate, measure the space between the pins of the gauge and the face plate.
6. If the measurement exceeds the limit, replace the connecting rod.

# ENGINE SERVICE

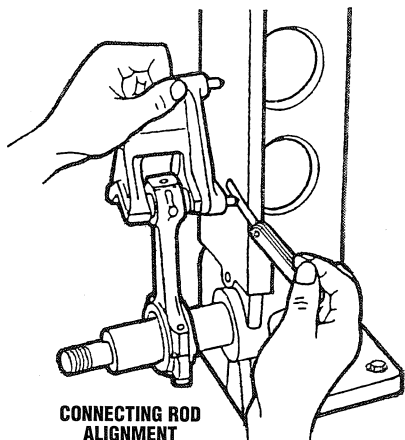

CONNECTING ROD ALIGNMENT

## CRANKSHAFT

### Crankshaft Side Clearance

1. Set a dial indicator with its tip on the end of the crankshaft.
2. Measure the side clearance by moving the crankshaft to the front and to the rear.
3. If the measurement exceeds the limit, replace the thrust bearings.
4. If a same-size thrust bearing is inadequate because of crankshaft journal wear, replace it with an oversize thrust bearing (see illustration and table).

	STANDARD VALUE	LIMIT
Crankshaft side clearance	0.0059 – 0.0122 in. (0.15 – 0.31 mm)	0.0197 in. (0.50 mm)

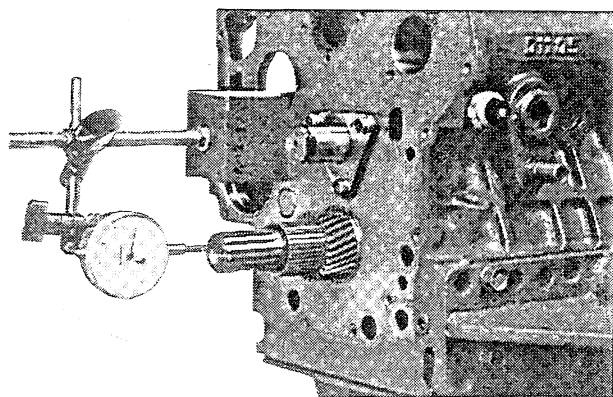

### OVERSIZE THRUST BEARING

OVERSIZE	BEARING	MARKING
0.008 in. (0.2 mm)	Thrust bearing No. 1 02	020 OS
	Thrust bearing No. 2 02	
0.016 in. (0.4 mm)	Thrust bearing No. 1 04	040 OS
	Thrust bearing No. 2 04	

### OVERSIZE DIMENSIONS OF CRANKSHAFT JOURNAL

Dimension \ Oversize	0.008 in (0.2 mm)	0.016 in (0.4 mm)
A	1.1102 – 1.1122 in. (28.20 – 28.25 mm)	1.1181 – 1.1201 in. (28.40 – 28.45 mm)
B	2.028 – 2.035 in. (51.5 – 51.7 mm)	2.031 – 2.039 in. (51.6 – 51.8 mm)
C	0.091 – 0.106 in. radius (2.3 – 2.7 mm radius)	0.091 – 0.106 in. radius (2.3 – 2.7 mm radius)

(0.8-S)  
The crankshaft journal must be fine-finished to higher than  $\nabla\nabla\nabla$

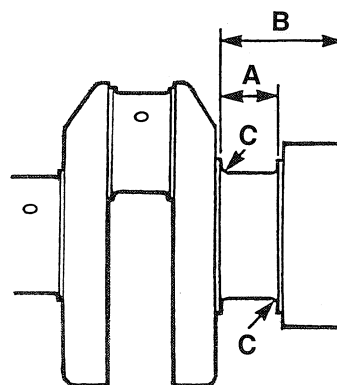

### Crankshaft Alignment

1. Support the crankshaft with V blocks on the surface plate and set a dial indicator with its tip on the intermediate journal at a right angle.
2. Rotate the crankshaft on the V blocks and get the misalignment (half of the measurement).
3. If the misalignment exceeds the limit, replace the crankshaft.

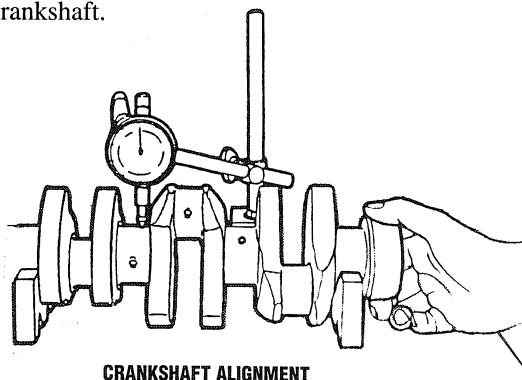

CRANKSHAFT ALIGNMENT

### Oil Clearance between Crankpin and Crankpin Bearing

1. Clean the crankpin and crankpin bearing.
2. Put a strip of plastigauge on the center of the crankpin.
3. Install the connecting rod cap and tighten the connecting rod screws to the specified torque, then remove the cap.

# ENGINE SERVICE

4. Measure the amount of flattening with the scale, and get the oil clearance.

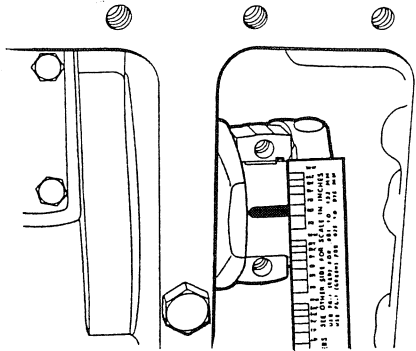

5. If the oil clearance exceeds the limit, replace the crankpin bearing.
6. If a same-size bearing is too big because of crankpin wear, replace it with an undersize bearing (see illustration and table).

**NOTE:** Never insert the plastigauge into the crankpin oil hole. Be sure not to move the crankshaft while the connecting rod screws are tightened.

	STANDARD VALUE	LIMIT
Oil Clearance between crankpin and crankpin bearing	0.00114 – 0.00358 in. (0.029 – 0.091 mm)	0.0079 in. (0.20 mm)

	STANDARD VALUE
Crankpin O.D.	1.57319 – 1.57382 in. (39.959 – 39.975 mm)
Crankpin bearing I.D.	1.57496 – 1.57677 in. (40.004 – 40.050 mm)

## UNDERSIZE CRANKPIN BEARING

UNDERSIZE	BEARING	MARKING
0.008 in. (0.2 mm)	Crankpin bearing 02	020 US
0.016 in. (0.4 mm)	Crankpin bearing 04	040 US

## UNDERSIZE DIMENSIONS OF CRANKPINS

Undersize Dimension	0.008 in. (0.2 mm)	0.016 in. (0.4 mm)
<b>A</b>	0.1102 – 0.1260 in. radius (2.8 – 3.2 mm radius)	0.1102 – 0.1260 in. radius (2.8 – 3.2 mm radius)
<b>B</b>	0.0394 – 0.0591 in. radius (1.0 – 1.5 mm radius)	0.0394 – 0.0591 in. radius (1.0 – 1.5 mm radius)
<b>C</b>	1.56531 – 1.56594 in. (39.759 – 39.775 mm)	1.55744 – 1.55807 in. (39.559 – 39.575 mm)
(0.8-S)		
The crankpin must be fine-finished to higher than $\nabla\nabla\nabla$		

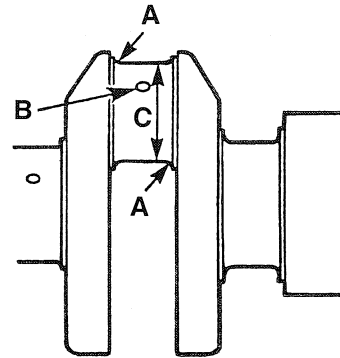

## Oil Clearance between Crankshaft Journal and Crankshaft Bearing No.1

1. Measure the O.D. of the crankshaft's front journal with an outside micrometer.

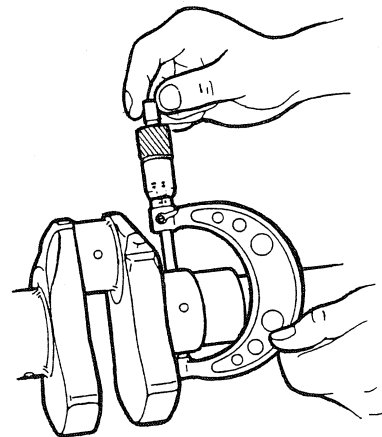

2. Measure the I.D. of the crankshaft bearing No. 1 with an inside micrometer, and calculate the oil clearance.

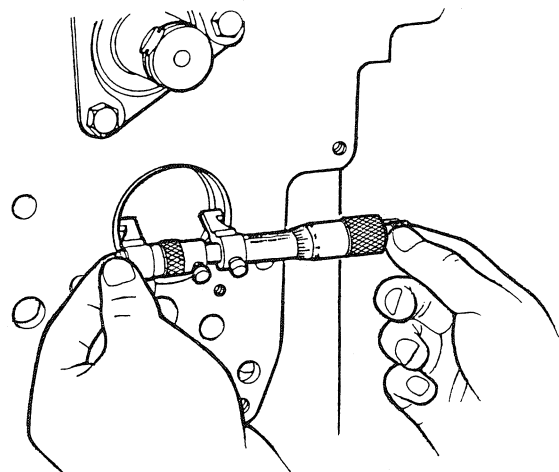

3. If the oil clearance exceeds the limit, replace crankshaft bearing No. 1.
4. If a same-size bearing is too big because of crankshaft journal wear, replace it with an undersize bearing (see illustration and table).

# ENGINE SERVICE

	STANDARD VALUE	LIMIT
Oil Clearance between crankshaft journal and crankshaft bearing No. 1	0.00134 – 0.00449 in. (0.034 – 0.114 mm)	0.0079 in. (0.20 mm)

	STANDARD VALUE
Crankshaft journal O.D.	1.88716 – 1.88779 in. (47.934 – 47.950 mm)
Crankshaft bearing No. 1 I.D.	1.88913 – 1.89165 in. (47.984 – 48.048 mm)

## UNDERSIZE CRANKSHAFT BEARING NO. 1

UNDERSIZE	BEARING	MARKING
0.008 in. (0.2 mm)	Crankshaft bearing No. 1 02	020 US
0.016 in. (0.4 mm)	Crankshaft bearing No. 1 04	040 US

## UNDERSIZE DIMENSIONS OF CRANKSHAFT JOURNAL

Undersize Dimension	0.008 in. (0.2 mm)	0.016 in. (0.4 mm)
<b>A</b>	0.0906 – 0.1063 in. radius (2.3 – 2.7 mm radius)	0.0906 – 0.1063 in. radius (2.3 – 2.7 mm radius)
<b>B</b>	0.0394 – 0.0591 in. radius (1.0 – 1.5 mm radius)	0.0394 – 0.0591 in. radius (1.0 – 1.5 mm radius)
<b>C</b>	1.87929 – 1.87992 in. (47.734 – 47.750 mm)	1.87142 – 1.87204 in. (47.534 – 47.550 mm)

(0.8-S)

The crankshaft journal must be fine-finished to higher than  $\nabla\nabla\nabla\nabla$

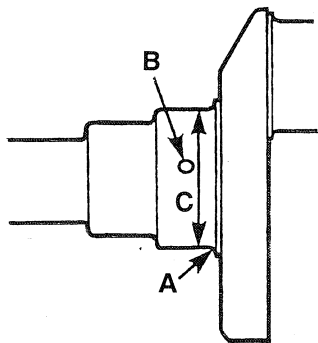

## Replacing Crankshaft Bearing No. 1

### When removing:

1. Press out the existing crankshaft bearing No. 1 using a crankshaft bearing No 1 replacing tool.

### When installing:

1. Clean a new crankshaft bearing No. 1 and the crankshaft journal bore, then apply engine oil to them.
2. Using the crankshaft bearing No. 1 replacing tool, press in a new bearing No. 1 so that its seam faces the exhaust manifold side.

	STANDARD VALUE
Dimension A	0 – 0.0118 in. (0 – 0.3 mm)

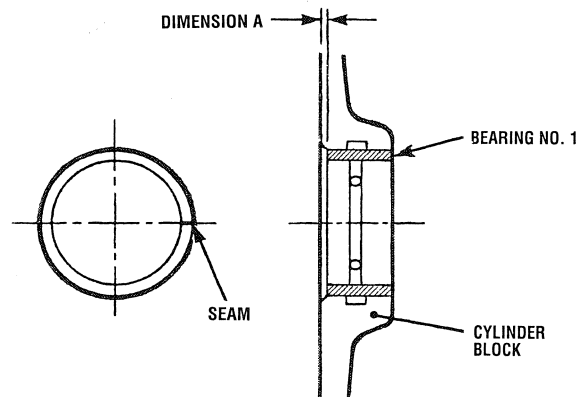

## Oil Clearance between Crankshaft Journal and Crankshaft Bearings No. 2 & No. 3

1. Put a strip of plastigauge on the center of the journal.
2. Install the bearing case and tighten the bearing case screws to the specified torque, then remove the bearing case.
3. Measure the amount of the flattening with the scale, and get the oil clearance.

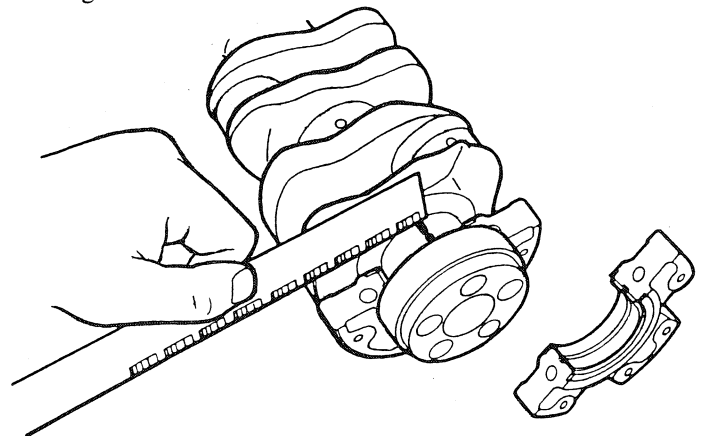

4. If the oil clearance exceeds the limit, replace the crankshaft bearing.
5. If a same-size bearing is too big because of the crankshaft journal wear, use an undersize one (see illustration and table).

**NOTE:** Be sure not to move the crankshaft while the bearing case screws are being tightened.

	STANDARD VALUE	LIMIT
Oil Clearance between crankshaft journal and crankshaft bearing No. 2	0.00134 – 0.00374 in. (0.034 – 0.095 mm)	0.0079 in. (0.20 mm)

# ENGINE SERVICE

	STANDARD VALUE
Crankshaft journal O.D. (intermediate)	1.88716 – 1.88779 in. (47.934 – 47.950 mm)
Crankshaft bearing No. 2 I.D.	1.88913 – 1.89091 in. (47.984 – 48.029 mm)

	STANDARD VALUE	LIMIT
Oil Clearance between crankshaft journal and crankshaft bearing No. 3	0.00134 – 0.00386 in. (0.034 – 0.098 mm)	0.0079 in. (0.20 mm)

	STANDARD VALUE
Crankshaft journal O.D. (flywheel side)	2.04413 – 2.04488 in. (51.921 – 51.940 mm)
Crankshaft bearing No. 3 I.D.	2.04622 – 2.04799 in. (51.974 – 52.019 mm)

## UNDERSIZE CRANKSHAFT BEARINGS NO. 2 & NO. 3

UNDERSIZE	BEARING	MARKING
0.008 in. (0.2 mm)	Crankshaft bearing No. 2 02 Crankshaft bearing No. 3 02	020 US
0.016 in. (0.4 mm)	Crankshaft bearing No. 2 04 Crankshaft bearing No. 3 04	040 US

## UNDERSIZE DIMENSIONS OF CRANKSHAFT JOURNAL

Undersize Dimension	0.008 in. (0.2 mm)	0.016 in. (0.4 mm)
<b>A</b>	0.0906 – 0.1063 in. radius (2.3 – 2.7 mm radius)	0.0906 – 0.1063 in. radius (2.3 – 2.7 mm radius)
<b>B</b>	0.0394 – 0.0591 in. radius (1.0 – 1.5 mm radius)	0.0394 – 0.0591 in. radius (1.0 – 1.5 mm radius)
<b>C</b>	1.87929 – 1.87992 in. (47.734 – 47.750 mm)	1.87141 – 1.87204 in. (47.534 – 47.550 mm)
<b>D</b>	2.03626 – 2.03700 in. (51.721 – 51.740 mm)	2.02838 – 2.02913 in. (51.521 – 51.540 mm)

(0.8-S)

The crankshaft journal must be fine-finished to higher than  $\nabla\nabla\nabla$

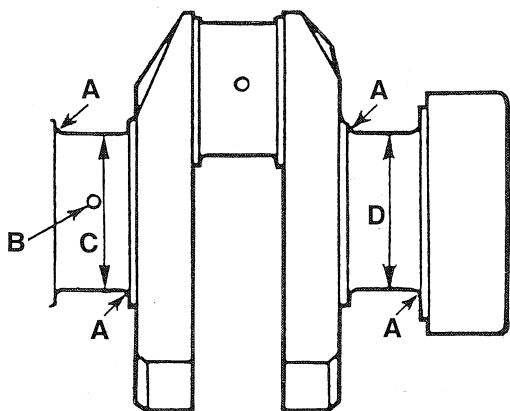

## CYLINDER

### Cylinder Wear

1. Measure the I.D. of the cylinder at the six positions shown in the illustration with a cylinder gauge to find the maximum and minimum I.D.'s.

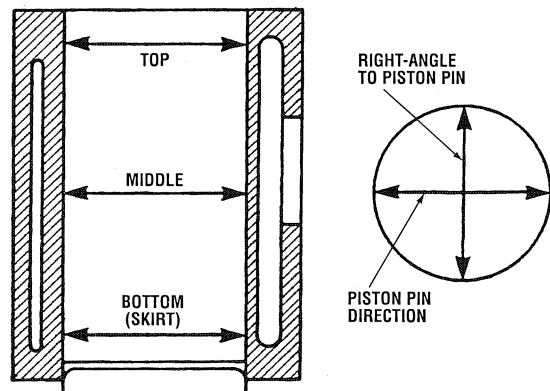
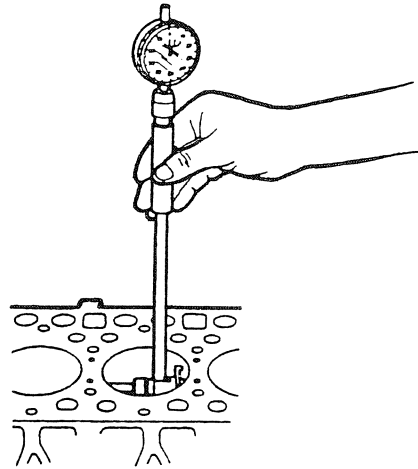

2. Determine the difference (maximum wear) between the maximum and minimum I.D.'s.
3. If the maximum wear exceeds the limit, bore and hone to the oversize dimension (see *Correcting Cylinder*, below).
4. Visually check the cylinder wall for scratches. If deep scratches are found, the cylinder should be bored (see *Correcting Cylinder*, below).

	STANDARD VALUE	LIMIT
Cylinder I.D.		
M-25 XPB	2.9921 – 2.9929 in. (76.000 – 76.019 mm)	—
M-35B		
M-40B	3.0709 – 3.0716 in. (78.000 – 78.019 mm)	—
Maximum Wear	—	0.0059 in. (0.15 mm)

# ENGINE SERVICE

## Correcting Cylinder

1. When the cylinder is worn beyond the limit, bore and hone it to the specified dimension.

	STANDARD VALUE	LIMIT
Cylinder I.D. M-25XPB M-35B M-40B	3.0118 – 3.0126 in. (76.500 – 76.519 mm) 3.0906 – 3.0913 in. (78.500 – 78.519 mm)	— —
Maximum Wear	—	0.0059 in. (0.15 mm)
Finishing	Hone to 0.00047 – 0.00079 in.R max. (1.2 – 2.0 μR max.)	

2. Replace the piston and the piston rings with oversize (0.5 mm) rings.

	MODEL	MARKING
Piston	M-25XPB M-35B M-40B	05 OS
Piston Ring Assembly	M-25XPB M-35B M-40B	05 OS

**NOTE:** When an oversize cylinder is worn beyond the limit, sleeve the block to return the cylinder to the standard size.

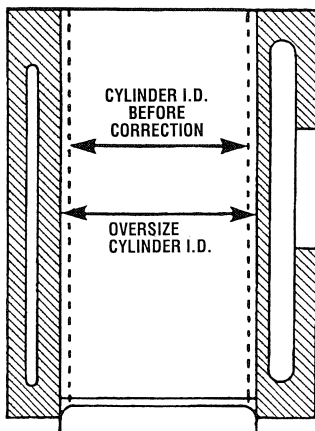



# ENGINE ADJUSTMENTS

**NOTE:** UNIVERSAL recommends that the following engine adjustments be performed by a competent engine mechanic. The information below is provided to assist the mechanic.

## VALVE CLEARANCE ADJUSTMENT

**NOTE:** Valve adjustments should not be necessary under normal operating conditions. These adjustments, when required, should be performed by an authorized mechanic.

Remove the valve rocker cover to expose the engine's valve train. Remove the glow plugs from each of the cylinders to enable the engine to be easily rotated by hand to position each cylinder for valve adjustment.

The valves are adjusted with the piston in the cylinder positioned at TDC (Top Dead Center) of its compression stroke. Each cylinder is adjusted following the engine's firing order.

**Firing Order:** 3 Cylinder Models 1-2-3  
4 Cylinder Models 1-3-4-2

Adjust the valves beginning with Cylinder No. 1. Rotate the crankshaft slowly and observe the operation of the valves for Cylinder No.1. Watch for the intake valve to open indicating the piston is on its intake stroke (the piston is moving down in the cylinder). Continue to rotate the crankshaft slowly and look for the intake valve to close. The piston is now starting its compression stroke (the piston is moving up in the cylinder towards TDC).

Watch the timing hole in the bellhousing for the timing numbers to appear. Position the ITC mark in alignment with the notch in the timing hole. The piston in Cylinder No. 1 is now at TDC. Adjust the valves in Cylinder No. 1. Proceed to the next cylinder in the firing order.

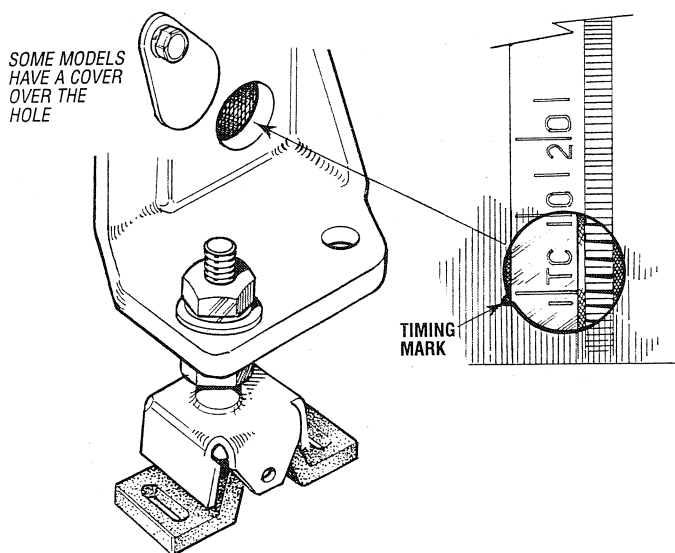

## Three Cylinder Models

Rotate the crankshaft 240° in the normal direction of rotation and adjust the No. 2 Cylinder's valves. Rotate the crankshaft another 240° and adjust the No. 3 Cylinder's valves.

## Four Cylinder Models

Rotate the crankshaft 180° in the normal direction of rotation and adjust the No. 3 Cylinder's valves. Rotate the crankshaft another 180° and adjust the No. 4 Cylinder's valves. Rotate the crankshaft another 180° and adjust the No. 2 Cylinder's valves.

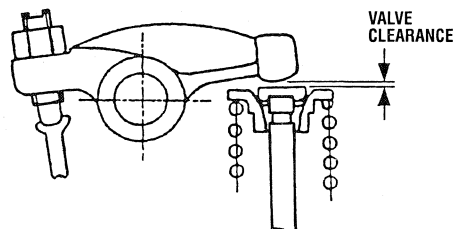

	STANDARD VALUE
Valve clearance (engine cold)	0.0071 – 0.0087 in. (0.18 – 0.22 mm)

## TOP CLEARANCE

1. Remove the cylinder head (remove the cylinder head gasket completely).
2. Bring the piston to its top dead center. Measure the top clearance using a plastigauge. Position the plastigauge on the piston top.
3. Bring the piston to its middle position, install the cylinder head, and tighten the cylinder head bolts to their specified torque. (The head gasket must be changed to a new one.)
4. Turn the crankshaft until the piston exceeds its top dead center.
5. Remove the cylinder head and measure the clearance.
6. If the measurement is not within the standard value, check the oil clearance of the crankpin journal and the piston pin.

Top clearance	Standard value	0.0217– 0.0295 in. (0.55 – 0.75 mm)

Tightening torque	Cylinder head mounting bolts	47.0 – 50.6 ft-lbs (6.5 – 7.0 kgf/m) (63.7 – 68.6 Nm)

## TIGHTENING THE CYLINDER HEAD BOLTS

Pull off the air breather pipe from the rocker cover and remove the rocker cover. Retighten the cylinder head bolts to their specified torque as shown in the diagram. Make sure the engine is cold when this is done. Before applying the specified torque to a bolt, loosen it 1/4 to 1/2 a turn and then apply the torque.

# ENGINE ADJUSTMENTS

**NOTE:** *UNIVERSAL recommends that the following engine adjustments be performed by a competent engine mechanic. The information below is provided to assist the mechanic.*

Tighten the cylinder head bolts in an ascending sequence:

Model M-25XPB – from 1 to 14

Model M-35B – from 1 to 18

Model M-40B – from 1 to 18

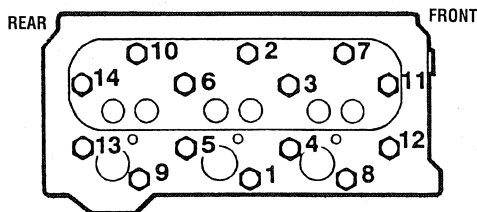

MODEL M-25XPB

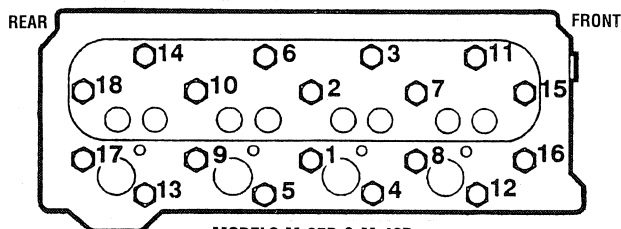

MODELS M-35B & M-40B

## OIL PRESSURE

The engine's oil pressure, during operation, is indicated by the oil pressure gauge on the instrument panel. During normal operation, the oil pressure will range between 40 and 60 psi (2.8 and 4.2 kg/cm<sup>2</sup>).

**NOTE:** *A newly started, cold engine can have an oil pressure reading up to 60 psi (4.2 kg/cm<sup>2</sup>). A warmed engine can have an oil pressure reading as low as 35 psi (2.5 kg/cm<sup>2</sup>). These readings will vary depending upon the temperature of the engine and the rpms.*

### Low Oil Pressure

The specified safe minimum oil pressure is 5 – 10 psi (0.35 – 0.70 kg/cm<sup>2</sup>). A gradual loss of oil pressure usually indicates worn bearings. For additional information on low oil pressure readings, see *ENGINE TROUBLE SHOOTING*.

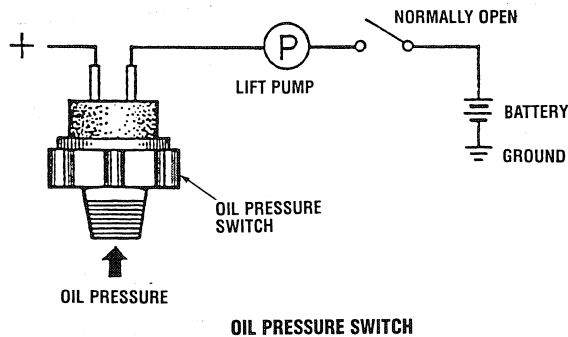

## Checking the Oil Pressure

1. Remove the oil pressure switch and install a mechanical oil pressure gauge in its place.
2. Start the engine. After warming up to operating temperature, measure the oil pressure at both idling and rated speeds.
3. If the oil pressure is less than the specified limit, check the following:
  - a. Engine oil insufficient.
  - b. Oil pump defective.
  - c. Oil strainer clogged.
  - d. Oil filter.
  - e. Oil gallery clogged.
  - f. Excessive oil clearance of bearing.
  - g. Foreign matter in the relief valve.

### When Reassembling:

1. After checking the engine oil pressure, tighten the engine oil pressure switch to the specified torque.

#### Oil pressure at idle speed:

15 psi (1.05 kg/cm<sup>2</sup>) (103.4 kPa)

#### Oil pressure at rated speed:

40 – 60 psi (2.8 – 4.2 kg/cm<sup>2</sup>) (276 – 414 kPa)

#### Oil pressure switch torque:

10.8 – 14.5 ft-lb (1.5 – 2.0 kg-m)

## TESTING ENGINE COMPRESSION

Make certain the oil level (dipstick) is at the correct level and the air intake filter is clean. The battery and starter motor must also be in good condition.

1. Warm the engine to normal operating temperature.
2. Move the control lever to a position for shutting off the fuel. (Disconnect the wires if a fuel shutdown solenoid is used.)
3. Remove all the glow plugs from the engine and install the compression gauge/adaptor combination to the cylinder on which the compression is to be measured.

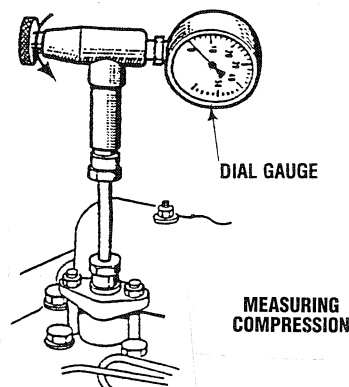

# ENGINE ADJUSTMENTS

**NOTE:** *UNIVERSAL recommends that the following engine adjustments be performed by a competent engine mechanic. The information below is provided to assist the mechanic.*

4. Close the raw water seacock (thru-hull).
5. Crank the engine and allow the gauge to reach a maximum reading. Record the reading.
6. Repeat this process for each cylinder. Look for cylinders with dramatically (at least 20%) lower compression than the average of the others.

## Compression pressure at cranking speed:

**Standard value:** 412 – 469 psi (29 – 33 kgf/cm<sup>2</sup>)  
(2.84 – 3.24 MPa)

**Limit:** 327 psi (23 kgf/cm<sup>2</sup>) (2.26 MPa)

**Maximum difference between cylinders:**  
10% or less.

**NOTE:** *If the readings are below the limit, the engine needs an overhaul.*

7. Re-install the glow plugs (use anti-seize compound on the threads) and reset the fuel shut-off to the run position.
8. **Open the raw water seacock (thru-hull).**

If a weak cylinder is flanked by healthy cylinders, the problem is either valve- or piston- related. Check the valve clearances for the weak cylinder, adjust as needed, and test again. If the cylinder is still low, apply a small amount of oil into the cylinder to seal the rings, and repeat the test. If the compression comes up, the rings are faulty.

Abnormally high readings on all cylinders indicate heavy carbon accumulation, a condition that might be accompanied by high pressures and noise.

**NOTE:** *In case of severe vibrations and detonation noise, have the injectors checked and overhauled by an authorized fuel injection service center. Poor fuel quality, contaminants and loss of positive fuel pressure to the injection pump will result in injector faults.*

When low compression is found, determine the cause by applying a small amount of oil in the cylinder through the glow plug hole. Allow the oil to settle.

Install the pressure gauge and repeat the above test. If the compression reading rises dramatically, the fault is with the rings. If the compression value does not rise, the problem is with the valves.

A slight rise in compression would indicate a problem with both the rings and the valves.

## DRIVE BELT ADJUSTMENT

The drive belt must be properly tensioned. A loose drive belt will not provide proper alternator charging and will eventually damage the alternator. A drive belt that is too tight will pull the alternator out of alignment and/or cause the alternator to wear out prematurely. Excessive drive belt tension can also cause rapid wear of the belt and reduce the service life of the coolant pump's bearing. A slack belt or the presence of oil on the belt can cause belt slipping, resulting in high operating temperatures and tachometer variations.

**⚠ WARNING:** *Never attempt to check or adjust the drive belt's tension while the engine is in operation.*

## Checking Belt Tension

1. To check the belt tension, press the belt at the midpoint between the alternator pulley and the crankshaft pulley with a force of 22 lbs. (10 kfg) (98 N). The belt deflection should be 3/8 in. – 1/2 in. (10 – 12 mm) deep.

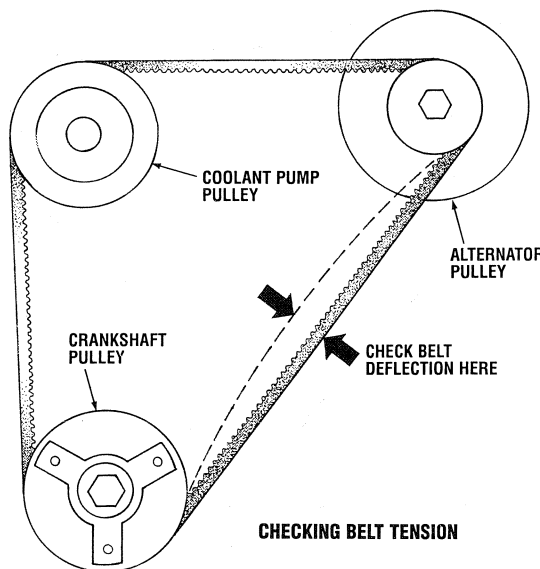

## Adjusting Belt Tension

1. To adjust the belt tension, loosen the alternator adjusting strap bolt and the base mounting bolt.
2. With the belt loose, inspect the belt for damage, wear, cracks and frayed edges. If the belt is damaged, replace it. If it is nearly worn out and deeply sunk in the pulley groove, replace it.



3. Pivot the alternator on the base mounting bolt to the left or right as required, to loosen or tighten.
4. Tighten the base mounting bolt and the adjusting strap bolt securely.
5. Run the engine for about 5 minutes, then shut down and recheck the belt tension.

# ENGINE ADJUSTMENTS

**NOTE:** UNIVERSAL recommends that the following engine adjustments be performed by a competent engine mechanic. The information below is provided to assist the mechanic.

## IDLE SPEED ADJUSTMENT & TACHOMETER CHECK (New Installation)

### Checking the Idle Speed

Use a photoelectric-type tachometer to check the idle speed.

**NOTE:** In a new installation having new instrument panels, the tachometer may not always be correctly calibrated to the engine's rpm. This calibration should be checked in all new installations.

1. Warm up the engine to normal operating temperature. Remove any specks on the crankshaft pulley with a clean cloth and place a piece of suitable reflecting tape on the pulley to facilitate the use of the tachometer.
2. Start and idle the engine.
3. Aim the light of the tachometer onto the reflecting tape to confirm the engine speed. Check the instrument panel tachometer reading. Adjust the tachometer in the panel by using the instrument calibration pod as needed to bring the instrument panel tachometer into the same rpm reading as the engine.
4. Adjust the idle speed if the engine speed is not within the specified value.

### Normal idle speed:

Model M-25XPB: 1000 – 1200 rpm

Model M-35B: 800 – 1000 rpm

Model M-40B: 800 – 1000 rpm

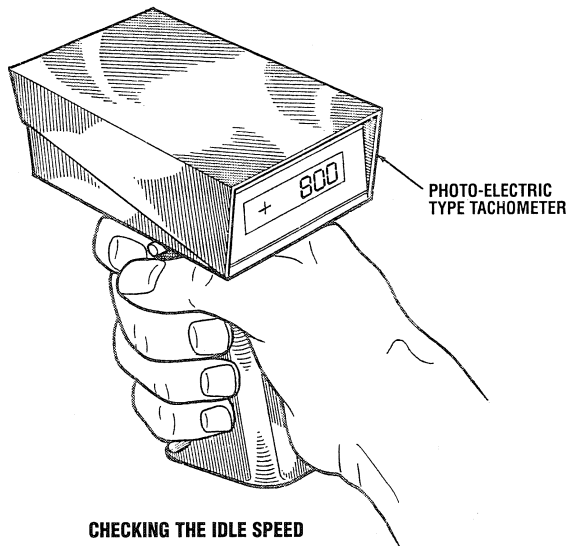

### Adjusting the Idle Speed

1. Loosen the locknut on the idle adjustment bolt on the fuel injection pump.
2. Turn the idle adjustment bolt until the idling speed is within the standard range. The idle speed will increase when the adjusting bolt is turned clockwise and decrease when the bolt is turned counterclockwise.
3. Tighten the locknut.
4. Race the engine several times to ensure the idle speed remains as set.

**NOTE:** Should the engine rpm be in question, verify the tachometer readings as shown at the instrument panel with a mechanical or strobe-type tachometer at the engine crankshaft.

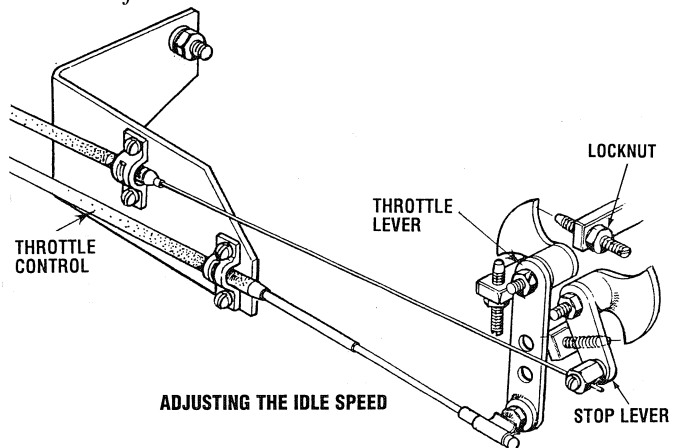

# EXHAUST MANIFOLD SERVICE

## EXHAUST MANIFOLD

The exhaust manifold, which was disassembled from the cylinder head, should be inspected before reassembly.

1. Remove the exhaust nipples, elbows and plugs from the manifold.
2. Examine all parts for defects, corrosion and wear, and replace as needed.
3. Flush out the manifold's interior with a liquid cleaner and rinse thoroughly with fresh water.
4. Use a pipe cleaner to clear the passage that connects the filler neck to the coolant recovery tank tubing.
5. Flush out the coolant recovery tank and its connecting tube.

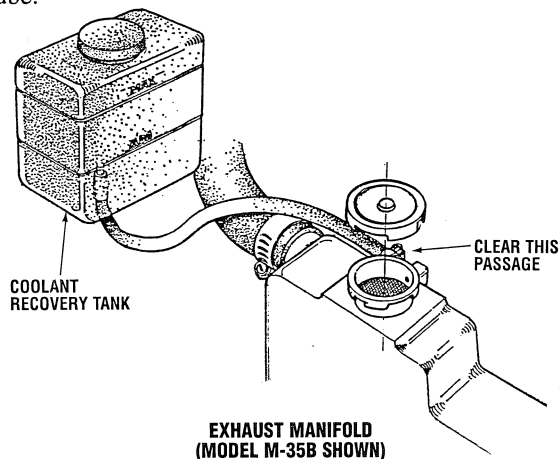

## ASSEMBLY

1. If the manifold was removed as an assembly and left intact, it can be replaced on the cylinder head in the reverse order of removal.

Do not reuse the gaskets; install new ones.

- a. Loosely attach the manifold elbows to the cylinder head using new gaskets. Do not use any gasket sealant on these gaskets.
  - b. Gradually tighten each fitting to ensure proper alignment of all the parts. This should be done in three steps.
2. Reinstall the exhaust connections. Use new gaskets and check the exhaust elbow-to-manifold clamp's condition. Replace it if necessary.
  3. Check the manifold pressure cap. Open the valve by pulling it, and make sure it closes when released. Make certain the upper and lower seals are in good condition. If any doubt, replace the cap.

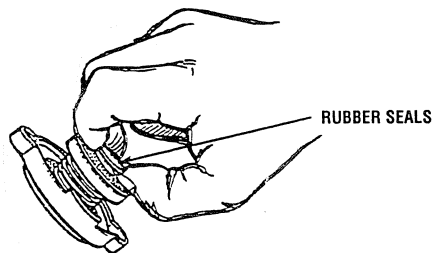

CHECKING THE PRESSURE CAP

# LUBRICATION SYSTEM DESCRIPTION

## DESCRIPTION

The lubricating system consists of an oil strainer, oil pump, relief valve, oil filter and oil pressure switch.

The oil pump draws lubricating oil from the oil sump through the oil strainer to the oil filter. Then the oil is delivered under pressure to the crankshaft, connecting rods, idler gear, governor shaft, camshaft and rocker arm shaft through oil galleries in the engine block.

Some of the oil that lubricates these components or is splashed by the crankshaft also reaches and lubricates the pistons, cylinders, small ends of the connecting rods, tappets, pushrods, intake and exhaust valves, and timing gears. The oil then returns to the oil sump to repeat the continuous cycle. When the oil pressure exceeds the specified pressure, the oil pushes open the relief valve in the oil pump and returns to the oil sump, keeping the oil pressure within its specified range.

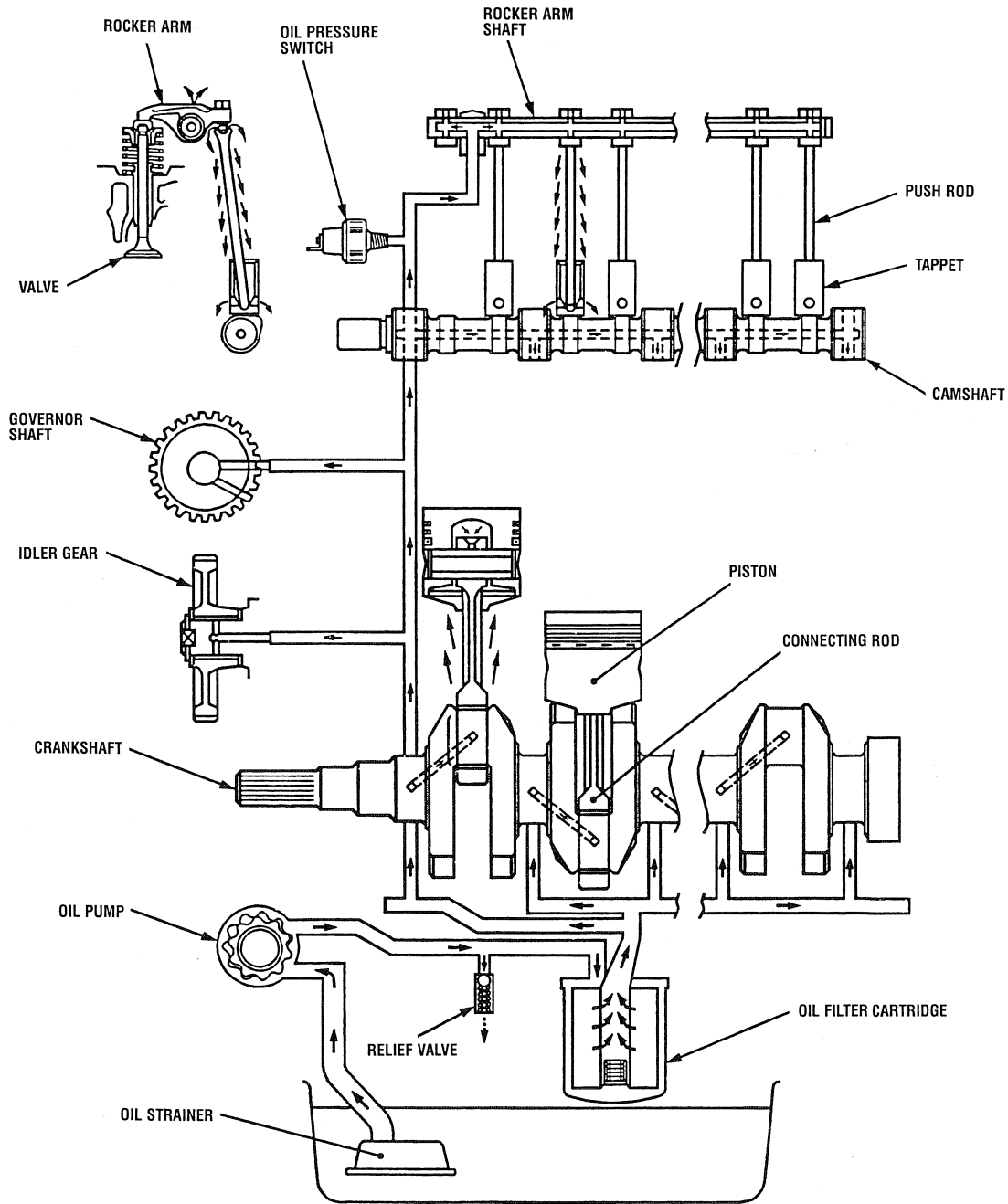

LUBRICATION SYSTEM

# LUBRICATION SYSTEM DESCRIPTION

## OIL PUMP

The oil pump is a trochoid type pump. Inside the pump body, the 10-lobe inner rotor is eccentrically engaged with the 11-lobe outer rotor. The inner rotor is driven by the crankshaft, which in turn rotates the outer rotor.

When the inner rotor rotates, the outer rotor also rotates in the same direction. Since the two rotors have different centers and different numbers of lobes, spaces are generated between the lobes as shown in the illustration.

At position **A**, there is little space between lobes in the inlet port. As the rotor rotates towards position **B**, the space between the lobes becomes larger, creating a negative pressure which draws in oil.

Outside the inlet port, as shown in position **B**, the space between the lobes becomes gradually smaller, and oil pressure increases. At position **C**, oil is discharged from the outlet port.

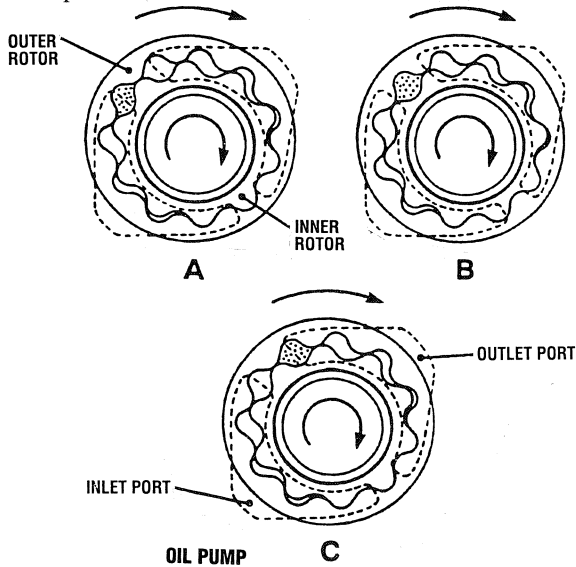

## RELIEF VALVE

The relief valve prevents damage to the lubrication system due to high oil pressure. This relief valve is a ball-type direct acting relief valve, and is best suited for low pressures. When oil pressure exceeds the upper limit, the ball is pushed back by the oil pressure, and the oil escapes.

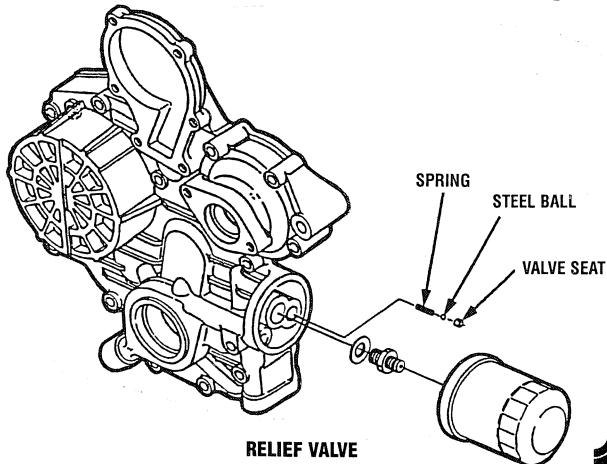

## OIL FILTER

Impurities in engine oil can cause wear and components to seize as well as impairing the physical and chemical properties of the oil itself. Impurities contained in force-fed engine oil are absorbed as they pass through the filter element.

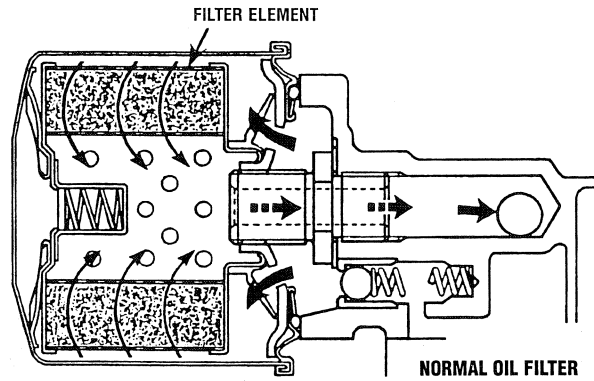

When the filter element is clogged and the oil pressure in the inlet line builds up by 14 psi (1.0 kgf/cm<sup>2</sup>) (98 kPa) more than the outlet line, the bypass valve opens and the oil flows from the inlet to the outlet, bypassing the filter element.

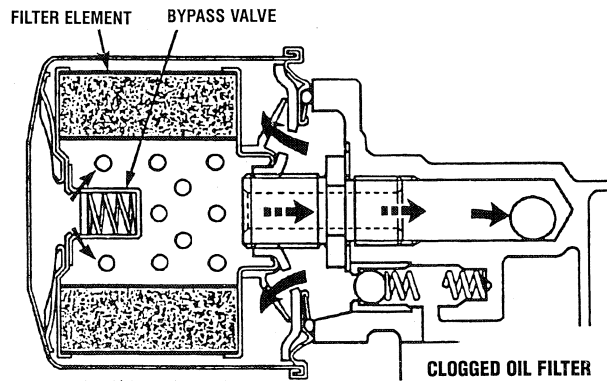

## OIL PRESSURE SWITCH

The oil pressure switch is mounted on the cylinder block, to warn the operator that the lubricating oil pressure is low. If the oil pressure falls below 7 psi (0.5 kgf/cm<sup>2</sup>) (49 kPa), the oil warning light will go on, alerting the operator. If this happens, stop the engine immediately and check the cause of the oil pressure drop.

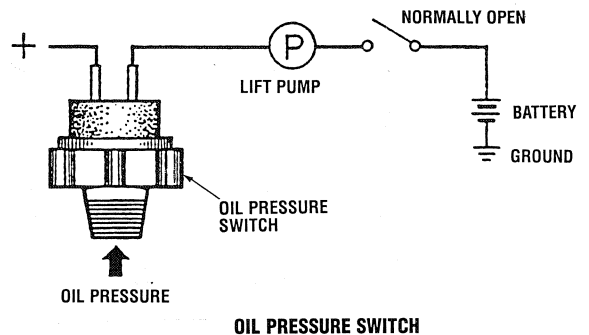

# LUBRICATION SYSTEM SERVICE

## OIL PRESSURE

The engine's oil pressure, during operation, is indicated by the oil pressure gauge on the instrument panel. During normal operation, the oil pressure will range between 40 and 60 psi (2.8 and 4.2 kg/cm<sup>2</sup>).

**NOTE:** A newly started, cold engine can have an oil pressure reading up to 60 psi (4.2 kg/cm<sup>2</sup>). A warmed engine can have an oil pressure reading as low as 35 psi (2.5 kg/cm<sup>2</sup>). These readings will vary depending upon the temperature of the engine and the rpms.

## Low Oil Pressure

The specified safe minimum oil pressure is 5 – 10 psi. A gradual loss of oil pressure usually indicates worn bearings. For additional information on low oil pressure readings, see *ENGINE TROUBLESHOOTING*.

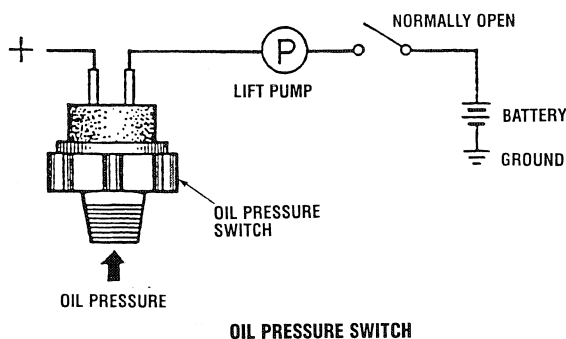

## Checking the Oil Pressure

1. Remove the oil pressure switch and install a mechanical oil pressure gauge in its place.
2. Start the engine. After warming up to operating temperature, measure the oil pressure at both idling and rated speeds.
3. If the oil pressure is less than the specified limit, check the following:
  - a. Engine oil insufficient.
  - b. Oil pump defective.
  - c. Oil strainer clogged.
  - d. Oil filter.
  - e. Oil gallery clogged.
  - f. Excessive oil clearance of bearing.
  - g. Foreign matter in the relief valve.

### When Reassembling:

1. After checking the engine oil pressure, tighten the engine oil pressure switch to the specified torque.

**Oil pressure at idle speed:**  
15 psi (1.05 kg/cm<sup>2</sup>) (103.4 kPa)

**Oil pressure at rated speed:**  
40 – 60 psi (2.8 – 4.2 kg/cm<sup>2</sup>) (276 – 414 kPa)

**Oil pressure switch torque:**  
10.8 – 14.5 ft-lb (1.5 – 2.0 kg-m)

## Oil Pressure Switch Oil Pressure Sender (optional)

When performing an engine overhaul, replace the oil pressure switch, and the oil pressure sender if used.

When installing the new parts, apply teflon sealant to the threaded ends being careful not to close off the oil hole in the sender.

**Oil pressure switch torque:**  
10.8 – 14.5 ft-lb (1.5 – 2.0 kg-m)

**CAUTION:** Oil Pressure Switch – Do not use lock pliers, vise grips, or pipe wrenches on the oil pressure switch. Use the correct socket which is available from Snap-On, Proto, New Britain and others. Damage to the switch will cause oil leaks and/or switch failure.

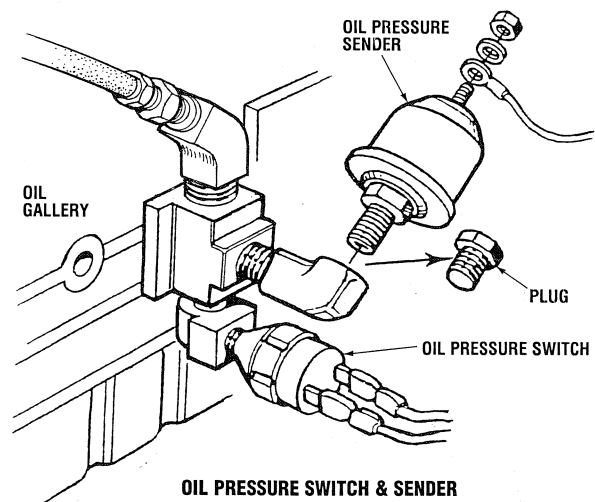

## OIL PUMP

### Rotor Lobe Clearance

1. Measure the clearance between the lobes of the inner rotor and the outer rotor with a feeler gauge.
2. If the clearance exceeds the standard value, replace the oil pump rotor assembly.

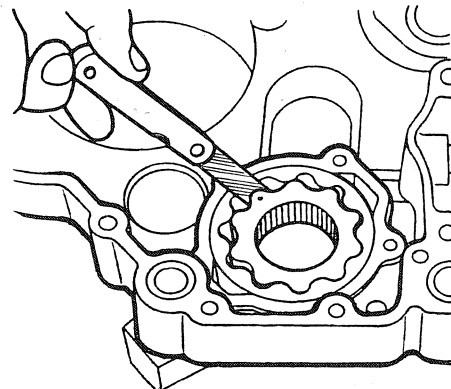



# LUBRICATION SYSTEM SERVICE

## Clearance Between Outer Rotor and Pump Body

1. Measure the clearance between the outer rotor and the pump body with a feeler gauge.
2. If the clearance exceeds the standard value, replace the oil pump rotor assembly.

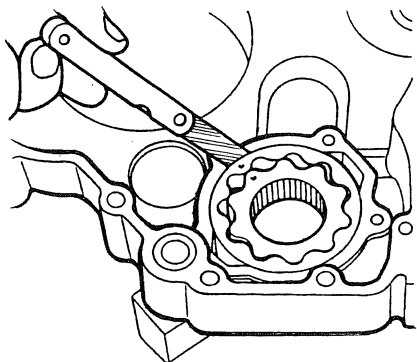

## Clearance Between Rotor and Cover

1. Put a strip of plastigauge onto the rotor face with grease.
2. Install the cover and tighten the screws.
3. Remove the cover carefully, measure the amount of the flattening with the scale, and get the clearance.
4. If the clearance exceeds the standard value, replace the oil pump rotor assembly.

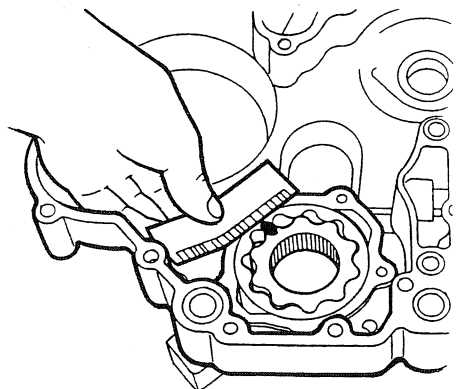

# COOLING SYSTEM DESCRIPTION

## DESCRIPTION

The engine is cooled by a closed fresh water coolant circuit. The coolant is circulated by a belt-driven impeller pump. The coolant temperature is thermostatically controlled.

Raw water is pumped by gear-driven impeller pump through an engine-mounted heat exchanger to cool the engine coolant. The raw water then enters the water-injected exhaust elbow where it mixes with and cools the exhaust gasses. This mixture then discharges overboard.

## COOLANT PUMP

The coolant pump is a centrifugal-type metal impeller pump mounted on the front of the engine. It is driven from the crankshaft by a V-belt.

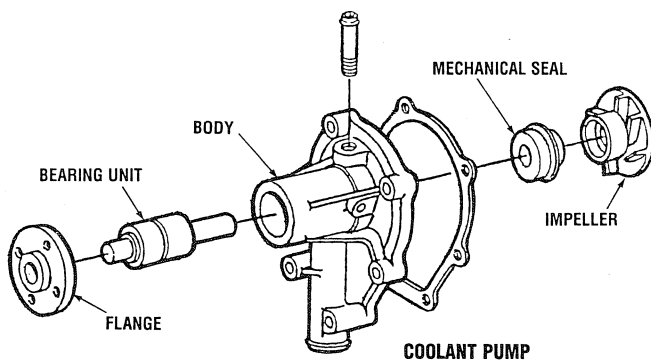

## THERMOSTAT

A thermostat, located near the manifold at the front of the engine, controls the coolant temperature as it continuously flows through the closed cooling circuit.

The thermostat is a wax pellet type thermostat. Wax is enclosed in the pellet. The wax is solid at low temperatures, but turns liquid at high temperatures, expands and opens the valve.

When the engine is first started, the closed thermostat prevents coolant from flowing (some coolant is by-passed through a hole in the thermostat to prevent the exhaust manifold from overheating). As the engine warms up, the thermostat gradually opens. The thermostat is accessible and can be checked, cleaned, or replaced easily.

## WATER TEMPERATURE SWITCH

The water temperature switch is located on the thermostat housing (see illustration). This switch is normally open. When activated, it will close and sound an alarm.

## WATER TEMPERATURE SENDER (Optional)

The water temperature sender (if supplied) is located on the thermostat housing (see illustration). It is a variable resistor affected by heat. Voltage from the water temperature gauge is grounded through the sender to the block. Depending on the resistance through the sender affected by coolant heat, the gauge will indicate a temperature reading.

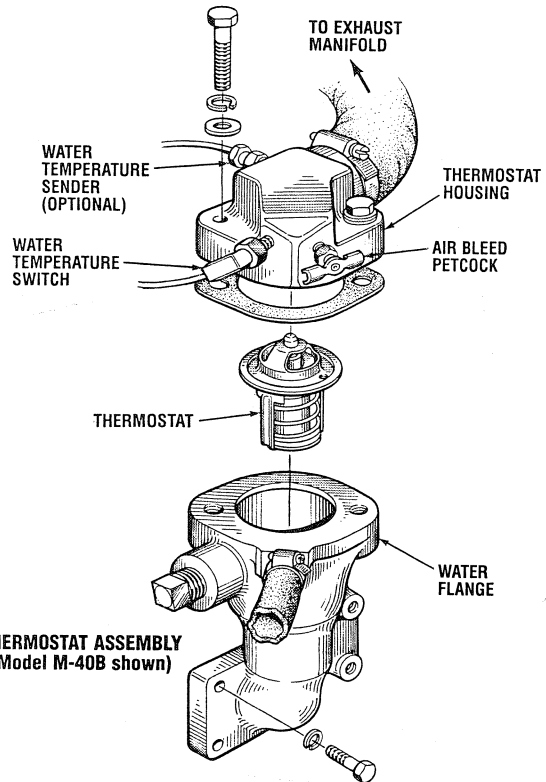

## RAW WATER PUMP

The raw water pump is a gear driven, positive displacement, self-priming rotary pump with a non-ferrous housing and a neoprene impeller. The impeller has flexible vanes which wipe against a curved cam plate within the impeller housing, producing the pumping action. On no account should this pump be run dry as water acts as a lubricant for the impeller. There should always be a spare impeller and impeller cover gasket aboard (an impeller kit). Raw water pump impeller failures occur when lubricant (raw water) is not present during engine operation. Such failures are not warrantable, and operators are cautioned to make sure raw water flow is present at start-up.

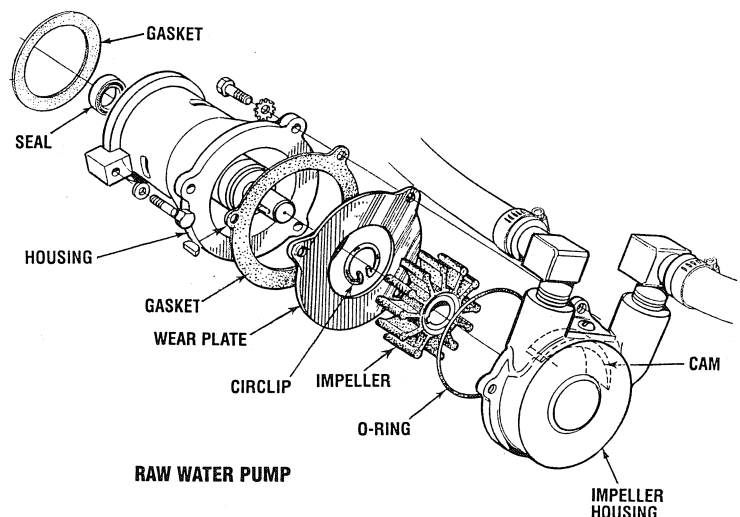

# COOLING SYSTEM DESCRIPTION

## COOLANT RECOVERY TANK

A coolant recovery tank allows for engine coolant expansion and contraction during engine operation, without any significant loss of coolant and without introducing air into the cooling system. This tank is best located at or above the engine manifold level, and should be easily accessible.

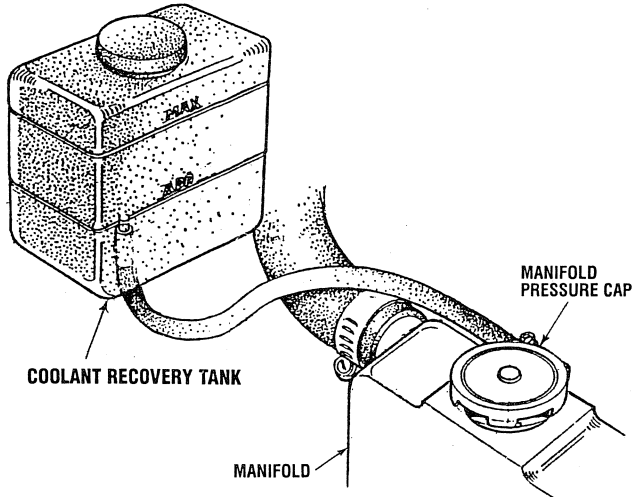

## ZINC ANODE

A zinc anode or "pencil", is located in the raw water cooling circuit within the heat exchanger. The purpose of the zinc anode is to sacrifice itself to electrolysis action taking place in the raw water cooling circuit, thereby reducing the effects of electrolysis on other components of the system. The condition of the zinc anode should be checked monthly and the anode cleaned or replaced, as required. Spare anodes should be carried onboard. The area in the exchanger where the anode is located should periodically be cleaned of anode debris.

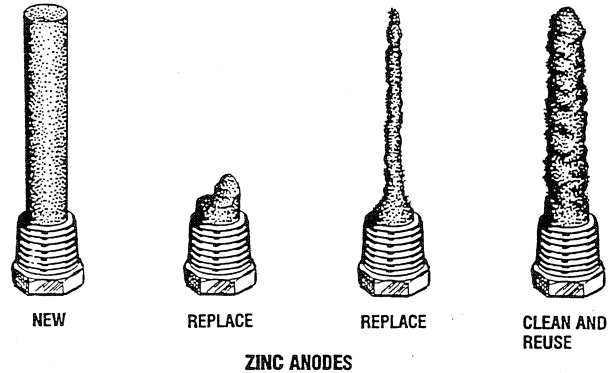

## HEAT EXCHANGER

The heat exchanger is a copper tube which encloses a number of small copper tubes. Raw water is pumped through the small copper tubes and the freshwater coolant from the engine is circulated around the copper tubes. The raw water removes heat from the freshwater coolant. To keep the heat exchanger operating efficiently, it should be removed from the engine every 1000 hours to be thoroughly cleaned and pressure tested.

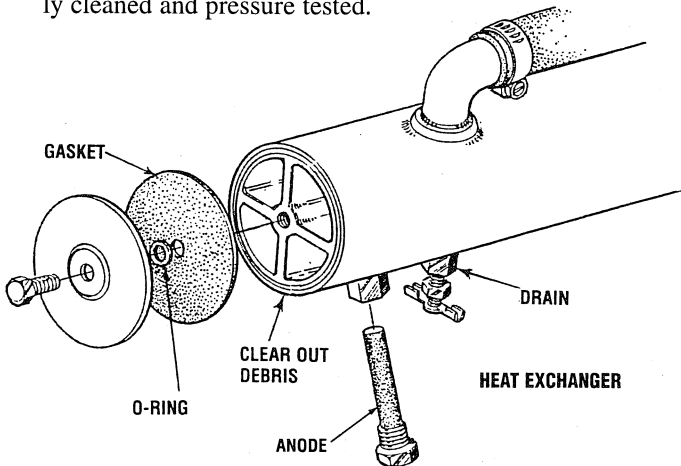

# COOLING SYSTEM SERVICE

## THERMOSTAT

1. Remove the thermostat housing mounting screws, then remove the thermostat housing.
2. Remove the thermostat.

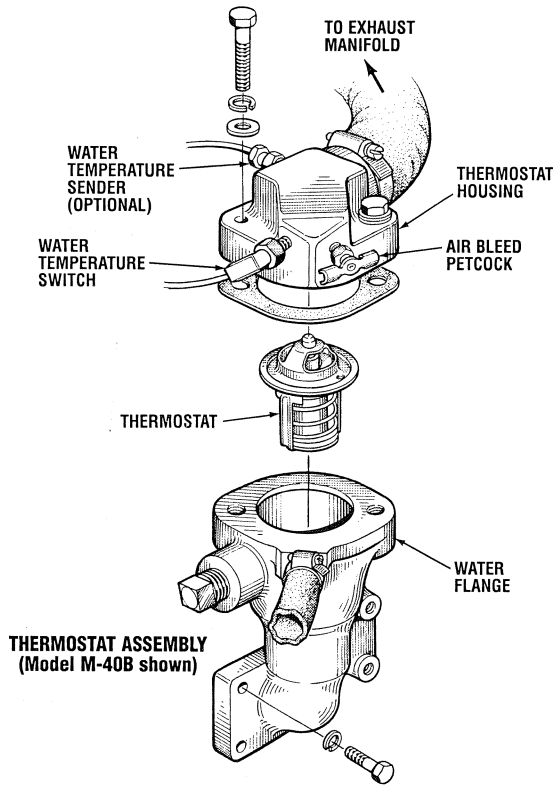

THERMOSTAT ASSEMBLY  
(Model M-40B shown)

3. Visually check the thermostat for damage. Then put it in water and raise the water temperature to test its valve opening temperature as described below. Replace if defective.

**CAUTION:** The wax pellet-type thermostat remains closed if its heat-sensing part is defective. Leaving this uncorrected would cause the engine to overheat.

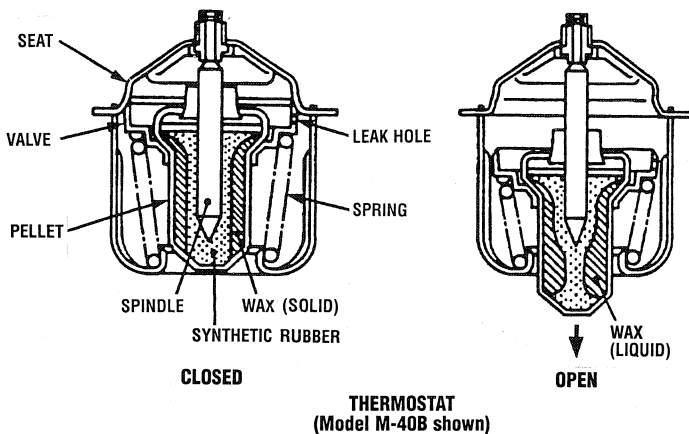

THERMOSTAT  
(Model M-40B shown)

## Checking the Thermostat Valve Opening Temperature

1. Push down the thermostat valve and insert a string between the valve and the valve seat.
2. Place the thermostat and a thermometer in a container with water and gradually heat the water.
3. Hold the string to suspend the thermostat in the water. When the water temperature rises, the thermostat valve will open, allowing it to fall down from the string. Read the temperature at this moment on the thermometer.
4. Continue heating the water and read the temperature when the valve has completely opened [about 0.236 in. (6 mm)].
5. If these temperatures are not within the standard values as shown in the chart below, replace the thermostat.

	STANDARD VALUE
Thermostat's valve opening temperature	157.1 – 162.5° F (69.5 – 72.5° C)
Temperature at which thermostat completely opens	185° F (85° C)

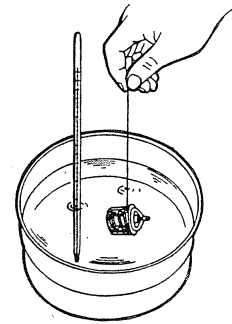

### When Reassembling:

Apply a liquid gasket (*Three Bond 1215* or equivalent) only at the thermostat cover side of the gasket.

## CHANGING THE RAW WATER IMPELLER

1. Close the raw water intake.
2. Remove the inlet and outlet port hoses from the pump, noting the port location and positioning.
3. Remove the pump assembly and its gasket from the engine.
4. Remove the three hex head screws that hold the housing to the cover.
5. Tap the housing/cover assembly on its side to loosen and separate the cover from its housing.
6. Remove the cover and its O-ring and remove the impeller gasket and plate.
7. Remove the retaining ring (circlip) and pry out the impeller. Take care not to lose the key off the shaft's keyway.

# COOLING SYSTEM SERVICE

**CAUTION:** *If any of the vanes have broken off the impeller they must be found to prevent blockage in the cooling circuit. They often can be found in the heat exchanger.*

8. Replace the gasket, impeller, and O-ring.
  9. Apply a film of petroleum jelly or silicon to the inner surface of the impeller housing.
- NOTE:** *Just coat the surface; do not over apply.*
10. Install the cover housing over the impeller.
  11. Install the three hex screws and tighten.
  12. Mount the pump to the engine taking care that the end seal and gasket are in place. Do not tighten the pump mounting screws, just finger tight.
  13. Reassemble the hose connections and open the raw water intake.
  14. Start the engine in idle; this will allow the pump to align itself with its drive shaft.
  15. Stop the engine and tighten the pump assembly mounting screws.
  16. Start and run the engine, check for leaks and check for a normal operating temperature.

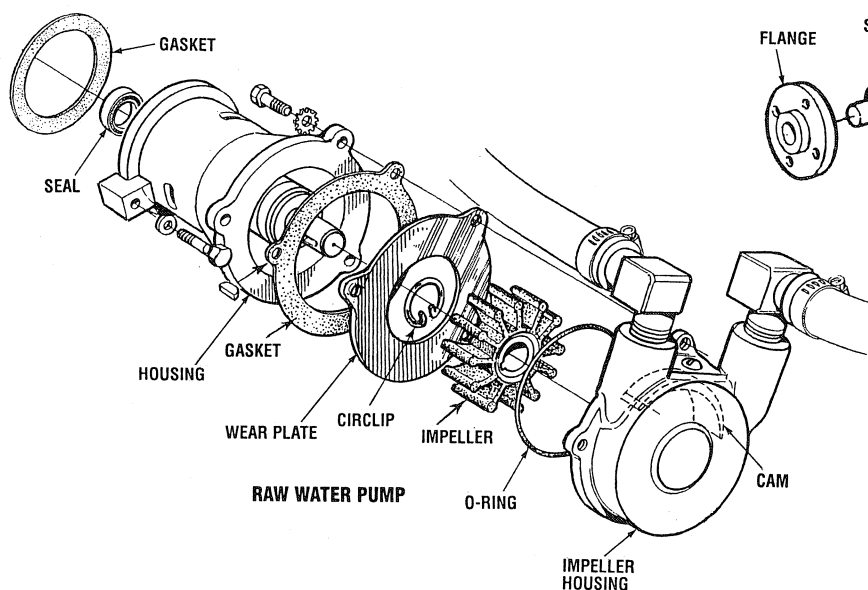

## COOLANT PUMP

1. Loosen the alternator mounting bolts, and remove the drive belt.
2. Remove the coolant pump pulley.
3. Remove the coolant pump assembly from the gear case cover.
4. Remove the flange.
5. Press out the shaft with the impeller on it.
6. Remove the impeller from the shaft.
7. Remove the mechanical seal assembly.
8. Check every part for cracks, damage and water leaks. Replace any parts that are defective.

**NOTE:** *No rebuilding kits are available for the antifreeze circulating pump, however individual parts are available to allow the pump to be rebuilt.*

9. Check the impeller and shaft for rotating condition. If they make a noise or rotate irregularly, replace as an assembly.

### When Reassembling:

1. Apply a liquid gasket (three Bond 1215 or equivalent) to both sides of the gasket.
2. Replace the mechanical seal with a new one.

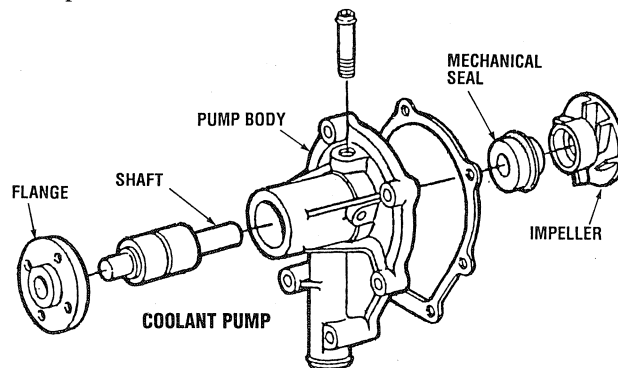

# FUEL SYSTEM DESCRIPTION

## DESCRIPTION

An electromagnetic fuel lift pump draws fuel from the fuel tank through an owner-supplied fuel filter/water separator to remove impurities such as dirt and water. The lift pump then pumps the fuel through the engine's primary fuel filter to the fuel injection pump. The fuel is pressurized by the fuel injection pump to the opening pressure of the injection nozzles [1991 – 2133 psi (140 – 150 kgf/cm<sup>2</sup>) (13.73 – 14.71 MPa)] and injected into the combustion chamber.

Some of the fuel that is fed to the injection nozzles lubricates the plungers inside the nozzles. Excess fuel from the

fuel injectors is returned from the nozzle holders through fuel lines to the fuel injection pump and the fuel tank.

**NOTE:** Fuel supplied to the fuel lift pump must be filtered to 10 – 25 microns or smaller by the (owner-supplied) fuel filter/water separator.

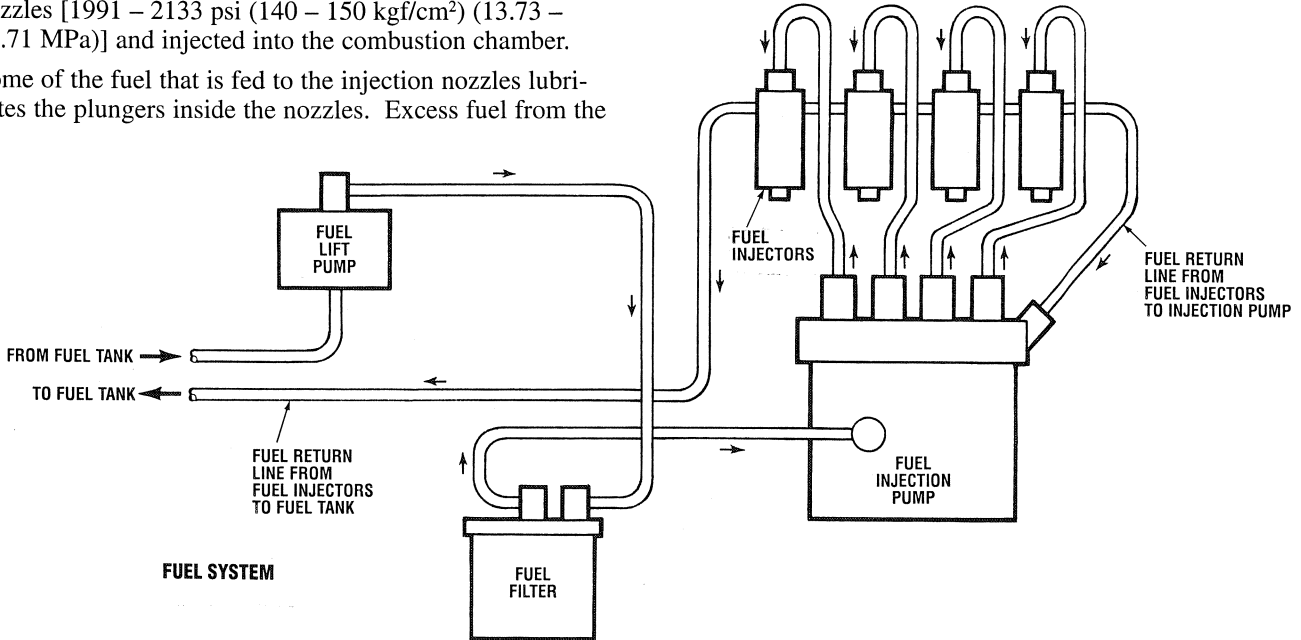

## INJECTION PUMP

The fuel injection pump is a Bosch MD type mini pump. It is small, lightweight and easy to handle.

The plunger with a left-hand lead reciprocates via the tappet roller by means of the fuel camshaft, causing the fuel to be delivered into the injection nozzle.

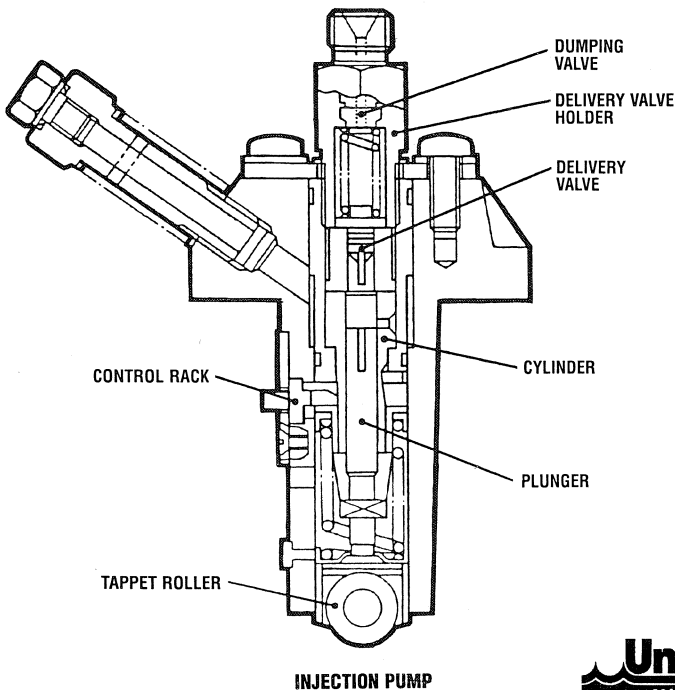

## Pump Element

The pump element consists of the plunger and the cylinder. The sliding surfaces are super-precision machined to maintain injection pressures at low engine speeds. The plunger is machined to have a slot and a control groove. Since the driving face on the plunger fits in the control sleeve, the plunger is rotated by the movement of the control rack to increase or decrease the fuel delivery.

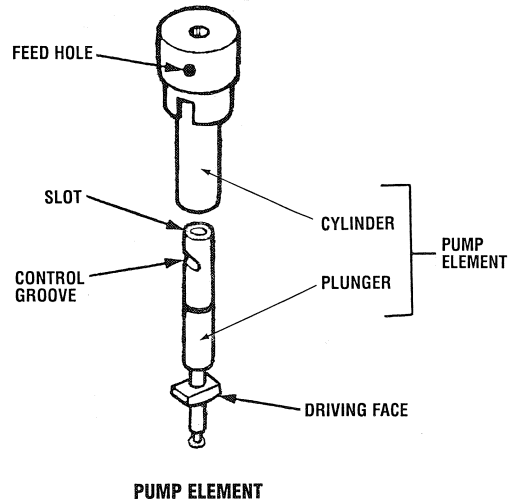

# FUEL SYSTEM DESCRIPTION

## Delivery Valve

The delivery valve consists of the valve and valve seat. The delivery valve performs the following functions:

### 1. Reverse Flow Preventing Function

If the fuel flow should reverse from the injection nozzle side when the plunger lowers, the time lag between the next delivery start and the nozzle injection start would increase. This is avoided by the delivery valve, which prevents the fuel flow from the delivery chamber to the injection line from reversing. This keeps the nozzle and the fuel line filled with fuel to maintain the prime.

### 2. Draw-Back Function

After completing the fuel delivery, the delivery valve lowers and the relief plunger end contacts the delivery valve seat. The valve further lowers until it seats firmly in the delivery valve seat. During this time, the amount of fuel corresponding to "A" is drawn back from inside the injection line, and the pressure inside the pipe is reduced, thus leading to an improved injection shut-off and preventing after-leakage dribbling.

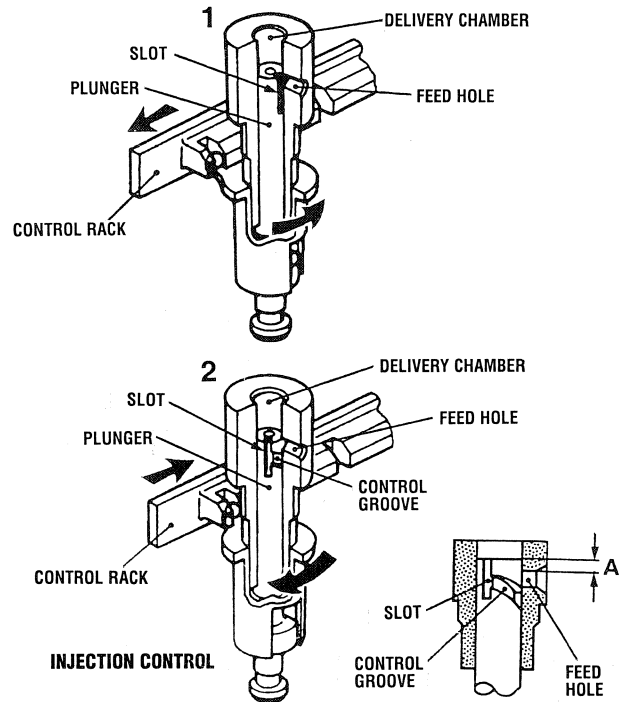
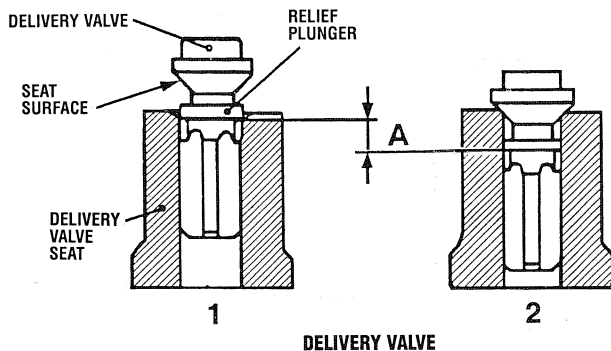

## INJECTION NOZZLE

This nozzle is a throttle-type. The needle valve is pushed against the nozzle body by the nozzle spring via the push rod. Fuel pressurized by the injection pump pushes the needle valve up, and then is injected into the pre-combustion chamber.

Excessive fuel flow passes from the nozzle holder center through the eye joint and the fuel overflow line to the fuel tank.

The injection pressure is 1991 – 2133 psi (13.73 – 14.71 MPa) (140 – 150 kgf/cm<sup>2</sup>) and is adjusted with adjusting washers.

## Injection Control

### 1. No Fuel Delivery

At the engine stop position of the control rack, the length-wise slot on the plunger aligns with the feed hole. The delivery chamber is led to the feed hole during the entire stroke of the plunger.

The pressure in the delivery chamber does not build up and no fuel can be forced to the injection nozzle.

### 2. Fuel Delivery

The plunger is rotated (see illustration) by the control rack.

When the plunger is pushed up, the feed hole is closed. The pressure in the delivery chamber builds up and force-feeds the fuel to the injection nozzle until the control groove meets the feed hole.

The amount of the fuel corresponds to the distance "A".

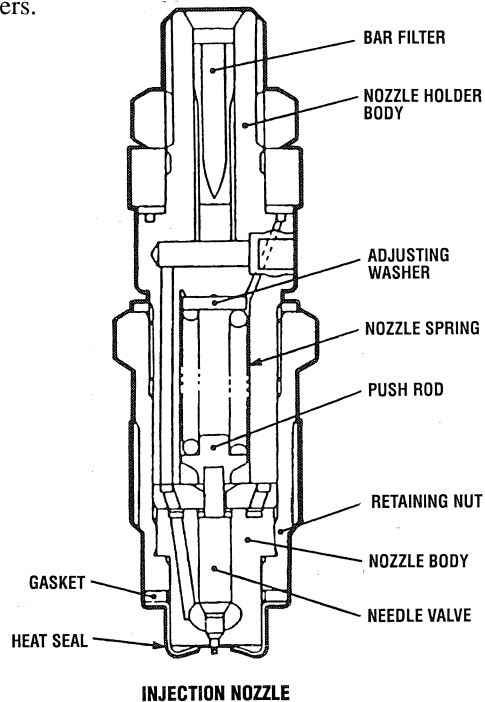

# FUEL SYSTEM DESCRIPTION

## FUEL FILTER

The fuel filter prevents dirty fuel from reaching the injection pump and the injection nozzles. Each moving part of the injection pump and nozzle is extremely precision machined, and the clearances of their sliding parts are extremely small. Fuel itself serves as lubricating oil. For this reason, it is extremely important to completely remove any water and dirt contained in the fuel.

The fuel filter cartridge will require occasional replacement to maintain an adequate flow of fuel to the injection pump. The frequency of this service will vary according to the cleanliness of the available fuel and the care used in its storage. The fuel filter eliminates any foreign matter coming from the fuel tank and protects the injection pump and injection nozzles. When fuel enters the filter, it passes from the filter element's circumference toward the center for filtering.

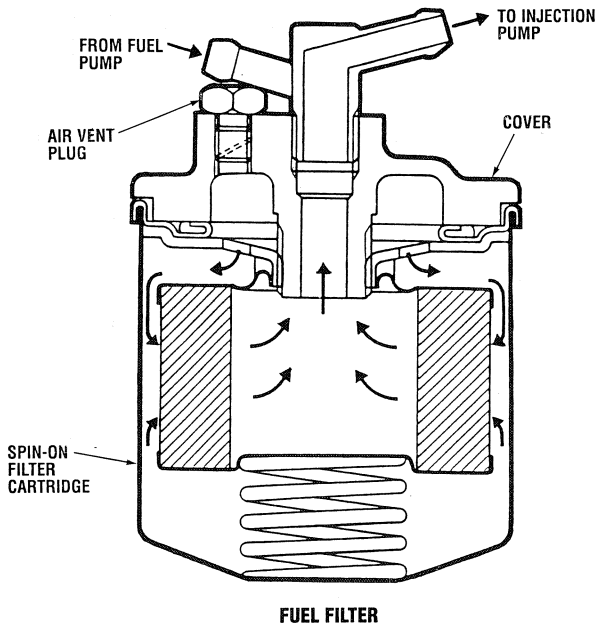

## FUEL LIFT PUMP

The on-engine fuel system is virtually self priming. Under ordinary circumstances the engine's electric fuel lift pump, which is energized by the key switch/preheat button, will supply a continuous flow of fuel from the tank. This fuel is drawn through the fuel filter/water separator to the engine lift pump, the primary spin-on fuel filter, and the injection pump.

## GOVERNOR

This mechanism maintains engine speed at a constant rate even under fluctuating loads, provides stable idling and regulates maximum engine speed by controlling the fuel injection rate.

This engine uses a mechanical governor that controls the fuel injection rate at all speed ranges (from idling to maximum speed) by utilizing the balance between the flyweight's centrifugal force and spring tension.

A governor shaft for monitoring engine speed is independent of the injection pump shaft and rotates at twice the speed of conventional types, providing better response to load fluctuation and delivering greater engine output.

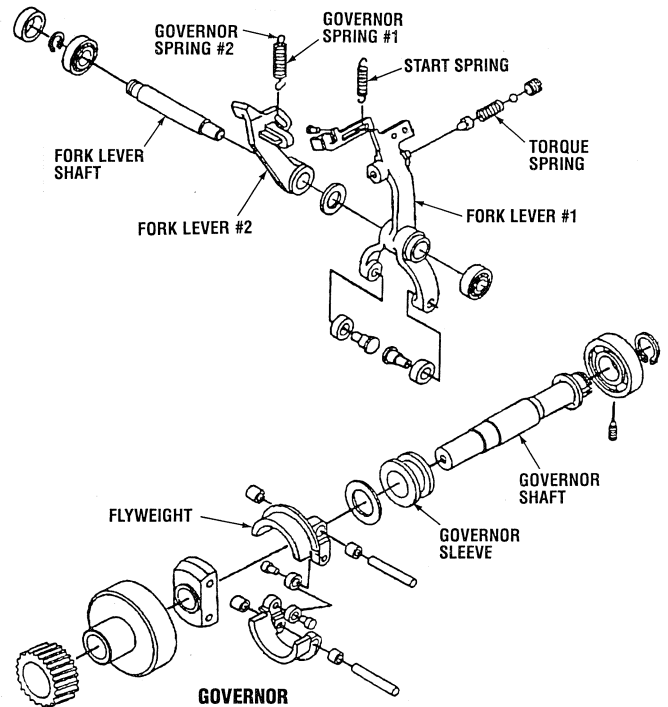

### At Start

Because no centrifugal force is applied to the flyweight, the low tension of the start spring permits the control rack to move to the starting position, supplying the amount of fuel required to start the engine.

### At Idling

Setting the speed control lever to the idling position during engine rotation permits the low tension of governor spring #2, the start spring and the idle limit spring to balance the centrifugal force of the flyweight without activating high tension governor spring #1. In this way, the fuel injection rate can be controlled to ensure stable idling.

### At High Speed Running With Overload

Governor springs #1 and #2 control the fuel injection rate. To maintain the required engine speed, fuel is supplied according to the speed control lever setting and load by balancing the tension of governor springs #1 and #2 with the centrifugal force of the flyweight.

In addition, the idle limit spring provides stable engine rotation.



# FUEL SYSTEM DESCRIPTION

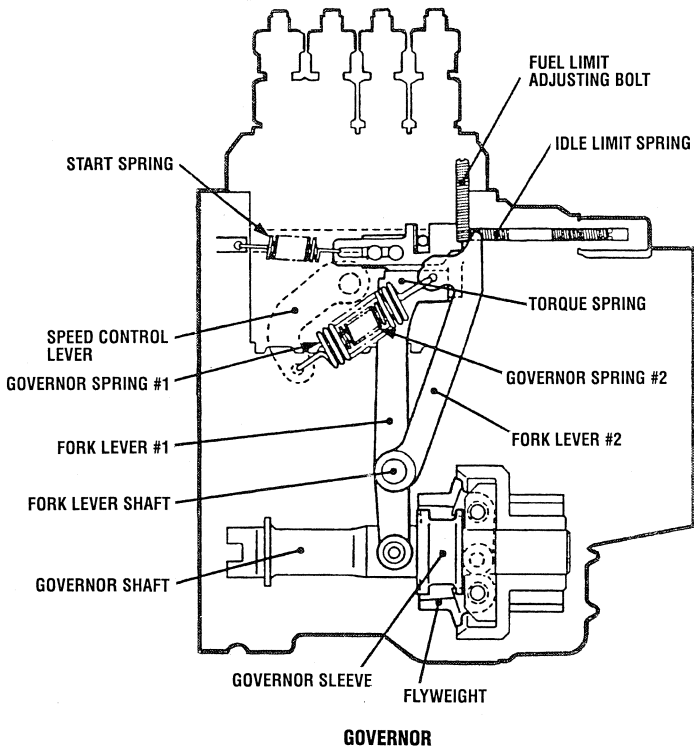

## During Overload

At load increases, the engine speed decreases, reducing the flyweight's centrifugal force. Governor springs #1 and #2, therefore, pull fork levers #1 and #2, increasing the fuel injection rate and maintaining engine speed.

If engine speed decreases due to a further increase in load, fork lever #2 will come in contact with the fuel limit bolt, stopping a further increase in the fuel injection rate.

The torque spring incorporated in fork lever #1 moves the lever in the direction of a fuel injection rate increase, thereby boosting torque and providing greater engine output.

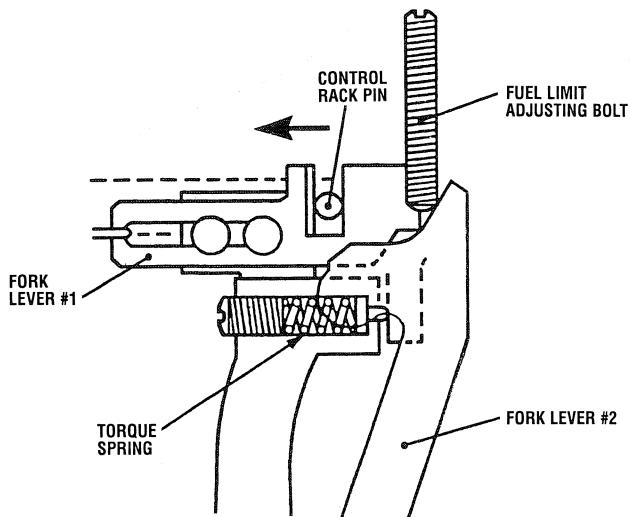

## During Low-Speed Travel

Because the centrifugal force applied to the flyweight is small, spring force presses the flyweight inward, permitting the driving bolt to come in contact with the flyweight at the position shown in the illustration.

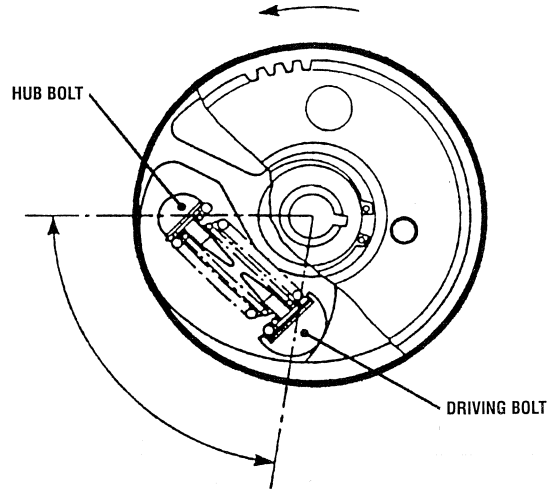

## During Medium to High Speed Travel

As the engine speed increases, the centrifugal force applied to the flyweight increases, expanding it around the hub bolt in the direction of the arrow, thereby rotating the position (where the driving bolt is in contact with the flyweight) through angle  $\theta$  as shown in the illustration.

Therefore, since the fuel camshaft rotates from the injection pump gear in the rotational direction through angle  $\theta$ , injection timing is advanced.

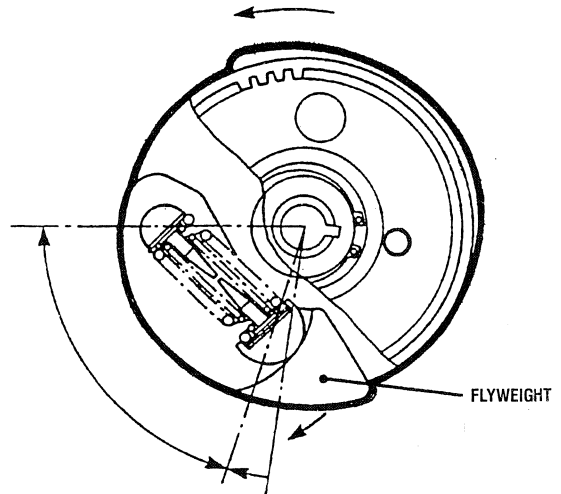

# FUEL SYSTEM DISASSEMBLY & REASSEMBLY

**WARNING:** Do not allow smoking or open flames near the fuel system when servicing. Also provide proper ventilation.

## INJECTION PUMP

If replacing the pump element, the amount of fuel injection should be bench tested and adjusted.

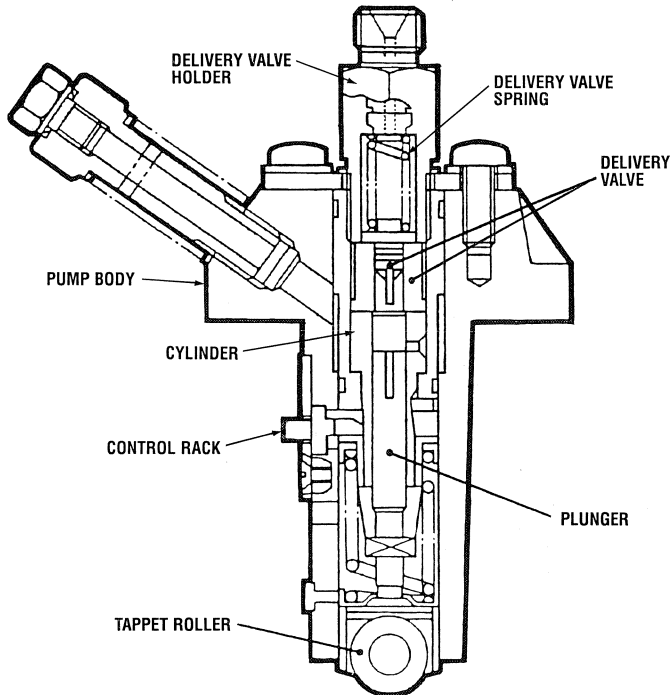

INJECTION PUMP

## INJECTION NOZZLE

### Nozzle Holder

1. Secure the nozzle retaining nut in a vise.
2. Remove the nozzle holder, and take out the parts inside the nozzle holder.

### When Reassembling:

1. Assemble the nozzle in clean fuel oil.
2. Install the push rod, noting its direction.
3. After assembling the nozzle, be sure to adjust the fuel injection pressure.

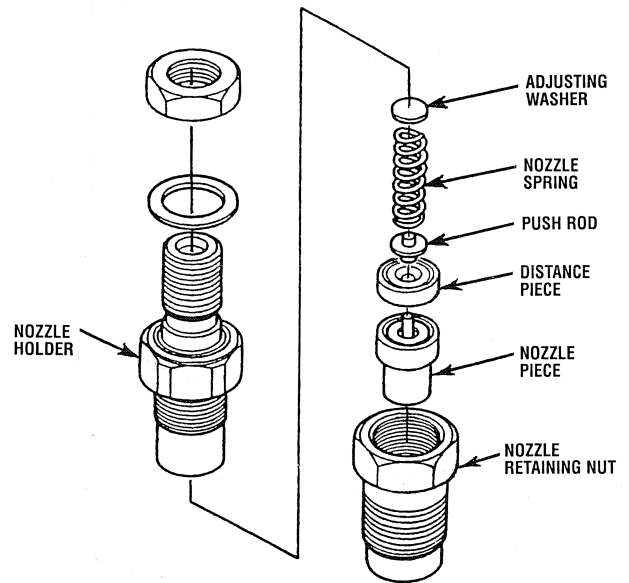

INJECTION NOZZLE

# FUEL SYSTEM SERVICE

## INJECTION PUMP

### Injection Timing

1. Remove the injection lines.
2. Remove the injection pump side cover, push in the control rack of the injection pump by 0.2 in. (5 mm) and hold it at that position.

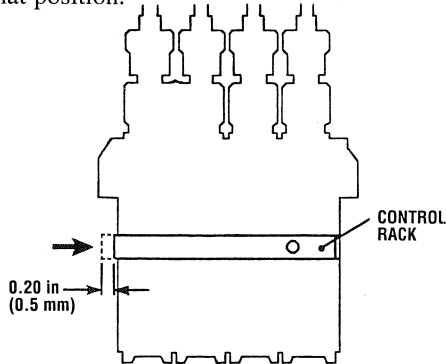

3. Turn the flywheel counterclockwise until fuel flows from the delivery valve holder.
4. Continue to turn the flywheel slowly, and stop it as soon as the fuel level at the tip of the delivery valve holder begins to increase.
5. Check to see if the "FI" mark (or the timing angle lines on the flywheel) is aligned with the punch mark.

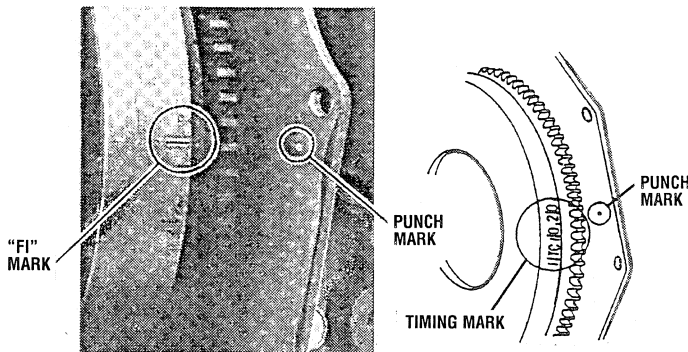

6. If the timing is out of adjustment, readjust the timing with shims.

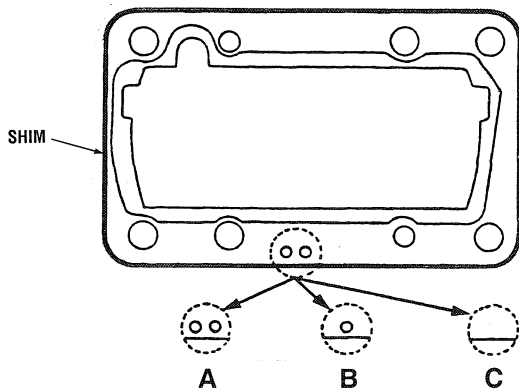

Shim A (Two holes): 0.0079 in. (0.20 mm)  
 Shim B (One hole): 0.0098 in. (0.25 mm)  
 Shim C (Without a hole): 0.0118 in. (0.30 mm)

### Shim Specifications – up to Engine Serial Number 489290.

1. Shims are available in thicknesses of 0.0059 in. (0.15 mm) and 0.0118 in. (0.30 mm). Combine these shims for adjustments.
2. The addition or reduction of a shim 0.0059 in. (0.15 mm) delays or advances the injection timing by approx. 1.5° (0.026 rad.).
3. After adjusting the injection timing, apply a liquid-type gasket (*Three Bond 1215* or equivalent) to both sides of the injection pump shim before reassembling.

### Shim Specifications – Engine Serial Number 489291 on up.

1. The sealant is applied to both sides of the soft metal gasket shim. The liquid gasket is not required for assembling.
2. Shims are available in thicknesses of 0.0079 in. (0.20 mm), 0.0098 in. (0.25 mm) and 0.0118 in. (0.30 mm). Combine these shims for adjustments.
3. The addition or reduction of a shim 0.0020 in. (0.05 mm) delays or advances the injection timing by approx. 0.5° (0.0087 rad.).
4. In disassembling and replacing, be sure to use the same number of new gasket shims with the same thicknesses.

### Fuel Tightness of Pump Element

1. Remove the fuel injection lines and glow plugs.
2. Install the injection pump pressure tester to the injection pump.
3. Set the speed control lever to the maximum speed position.
4. Turn the flywheel ten times or more to increase the pressure.
5. If the pressure cannot reach the limit, replace the pump element or injection pump assembly.

**NOTE:** Apply a liquid gasket (*Three Bond 1215* or equivalent) to both sides of the solenoid cover gasket.

### Fuel Tightness of Delivery Valve

1. Remove the fuel injection lines and glow plugs.
2. Set a pressure tester onto the fuel injection pump.
3. Turn the flywheel and raise the pressure to approx. 2133 psi (150 kgf/cm<sup>2</sup>) (14.7 MPa).
4. Now turn the flywheel back about half a turn (to keep the plunger free). Maintain the flywheel at this position and measure the time taken for the pressure to drop from 2133 to 1990 psi (150 to 140 kgf/cm<sup>2</sup>) (14.7 to 13.7 MPa).

If the measurement is less than the limit, replace the delivery valve.

**NOTE:** Apply a liquid gasket (*Three Bond 1215* or equivalent) to both sides of the solenoid cover gasket.

# FUEL SYSTEM SERVICE

## FUEL INJECTORS

**CAUTION:** *The spray nozzle velocity is such that it may penetrate deeply into the skin of the fingers and hands, destroying tissue. If it enters the bloodstream, it may cause blood poisoning.*

### Nozzle Injection Pressure

1. Install the injection nozzle to the nozzle tester.
2. Slowly move the tester handle to measure the pressure at which fuel begins jetting out from the nozzle.

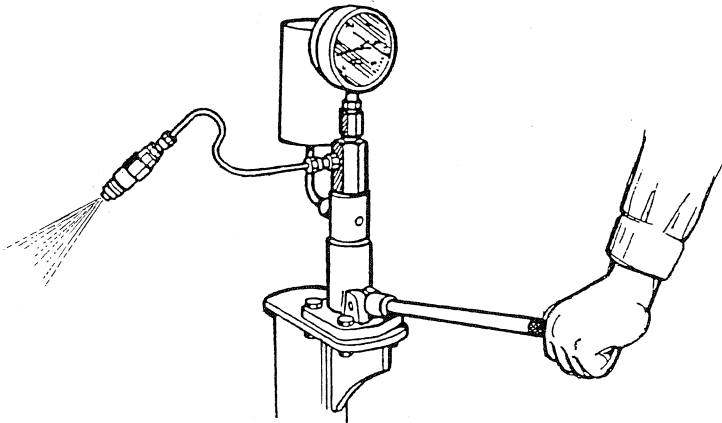

3. If the measurement is not within the standard value, disassemble the injection nozzle and change the adjusting washer until the proper injection pressure is obtained.

The pressure variation with a 0.001 in. (0.025 mm) difference in adjusting washer thickness is approximately 85 psi (6 kg/cm<sup>2</sup>; 59 kPa).

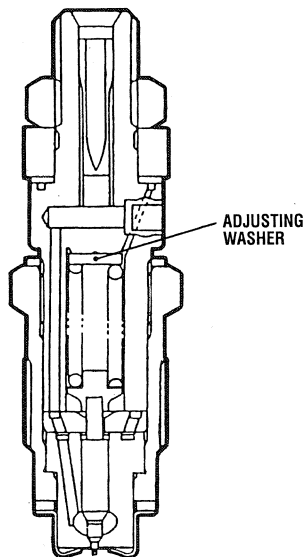

### Nozzle Spraying Condition

1. Install the injection nozzle to a nozzle tester and check the nozzle spraying condition.
2. If the spraying condition is defective, replace the nozzle piece.

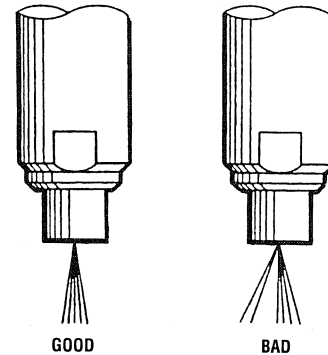

### Valve Seat Tightness

1. Install the injection nozzle to a nozzle tester.
2. Raise the fuel pressure, and keep it at 1849 psi (12.75 MPa; 130 kg/cm<sup>2</sup>) for 10 seconds.
3. If any fuel leak is found, replace the nozzle piece.

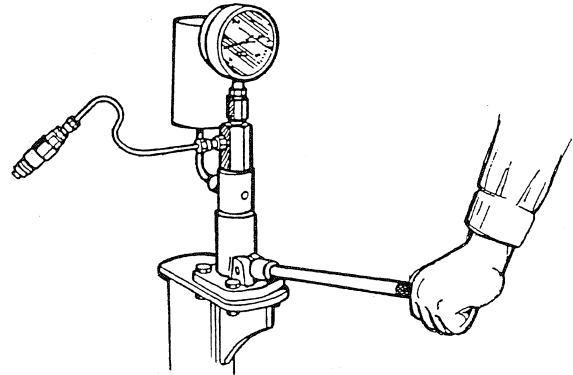

### Fuel Injectors Service

In case of severe vibrations and detonation noise, have the injectors checked and overhauled by an authorized fuel injection service center. Poor fuel quality, contaminants and loss of positive fuel pressure to the injection pump can result in injector faults. Since fuel injectors must be serviced in a clean room environment, it is best to carry at least one extra injector as a spare should a problem occur.

Before removing the old injector, clean the area around the base of the injector to help prevent any rust or debris from falling down into the injector hole. If the injector will not lift out easily and is held in by carbon build-up or the like, work the injector side-to-side with the aid of the socket wrench to free it, and then lift it out.

The injector seats in the cylinder head on a copper sealing washer. Remove this washer with the injector, and replace it with a new washer when the new injector is installed.

**Injector to cylinder head tightening torque:**  
36.2 – 50.6 ft-lb (5.0 – 7.0 m-kg) (49.0 – 68.6 Nm)

# ADMIRAL CONTROL PANEL

UNIVERSAL offers two optional panels. Refer to the instruction page that applies to the panel you purchased.

## ADMIRAL PANEL

This manually-operated control panel is equipped with a Key Switch and RPM gauge with an ELAPSED TIME meter which measures the engine's running time in hours and in 1/10 hours. The panel also includes a WATER TEMPERATURE gauge which indicates water temperature in degrees Fahrenheit, an OIL PRESSURE gauge which measures the engine's oil pressure in pounds per square inch, and a DC control circuit VOLTAGE gauge which measures the system's voltage. All gauges are illuminated when the key switch is turned **on** and remain illuminated while the engine is in operation. The panel also contains two rubber-booted pushbuttons, one for PREHEAT and one for START.

When the engine is shut down with the Key Switch turned **off**, the water temperature gauge will continue to register the last temperature reading indicated by the gauge before electrical power was turned **off**. The oil pressure gauge will fall to zero when the Key Switch is turned **off**. The temperature gauge will once again register the engine's true temperature when electrical power is restored to the gauge.

A separate alarm buzzer with harness is supplied with every Admiral Panel. The installer is responsible for electrically connecting the buzzer to the four-pin connection on the engine's electrical harness. The installer is also responsible for installing the buzzer in a location where it will be dry and where it will be audible to the operator should it sound while the engine is running. The buzzer will sound when the ignition key is turned **on** and should silence when the engine has started and the engine's oil pressure rises above 15 psi.

**Note:** Refer to the *WIRING DIAGRAM* in this manual for the installation of two engine senders.

**WATER TEMPERATURE GAUGE:** THIS GAUGE IS GRADUATED IN DEGREES FAHRENHEIT AND IS ILLUMINATED WHILE THE KEY SWITCH IS TURNED **ON**. THE ENGINE'S NORMAL OPERATING TEMPERATURE IS 170°-190° F (77°-88°C).

**OIL PRESSURE GAUGE:** THIS GAUGE IS GRADUATED IN POUNDS PER SQUARE INCH (PSI) AND IS ILLUMINATED WHILE THE KEY SWITCH IS TURNED **ON**. THE ENGINE'S NORMAL OPERATING OIL PRESSURE RANGES BETWEEN 30-60 PSI.

**RPM GAUGE:** REGISTERS REVOLUTIONS PER MINUTE OF THE ENGINE AND CAN BE RECALIBRATED FOR ACCURACY FROM THE REAR OF THE PANEL.

**HOURLY METER:** REGISTERS ELAPSED TIME, AND SHOULD BE USED AS A GUIDE FOR THE MAINTENANCE SCHEDULE.

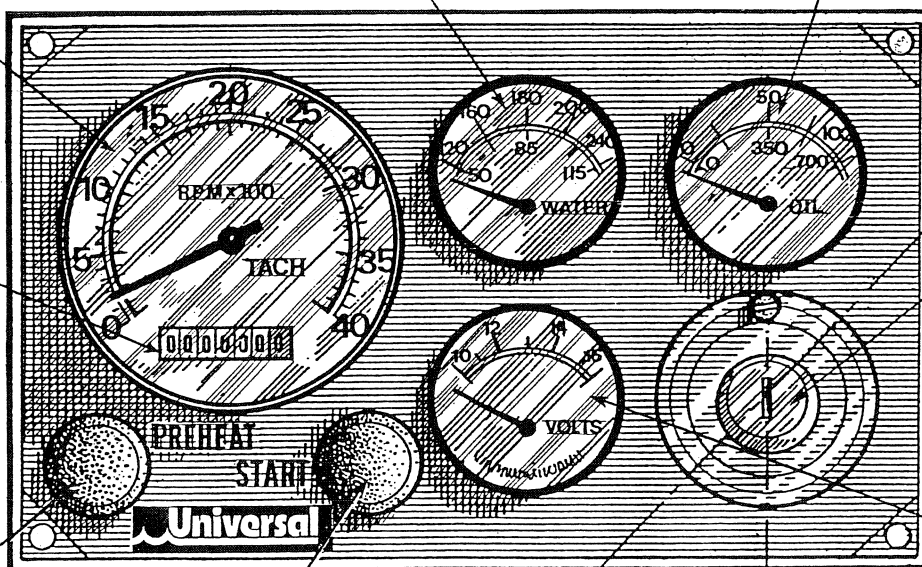

**KEY SWITCH:** PROVIDES POWER ONLY TO THE INSTRUMENT PANEL CLUSTER.

**DC VOLTMETER:** INDICATES THE AMOUNT THE BATTERY IS BEING CHARGED. SHOULD SHOW 13V TO 14V.

**PREHEAT BUTTON:** WHEN PRESSED, ENERGIZES THE ALTERNATOR'S REGULATOR, THE FUEL LIFT PUMP, AND THE ENGINE'S GLOW PLUGS, AND BYPASSES THE ENGINE'S OIL PRESSURE ALARM SWITCH. IN ADDITION, THIS BUTTON ENERGIZES THE **START** BUTTON.

**START BUTTON:** WHEN PRESSED, ENERGIZES THE STARTER'S SOLENOID WHICH CRANKS THE ENGINE. THIS BUTTON WILL NOT OPERATE ELECTRICALLY UNLESS THE **PREHEAT** BUTTON IS PRESSED AND HELD AT THE SAME TIME.

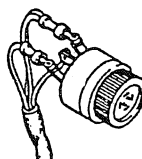

### AUTOMATIC ALARM SYSTEM

**HIGH WATER TEMPERATURE ALARM:** AN ALARM BUZZER HAS BEEN SUPPLIED WITH THE INSTRUMENT PANEL. IF THE ENGINE'S FRESH WATER COOLANT REACHES 210° F (98°C), THIS SWITCH WILL CLOSE SOUNDING THE ALARM WHICH WILL EMIT A *CONTINUOUS* SIGNAL.

**LOW OIL PRESSURE ALARM:** A LOW OIL PRESSURE ALARM SWITCH IS LOCATED OFF THE ENGINE'S OIL GALLERY. THIS SWITCH MONITORS THE ENGINE'S OIL PRESSURE. SHOULD THE ENGINE'S OIL PRESSURE FALL TO 5 - 10 PSI, THE SWITCH WILL OPEN SOUNDING THE ALARM. IN THIS EVENT, THE ALARM WILL EMIT A *PULSATING* SIGNAL.

# CAPTAIN CONTROL PANEL

## CAPTAIN PANEL

This manually-operated control panel is equipped with a Key Switch, an RPM gauge, PREHEAT and START buttons, an INSTRUMENT TEST button and three indicator lamps, one for ALTERNATOR DISCHARGE, one for low OIL PRESSURE,

and one for high ENGINE COOLANT TEMPERATURE. It also includes an alarm buzzer for low OIL PRESSURE or high WATER TEMPERATURE. The RPM gauge is illuminated when the Key Switch is turned **on** and remains illuminated while the engine is in operation.

**RPM GAUGE:**  
REGISTERS REVOLUTIONS PER MINUTE OF THE ENGINE AND CAN BE RECALIBRATED FOR ACCURACY FROM THE REAR OF THE PANEL.

**ALARM:** THE ALARM WILL SOUND IF THE ENGINE'S OIL PRESSURE FALLS BELOW 5 - 10 PSI. IN THIS EVENT, THE ALARM WILL EMIT A *PULSATING* SIGNAL. THE ALARM WILL ALSO SOUND IF THE WATER TEMPERATURE IN THE FRESHWATER COOLING CIRCUIT RISES TO 210°F. IN THIS EVENT, THE ALARM WILL EMIT A SIGNAL.

**NOTE:** THE ALARM WILL SOUND WHEN THE KEY SWITCH IS TURNED ON. THIS SOUNDING IS NORMAL. ONCE THE ENGINE STARTS AND THE ENGINE'S OIL PRESSURE REACHES 15 PSI, THE ALARM WILL SILENCE.

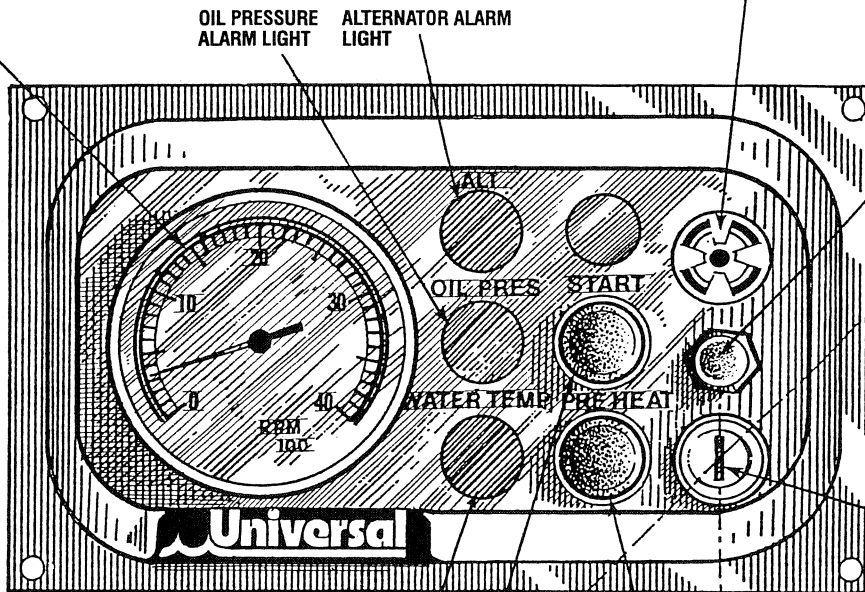

**TEST BUTTON:** WHEN PRESSED, TESTS THE ALTERNATOR, THE OIL PRESSURE, AND THE WATER TEMPERATURE CONTROL CIRCUITS. WHEN PRESSED, THE ALTERNATOR, THE OIL PRESSURE, AND THE WATER TEMPERATURE INDICATOR LIGHTS ILLUMINATE IN ADDITION TO SOUNDING THE ALARM BUZZER.

**KEY SWITCH:** PROVIDES POWER TO THE INSTRUMENT PANEL CLUSTER AND THE DC ALTERNATOR REGULATOR TERMINAL.

**WATER TEMPERATURE ALARM LIGHT**

**START BUTTON:** WHEN PRESSED, ENERGIZES THE STARTER'S SOLENOID WHICH CRANKS THE ENGINE. THIS BUTTON WILL NOT OPERATE ELECTRICALLY UNLESS THE PREHEAT BUTTON IS PRESSED AND HELD AT THE SAME TIME.

**PREHEAT BUTTON:** WHEN PRESSED, ENERGIZES THE FUEL LIFT PUMP AND THE ENGINE'S GLOW PLUGS, AND BYPASSES THE ENGINE'S OIL PRESSURE ALARM SWITCH. IN ADDITION, THIS BUTTON ENERGIZES THE START BUTTON.

# CONTROL PANEL TROUBLESHOOTING

## TACHOMETER/HOURMETER

The tachometer/hourmeter used in propulsion engine instrument panels contains two separate electrical circuits with a common ground. One circuit operates the hourmeter and the other the tachometer. The hourmeter circuit operates on 12 volts alternator charging voltage supplied to the (+) terminal on the back of the instrument.

The tachometer circuit operates on AC voltage 6 – 8 volts, fed from one of the diodes in the alternator and supplied to the tachometer input terminal while the engine is running, and the alternator producing battery charging voltage 13.0 – 14.8 volts DC.

The following are procedures to follow when troubleshooting a fault in either of the two circuits in a tachometer/hourmeter.

### Hourmeter Inoperative

Check for the proper DC voltage between (+) and (-) terminals.

1. Voltage present - meter is defective - repair or replace.
2. Voltage not present - trace (+) and (-) electrical connections for fault. (Jump 12 volts DC to meter (+) terminal to verify the operation.)

### Tachometer Inoperative

Check for the proper AC voltage between tachometer input terminal and (-) terminal with the engine running.

1. Voltage present - attempt adjusting meter through calibration access hole. No results, repair or replace meter.
2. AC voltage not present - check for proper alternator DC output voltage.
3. Check for AC voltage at tach terminal on alternator to ground.
4. Check electrical connections from tachometer input terminal to alternator connection.

### Tachometer Sticking

1. Check for proper AC voltage between "tach inp." terminal and (-) terminal.
2. Check for good ground connection between meter (-) terminal and alternator.
3. Check that alternator is well grounded to engine block at alternator pivot bolt.

### Tachometer Inaccurate

- a. With a hand-held tach on the front of the crankshaft pulley retaining nut or with a strobe-type tach, read the front crankshaft pulley rpm at idle.
- b. Adjust the tachometer with a small Phillips type screwdriver through the calibration access hole in the rear of the tachometer. Zero the tach and bring it to the rpm indicated by the strobe or hand tach. (Verify the rpm at idle and at high speed). (Adjust the tach as needed.)

**NOTE:** Current model tachometers use a coarse adjustment dial to set the tachometer to the crankshaft pulley rpms. The calibrating screw is then used for fine tuning.

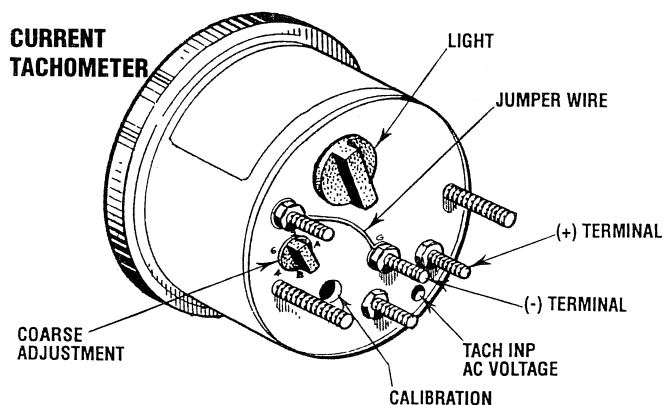

## IDLE SPEED ADJUSTMENT & TACHOMETER CHECK (New Installation)

### Checking the idle speed

**NOTE:** In a new installation having new instrument panels, the tachometer may not always be correctly calibrated to the engine's rpm. This calibration should be checked in all new installations.

1. Warm up the engine to normal operating temperature. Remove any specks on the crankshaft pulley with a clean cloth and place a piece of suitable reflecting tape on the pulley to facilitate use of a photoelectric type tachometer.
2. Start and idle the engine.
3. Aim the light of the tachometer onto the reflecting tape to confirm the engine speed. Check the instrument panel tachometer reading. Adjust the tachometer in the panel by using the instrument coarse adjustment to calibrate the instrument reading to the closest R.P.M. that the photo tach is showing. Then use the fine calibration adjustment to bring the instrument to the exact reading as the photo tach. The fine calibration adjustment is made using a 5/64 Allen head wrench.
4. Adjust the idle speed if the engine speed is not within the specified value.

### Normal idle speed:

M-25XPB:	1,000 – 1,200 rpm
M-35B:	800 – 1,000 rpm
M-40B:	800 – 1,000 rpm

# CONTROL PANEL TROUBLESHOOTING

## MANUAL STARTER DISCONNECT (TOGGLE SWITCHES)

**NOTE:** *The engine control system is protected by a 20 amp manual reset circuit breaker located on the engine as close as possible to the power source.*

Problem	Probable Cause	Verification/Remedy
<b>PREHEAT</b> depressed, no panel indications fuel solenoid, electric fuel pump and preheat solenoid not energized.	<ol style="list-style-type: none"> <li>1. Oil Pressure switch.</li> <li>2. 20 amp circuit breaker tripped.</li> </ol>	<ol style="list-style-type: none"> <li>1. Check switches and/or battery connections.</li> <li>2. Reset breaker. If opens again, check preheat solenoid circuit and run circuit for shorts to ground.</li> </ol>
<b>START SWITCH DEPRESSED</b> , no starter engagement.	<ol style="list-style-type: none"> <li>1. Connection to solenoid faulty.</li> <li>2. Faulty switch</li> <li>3. Faulty solenoid.</li> <li>4. Loose battery connections.</li> <li>5. Low battery.</li> </ol>	<ol style="list-style-type: none"> <li>1. Check connection.</li> <li>2. Check switch with ohmmeter.</li> <li>3. Check that 12 volts are present at the solenoid connection.</li> <li>4. Check battery connections.</li> <li>5. Check battery charge state.</li> </ol>
<b>NO IGNITION</b> , cranks, does not start.	<ol style="list-style-type: none"> <li>1. Faulty fueling system.</li> <li>2. Check for air in the fuel system.</li> <li>3. Faulty fuel lift pump.</li> </ol>	<ol style="list-style-type: none"> <li>1. Check for fuel.</li> <li>2. Allow system to bleed.</li> <li>3. Replace fuel lift pump.</li> </ol>
<b>NOT CHARGING BATTERY</b>	<ol style="list-style-type: none"> <li>1. Faulty alternator drive.</li> </ol>	<ol style="list-style-type: none"> <li>1. Check the drive belt and its tension. Be sure the alternator turns freely. Check for loose connections. Check the output with a voltmeter. Ensure 12V are present at the regulator terminal.</li> </ol>
<b>BATTERY RUNS DOWN</b>	<ol style="list-style-type: none"> <li>1. Oil pressure switch.</li> <li>2. High resistance leak to ground.</li> <li>3. Low resistance leak to ground.</li> <li>4. Faulty alternator.</li> </ol>	<ol style="list-style-type: none"> <li>1. Observe if the gauges and panel lights are activated when the engine is not running. Test the oil pressure switch.</li> <li>2. Check the wiring. Insert sensitive (0-.25 amp) meter in battery lines (Do NOT start engine). Remove connections and replace after short is located.</li> <li>3. Check all wires for temperature rise to locate the fault.</li> <li>4. After a good battery charging, disconnect alternator at output. If leakage stops. Remove alternator and bench test. Repair or replace.</li> </ol>

### TROUBLESHOOTING WATER TEMPERATURE AND OIL PRESSURE GAUGES

If the gauge reading is other than what is normally indicated by the gauge when the instrument panel is energized, the first step is to check for 12 volts DC between the ignition (B+) and the Negative (B-) terminals of the gauge.

Assuming that there is 12 volts as required, leave the instrument panel energized (key switch on) and perform the following steps:

1. Disconnect the sender wire at the gauge and see if the gauge reads zero, which is the normal reading for this situation.
2. Connect the sender terminal at the gauge to ground and see if the gauge reads full scale, which is the normal reading for this situation.

If both of the above gauge tests are positive, the gauge is undoubtedly OK and the problem lies either with the conductor from the sender to the gauge or with the sender.

If either of the above gauge tests are negative, the gauge is probably defective and should be replaced.

Assuming the gauge is OK, check the conductor from the sender to the sender terminal at the gauge for continuity.

Check that the engine block is connected to the ground. Some starters have isolated ground terminals and if the battery is connected to the starter (both plus and minus terminals), the ground side will not necessarily be connected to the block.



# GLOW PLUG SERVICE

## GLOW PLUGS

The glow plugs are wired through the preheat solenoid. When PREHEAT is pressed at the control panel this solenoid should “click” on and the glow plug should begin to get hot.

### Inspection

To inspect the plug, remove the electrical terminal connections, then unscrew or unclamp each plug from the cylinder head. Thoroughly clean each plug’s tip and threads with a soft brush and cleaning solution to remove all the carbon and oil deposits. While cleaning, examine the tip for wear and burn erosion; if it has eroded too much, replace the plug.

### Testing

An accurate way to test glow plugs is with an ohmmeter. This method can be used with the plug in or out of the engine. You can also use an ammeter to test the power drain (8 – 9 amps per plug).

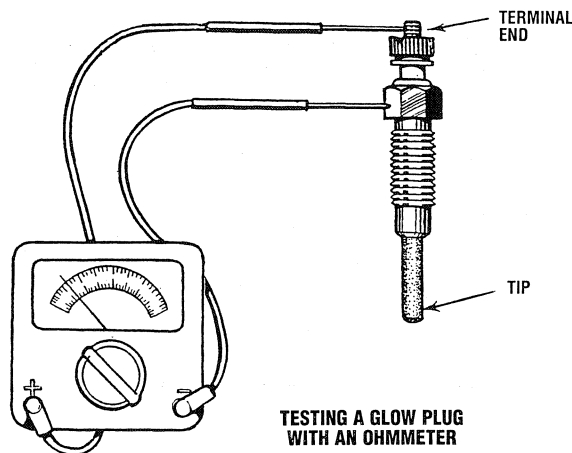

**WARNING:** *These glow plugs will become very hot to the touch. Be careful not to burn your fingers when testing the plugs.*

1. Disconnect the leads from the glow plugs.
2. Measure the resistance with the ohmmeter across the glow plug terminal and the body of the glow plug (see illustration).
3. If 0 ohm is indicated, the screw at the tip of the glow plug and the body of the glow plug are short-circuited.
4. If the standard value is not indicated, the glow plug is faulty; replace the glow plug.

**NOTE:** *Refer to the TORQUE page for the glow plug tightening torque.*

#### GLOW PLUG RESISTANCE

STANDARD VALUE: Approx. 0.9 to 1.2 ohm

Re-install the plugs in the engine and test them again. The plugs should get very hot (at the terminal end) within 7 to 15 seconds. If the plugs don’t heat up quickly, check for a short circuit. When reinstalling the glow plugs, use anti-seize compound on the threads.

**WARNING:** *Do not keep a glow plug on for more than 30 seconds.*

# STARTER SERVICE

## STARTER DESCRIPTION

The magnet-switch type starter is composed of two main sections. The first section converts battery current into mechanical rotation to turn the engine crankshaft. It is composed of the field coil, armature, brush, commutator, pinion, overrunning clutch, etc. The second section allows the pinion and flywheel to engage together and current to flow through the motor section. It is composed of the pull-in coil, holding coil, plunger, drive lever, contact plate, etc.

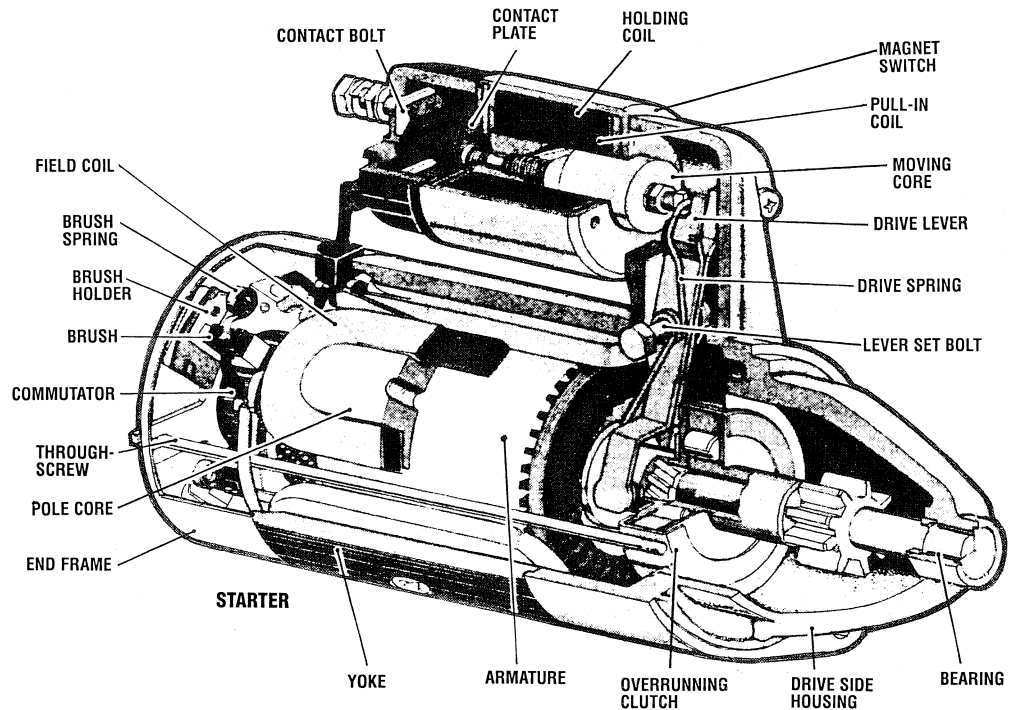

## STARTER TESTING

### Motor Test

**CAUTION:** *Secure the starter in a vise to prevent it from moving while testing the motor.*

1. Disconnect the ground cable clamp from the battery negative terminal post.
2. Disconnect the battery positive cable and the leads from the starter.
3. Remove the starter motor from the engine.
4. Disconnect the connecting lead from the starter terminal C.
5. Connect a jumper lead from the connecting lead to the battery positive terminal post.
6. Connect a jumper lead momentarily between the starter motor housing and the battery negative terminal post.
7. If the motor does not run, check the motor.

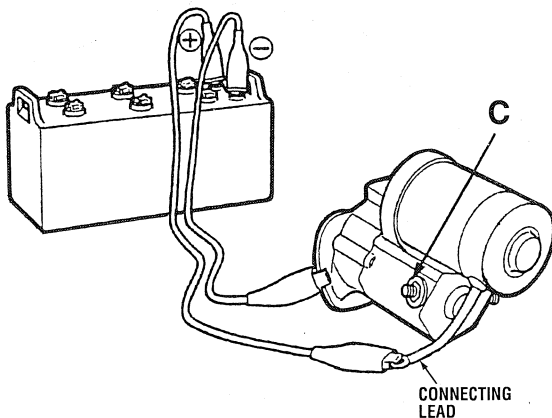

### Magnet Switch Test (Pull-in, Holding Coils)

1. Remove the motor from the starter housing.
2. Prepare a 6 volt battery for the test.
3. Connect jumper leads from the battery negative terminal to the housing and the starter terminal C.
4. If the plunger is attracted and the pinion gear pops out when a jumper lead is connected from the battery positive terminal to the S terminal, the pull-in coil is good; if not, it is defective.
5. Disconnect the jumper lead to the starter terminal C. Then the pinion gear should remain popped out.

**NOTE:** *Testing time must be 3 to 5 seconds.*

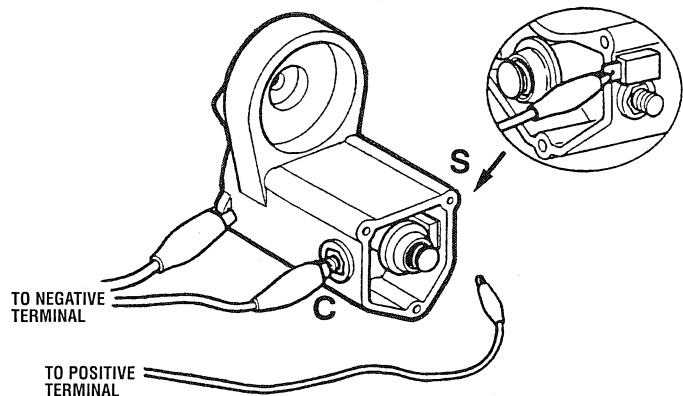

# STARTER SERVICE

## STARTER DISASSEMBLY & REASSEMBLY

### Motor

1. Disconnect the connecting lead from the magnet switch.
2. Remove the through-screws, and then separate the end frame, yoke and armature.
3. Remove the two screws and then take out the brush holder from the end frame.

### When Reassembling:

Apply grease to the spline teeth of the armature.

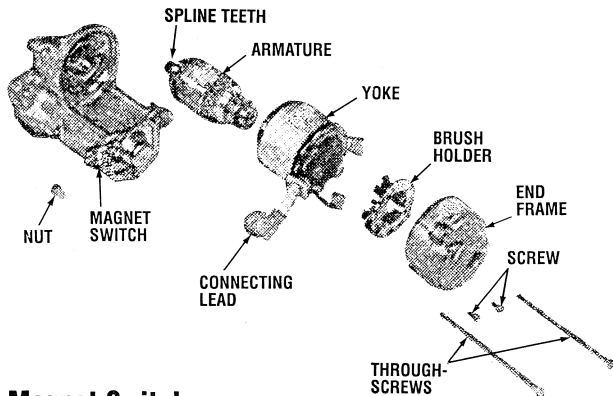

### Magnet Switch

1. Remove the drive end frame mounting screws.
2. Remove the overrunning clutch, ball, spring, gear, rollers and retainer.

### When Reassembling:

Apply grease to the gear teeth of the gear, overrunning clutch and ball.

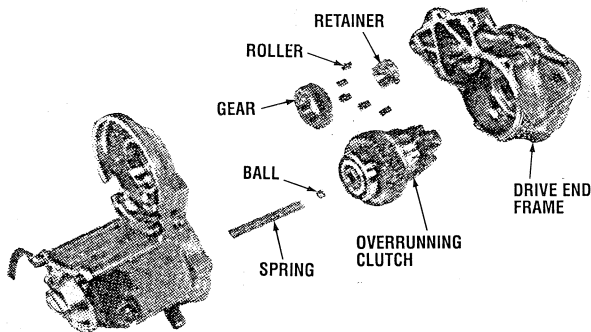

### Plunger

1. Remove the end cover.
2. Remove the plunger.

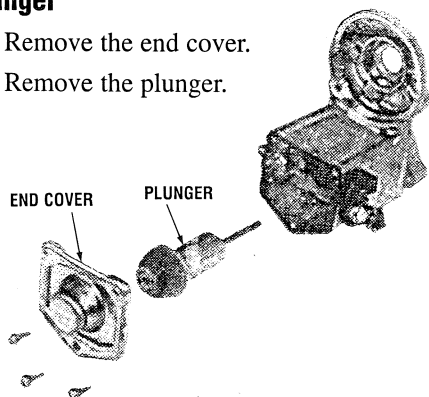

## STARTER SERVICE

### Commutator and Mica

1. Check the contact face of the commutator for wear, and grind the commutator with emery paper if it is slightly worn.

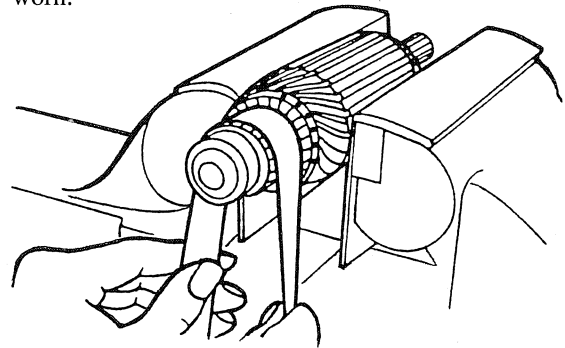

2. Measure the commutator O.D. with an outside micrometer at several points.
3. If the minimum O.D. is less than the limit, replace the armature.
4. If the difference of the O.D.'s exceeds the limit, correct the commutator on a lathe to the standard value.

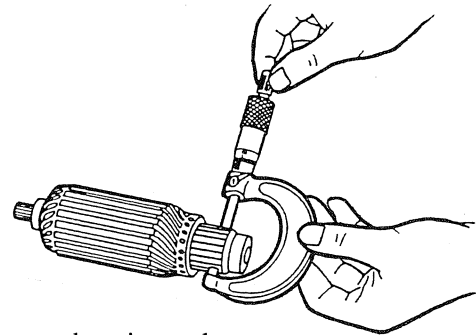

5. Measure the mica undercut.
6. If the undercut is less than the limit, correct it with a saw blade and chamfer the segment edges.

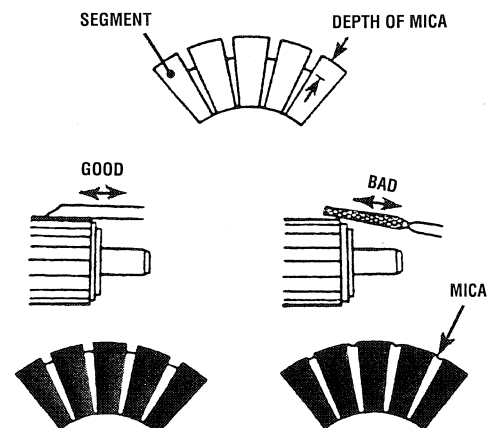

# STARTER SERVICE

## Brush Wear

1. If the contact face of the brush is dirty or dusty, clean it with emery paper.
2. Measure the brush length with vernier calipers.
3. If the length is less than the limit, replace the yoke assembly and brush holder.

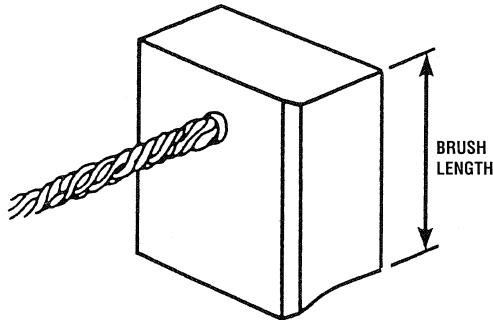

## Brush Holder

1. Check the continuity across the brush holder and the holder support with an ohmmeter.
2. If it conducts, replace the brush holder.

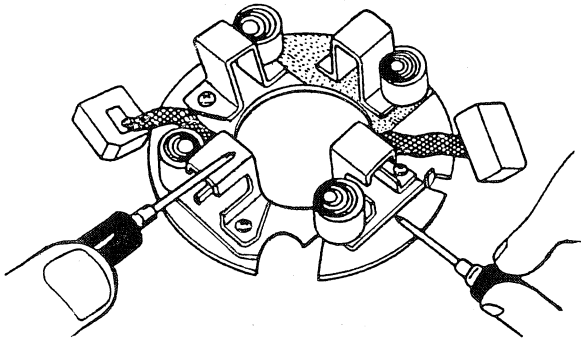

## Armature Coil

1. Check the continuity across the commutator and armature coil core with an ohmmeter.
2. If it conducts, replace the armature.

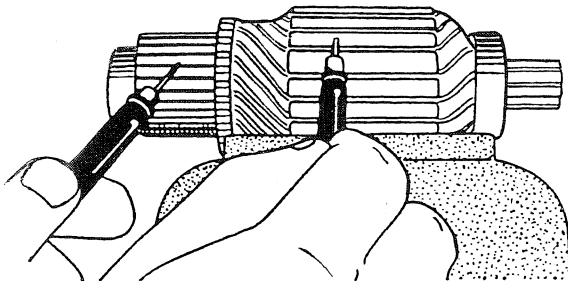

3. Check the continuity across the segments of the commutator with an ohmmeter.
4. If it does not conduct, replace the armature.

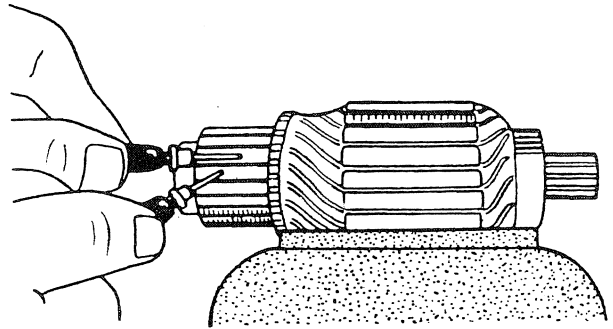

## Field Coil

1. Check the continuity across the lead and brush with an ohmmeter.
2. If it does not conduct, replace the yoke assembly.

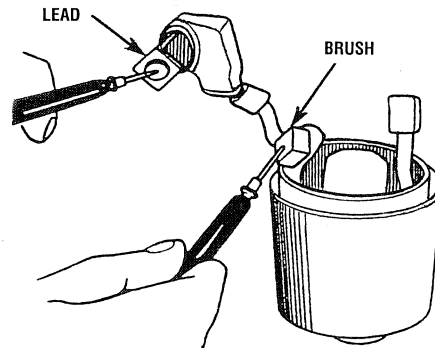

3. Check the continuity across the brush and yoke with an ohmmeter.
4. If it conducts, replace the yoke assembly.

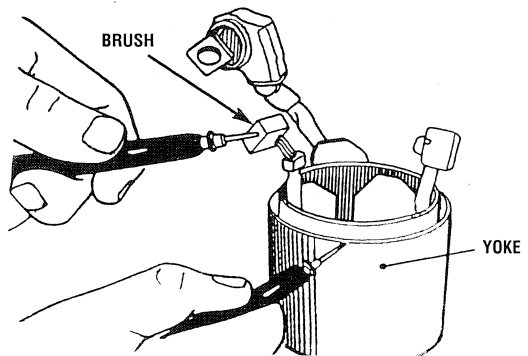

# STARTER SERVICE

## Armature Bearing

1. Check the bearing for smooth rotation.
2. If it does not rotate smoothly, replace it.

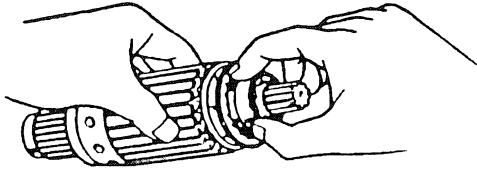

## Overrunning Clutch

1. Inspect the pinion for wear or damage.
2. If there is any defect, replace the overrunning clutch assembly.
3. Check that the pinion turns freely and smoothly in the overrunning direction and does not slip in the cranking direction.
4. If the pinion slips or does not turn in both directions, replace the overrunning clutch assembly.

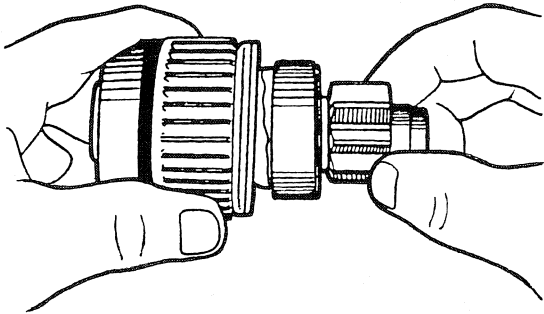

## Magnet Switch

1. Check the continuity across terminal C and terminal B with an ohmmeter while pushing the plunger.
2. If it does not conduct, check the contacts.

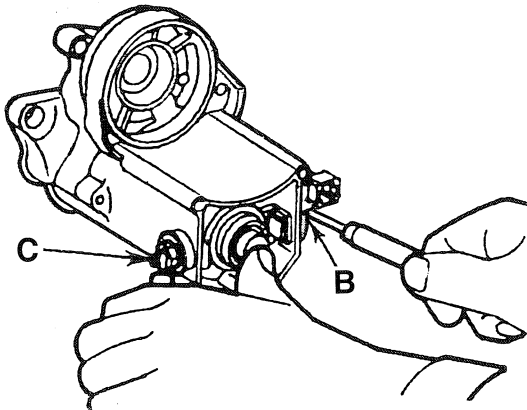

# MANDO ALTERNATOR SERVICE

## PRECAUTIONS FOR TESTING ALTERNATOR

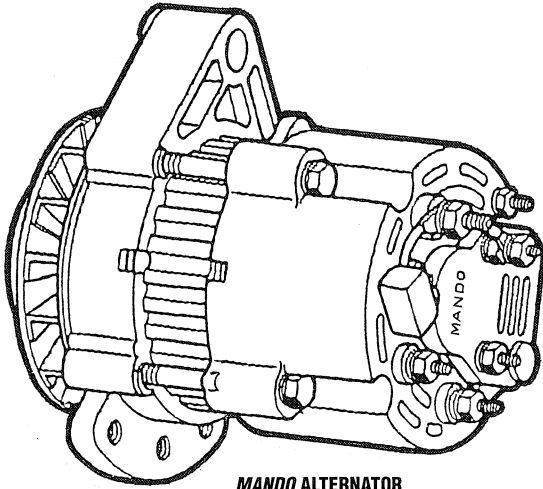

MANDO ALTERNATOR

**WARNING:** Be sure that the engine compartment is well ventilated and that there is no gasoline vapor present. This is to prevent the possibility of an explosion and/or fire should a spark occur.

**WARNING:** Keep fingers and clothing away from the alternator belt and pulley; severe bodily harm can occur.

### CAUTION:

1. Do not attempt to polarize the alternator.
2. Do not short across or ground any of the terminals on the alternator, except as specifically instructed in the troubleshooting tests.
3. Never disconnect the alternator-output lead or battery cables when the alternator is being driven by the engine.
4. Never disconnect the regulator lead from the alternator-regulator terminal when the alternator is being driven by the engine.
5. Always remove the negative (-) battery cable from the battery before working on the alternator system.
6. When installing the battery, be sure to connect the negative (-) (grounded) battery cable to the negative (-) battery terminal and the positive (+) battery cable to the positive (+) battery terminal.
7. If a charger or booster battery is to be used, be sure to connect it in parallel with the existing battery (positive to positive; negative to negative).

## TORQUE SPECIFICATIONS

TORQUE SPECIFICATIONS		
Fastener Location	lb-ft Nm	lb-in. Nm
Alternator front housing screws	—	25 – 35 lb-in. (2.8 – 4.0 Nm)
Alternator end frame screws	—	35 – 65 lb-in. (4.0 – 7.3 Nm)
Alternator pulley nut	35 – 50 lb-ft (47 – 68 Nm)	—
Regulator mounting screws	—	25 – 45 lb-in. (2.8 – 5.1 Nm)

## PREPARING TO CHECK ALTERNATOR

Before starting the alternator tests, check these items:

1. If the problem is an undercharged battery, check to ensure that the undercharged condition has not been caused by an excessive accessory current draw or by accessories which have accidentally been left on. Also, check that the undercharged condition has not been caused by running the engine at too low a speed for extended periods of time.
2. Check the physical condition and the state of charge of the battery. The battery *must be* fully charged to obtain valid results in the following tests. If not, charge the battery before testing the system.
3. Inspect the entire alternator system wiring for defects. Check all connections for tightness and cleanliness, particularly the battery cable clamps and battery terminals.

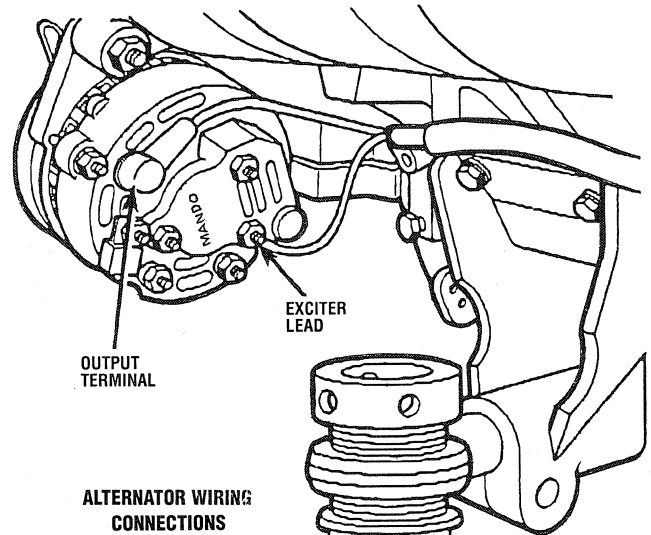

4. Check the alternator drive belt for excessive wear, cracks, fraying and glazed surfaces, and replace it if necessary. Also check the drive belt tension and adjust it if necessary (see *DRIVE BELT ADJUSTMENT* under *ENGINE ADJUSTMENTS*).

# MANDO ALTERNATOR SERVICE

## TEST OUTPUT CIRCUIT

1. Connect the positive voltmeter lead to the alternator output terminal and the negative lead to the ground terminal on the alternator (see illustration).
2. Wiggle the engine wiring harness while observing the voltmeter. The meter should indicate the approximate battery voltage, and should not vary. If no reading is obtained, or if the reading varies, check the alternator-output circuit for loose or dirty connections or damaged wiring.

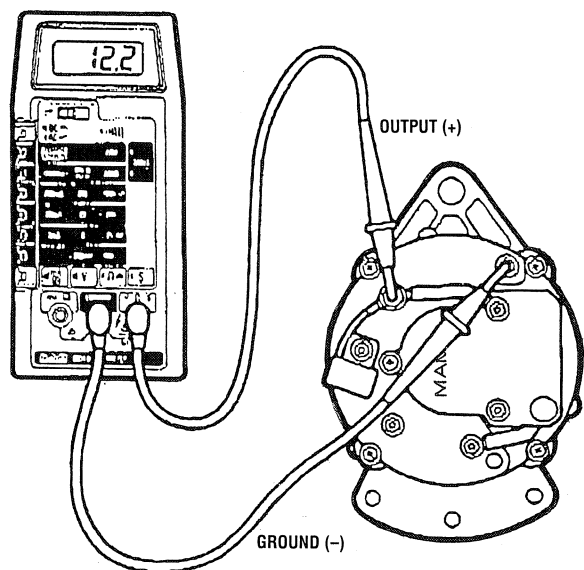

TESTING ALTERNATOR OUTPUT CIRCUIT

## TEST EXCITATION CIRCUIT

1. Connect the positive (+) voltmeter lead to the excitation terminal on the alternator and the negative (-) lead to the ground terminal on the alternator.

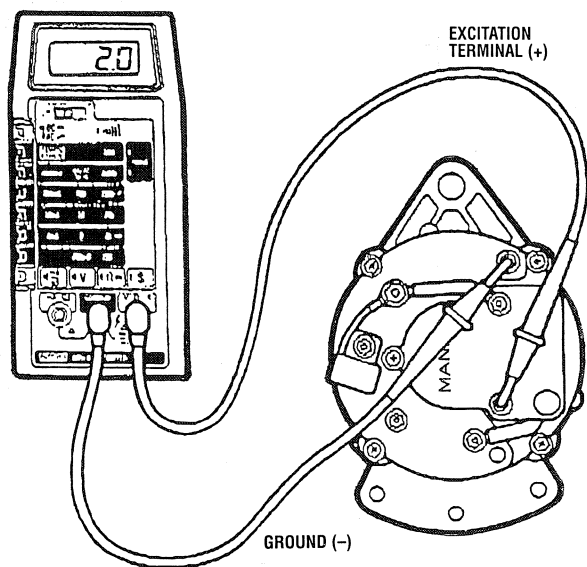

TESTING EXCITER CIRCUIT

2. Turn the ignition switch to the on position and note the voltmeter reading. The reading should be 1.3 to 2.5 volts (see illustration).
3. **If the reading is between .75 and 1.1 volts**, the rotor field circuit probably is shorted or grounded. Disassemble the alternator and test the rotor as described under *CLEAN AND TEST ALTERNATOR COMPONENTS* in this section.
4. **If the reading is between 6.0 and 7.0 volts**, the rotor field circuit probably is open. Remove the regulator and inspect it for worn brushes or dirty slip rings. Replace the brushes if they are less than 1/4 in. (6 mm) long. If the brushes and slip rings are in good condition, disassemble the alternator and test the rotor, as outlined under *CLEAN AND TEST ALTERNATOR COMPONENTS* in this section.
5. **If no reading is obtained**, an open exists in the alternator-excitation lead or in the excitation circuit of the regulator. Disconnect the lead from the regulator. Connect the positive voltmeter lead to this lead, and the negative voltmeter lead to ground. If the voltmeter now indicates an approximate battery voltage, the voltage regulator is defective and must be replaced. If no voltage is indicated, check the excitation circuit for loose or dirty connections or damaged wiring (see illustration).

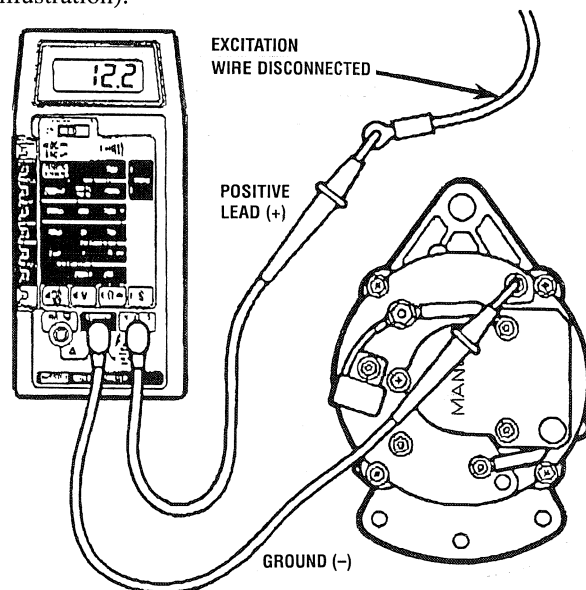

TESTING EXCITER LEAD

# MANDO ALTERNATOR SERVICE

## TEST ALTERNATOR CURRENT OUTPUT

Perform this test to check if the alternator is capable of producing the rated current output, using a 0 – 55 amp DC ammeter.

1. Disconnect the negative (-) battery cable from the battery.
2. Disconnect the output lead from the alternator-output terminal and connect the ammeter in series between the lead and the output terminal. Connect the positive side of the ammeter toward the output terminal.
3. Reconnect the negative battery cable.
4. Diesel: Operate the engine stop lever. Perform this so the engine can be cranked with the starter motor and not start. Turn on all accessories and crank the engine over with the starter motor for 15 – 20 seconds.
5. Turn off the accessories. Return the stop lever to the run position. Start the engine and adjust the engine speed to 1500 – 2000 rpm. Quickly observe the ammeter. The reading should be at least 30 amps (see illustration).

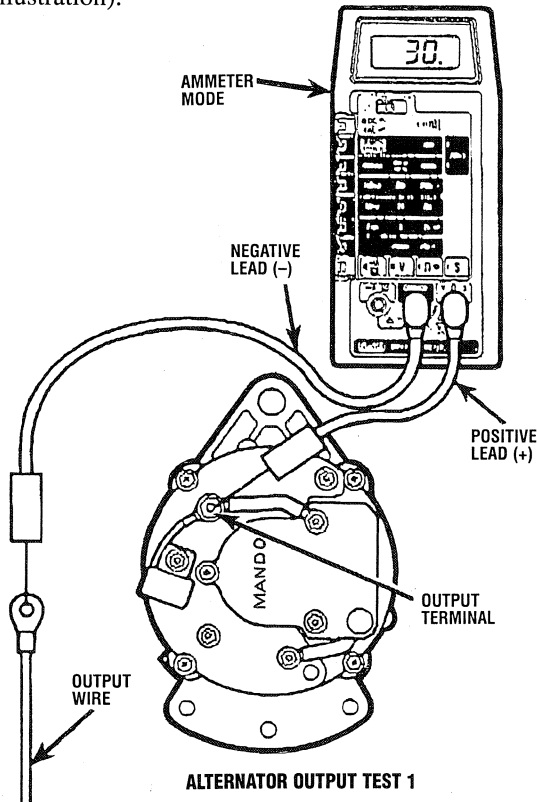

7. If the reading is now within the specifications, the diode trio is faulty. Disassemble the alternator and replace the diode trio, as explained in this section.
8. If the reading is still low with the jumper lead connected, perform the Voltage Regulator Test to determine if the fault is in the regulator or the alternator.

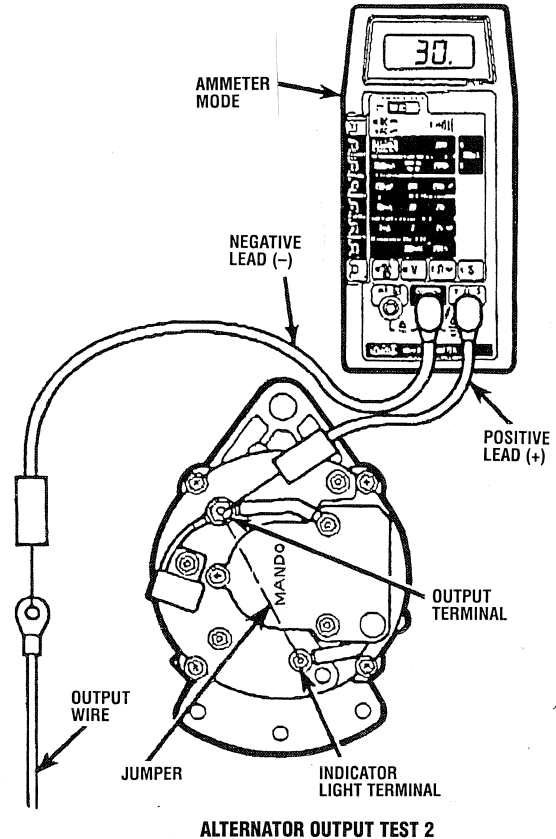

## TEST VOLTAGE REGULATOR

Perform this test to determine if the voltage regulator is operating correctly, using a 0 – 20 volt DC voltmeter.

**NOTE:** The battery *must* be fully charged, 1.265 or above specific gravity, to obtain a proper voltage reading in this test. If necessary, charge the battery with a battery charger or allow the engine to run a sufficient length of time to fully charge the battery before taking a reading.

6. If the reading is low, stop the engine and connect a jumper lead between the alternator-output terminal and the indicator light terminal. Repeat Steps 4 and 5 (see illustration).

1. Connect the positive (+) voltmeter lead to the positive battery terminal and the negative (-) voltmeter lead to the negative terminal (see illustration).



# MANDO ALTERNATOR SERVICE

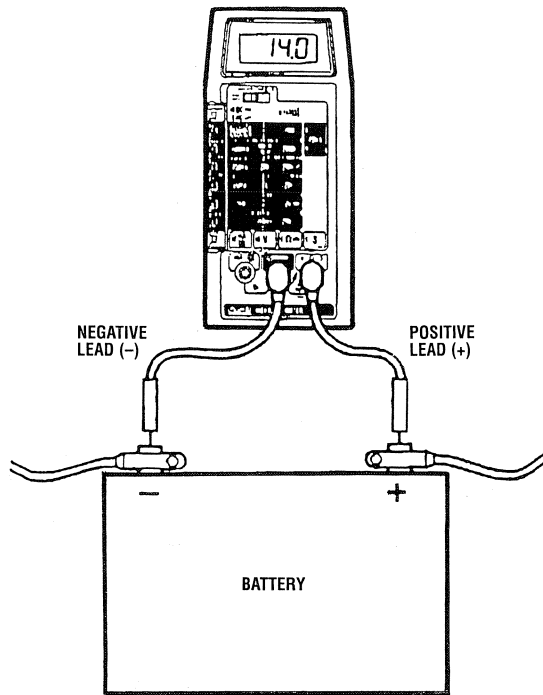

SYSTEM VOLTAGE CHECK

2. Start the engine and run it at fast idle until the engine reaches its normal operating temperature. Adjust the engine speed to 1500 – 2000 rpm and observe the voltmeter for the highest reading. The reading should be between 13.7 and 14.7 volts.
3. If the reading is high, check for a loose or dirty regulator ground lead connection. If the connection is good, the voltage regulator is faulty and must be replaced. Be sure to disconnect the battery cables before attempting to remove the regulator.
4. If the reading is low:
  - a. Stop the engine.
  - b. Remove the Phillips cover screw from the regulator cover (see illustration).

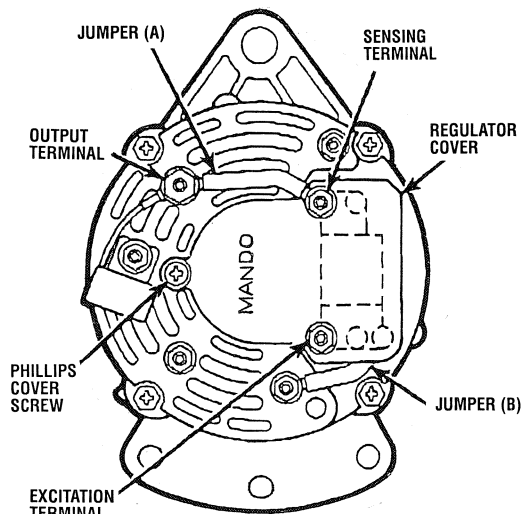

REGULATOR COVER REMOVAL

- c. Remove the nut from the output terminal and the nut from the sensing terminal, and remove Jumper (A).
- d. Remove another nut from the sensing terminal, and the nut from the excitation terminal.
- e. Remove the regulator cover.
- f. Temporarily install Jumper (A) and all associated nuts. Leave Jumper (B) installed.
- g. Remove the plastic plug from the side of the regulator.
- h. Connect a jumper between the top brush lead from the brush and ground (see illustration).

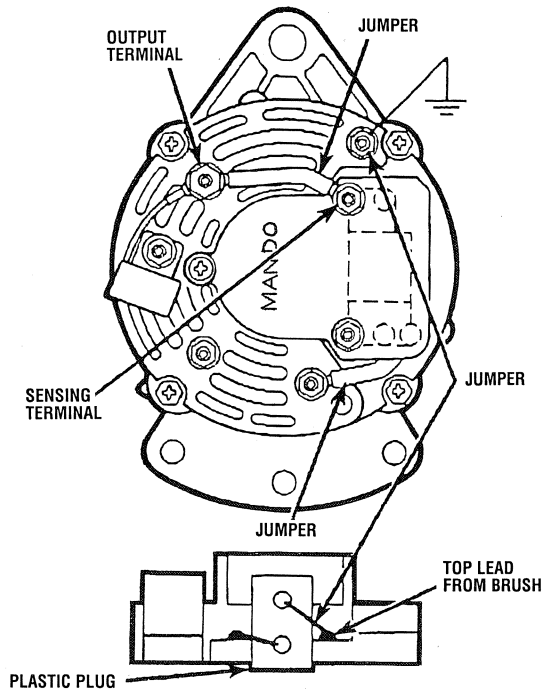

END VIEW OF REGULATOR WITH COVER REMOVED

- i. Repeat steps 1 and 2.

**NOTE:** Do not let the voltage exceed 16 volts.

- j. If a voltmeter reading of 14.5 volts or above is now obtained, the voltage regulator is faulty and must be replaced. If the voltmeter reading is below 14.5 volts, inspect the brushes and slip rings for wear, dirt or damage. If the brushes and slip rings are good, the alternator is faulty internally. Disassemble the alternator and test the components, as outlined in this section.

## REMOVE ALTERNATOR

1. Disconnect the negative (-) battery ground cable.
2. Disconnect the wiring leads.
3. Loosen the screws. Holding the alternator, rotate it toward the engine and lift the belt off the pulley.
4. Remove the screws and washers and remove the alternator.

# MANDO ALTERNATOR SERVICE

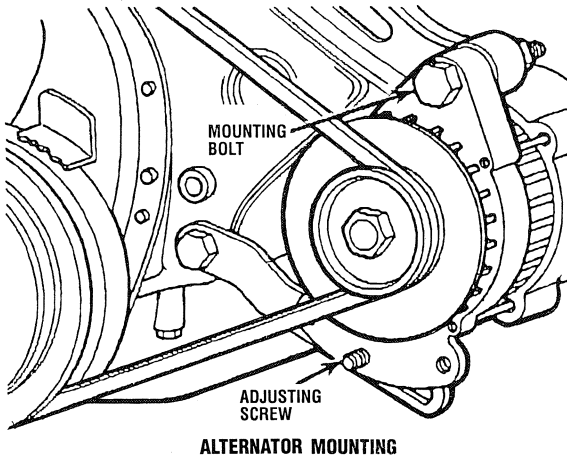

## DISASSEMBLE ALTERNATOR

1. Remove the terminal nuts to remove the jumper (see illustration).
2. Remove the remaining terminal nuts.
3. Remove the capacitor.
4. Remove the Phillips screw from the regulator cover.
5. Remove the brush/regulator-assembly cover.
6. Remove the nut from the terminal.
7. Remove the jumper.
8. Remove the terminal insulators.
9. Remove the two Phillips screws and remove the brush/regulator assembly.

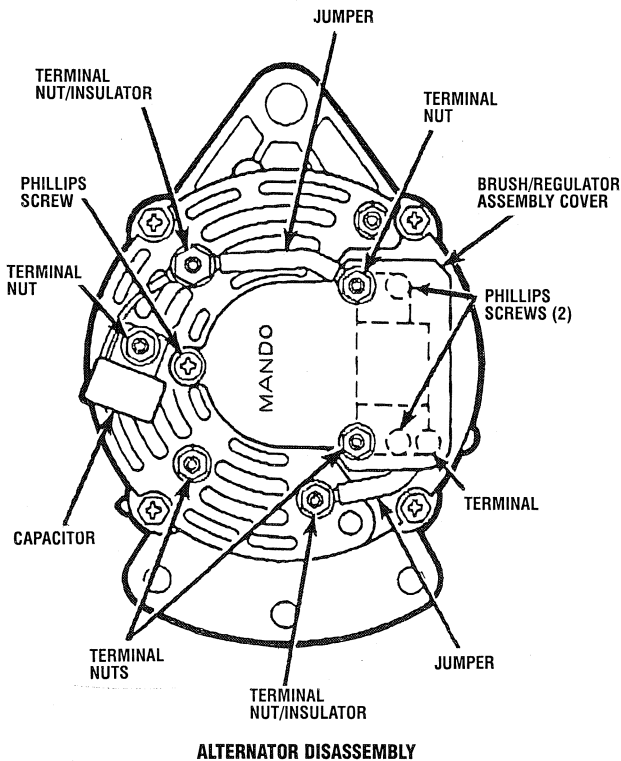

10. Place an oversized V-belt around the pulley and fasten the pulley in a vise.
11. Use a 7/8 in. box wrench to loosen and remove the pulley nut.

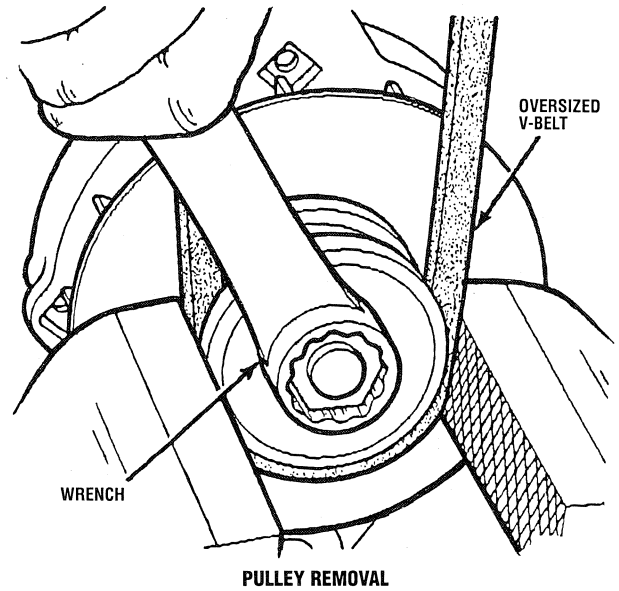

12. Remove the pulley nut, lockwasher, pulley, fan, and spacer (see illustration).

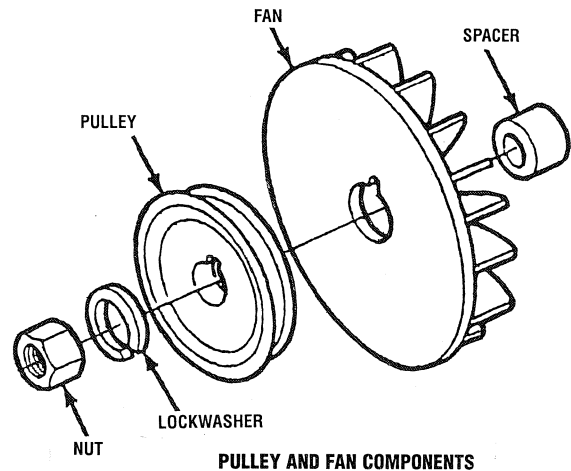

**CAUTION:** DO NOT insert screwdriver blades more than 1/16 in. (1.6 mm). Damage to the stator winding could result from deeper penetration.

**NOTE:** Score the stator, and the front and rear housings so the unit may be reassembled correctly.

13. Remove the four through-bolts and carefully pry the front housing away from the rear housing using two screwdrivers (see illustration).

# MANDO ALTERNATOR SERVICE

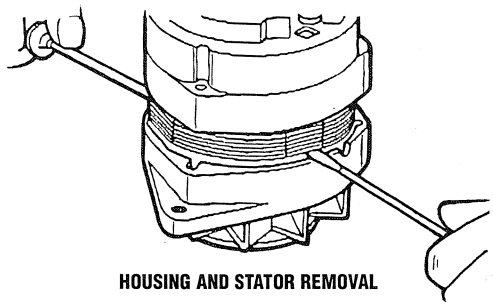

HOUSING AND STATOR REMOVAL

14. Carefully push the rotor assembly out of the front housing and rear housing (see illustration).

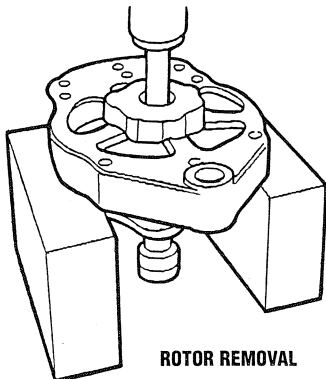

ROTOR REMOVAL

**NOTE:** If the bearing is removed from the housing, a new bearing must be installed.

15. After removing the three bearing locking screws, carefully press the front bearing out of the housing. Press against the inner race of the bearing (see illustration).

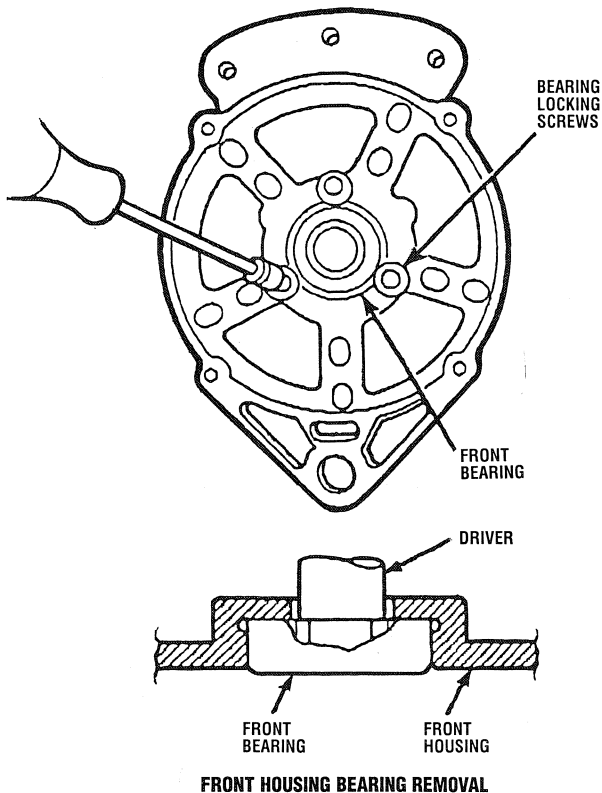

FRONT HOUSING BEARING REMOVAL

16. Remove the rectifier assembly by removing the Phillips screw and lifting out the assembly.

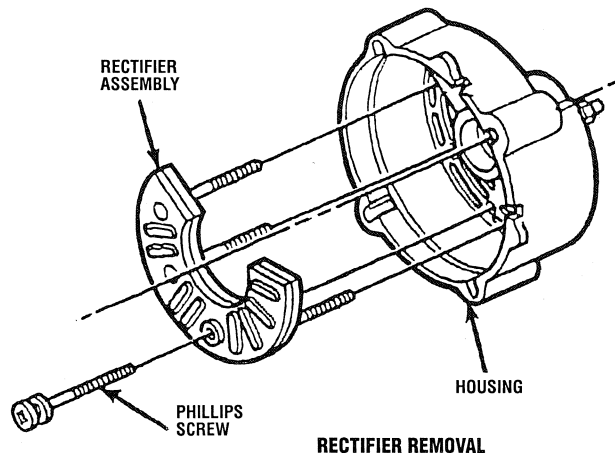

RECTIFIER REMOVAL

## CLEAN AND TEST ALTERNATOR COMPONENTS

1. Inspect and test the brush/regulator assembly. The brush set may be reused if the brushes are 1/4 in. (6 mm) or longer. The brushes must not be oil soaked, cracked or grooved.

Test for continuity between 1 and 2, and 3 and 4 using a test lamp or an ohmmeter. These checks will indicate a good brush/regulator assembly; replace the complete assembly, if necessary (see illustration).

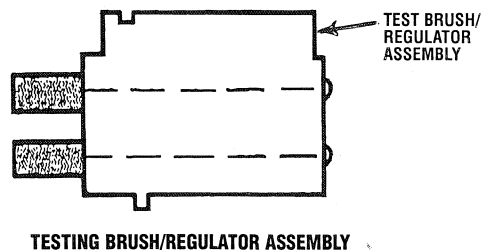

TESTING BRUSH/REGULATOR ASSEMBLY

2. Inspect and test the diode-trio assembly:

a. Using a commercial diode tester, a 12-volt DC test lamp or an ohmmeter, check the resistance between each of the three diode terminals and the indicator light stud (see illustration).

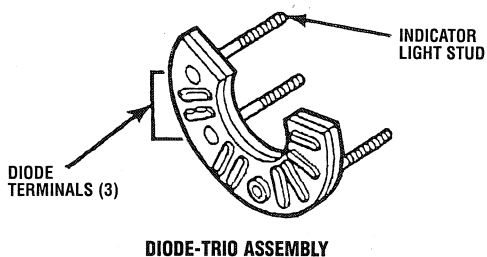

DIODE-TRIO ASSEMBLY

# MANDO ALTERNATOR SERVICE

- b. Reverse the tester leads and repeat the resistance checks.
- c. A very low resistance should be indicated in one direction and a very high resistance should be indicated in the other direction if the diodes are normal.
- d. If any diode appears to be defective, replace the complete assembly. Do not attempt to replace an individual diode.

### 3. Test the diode-rectifier bridge as follows:

- a. Using a commercial diode tester, check for continuity from each of three terminals to the output terminal (see illustration).

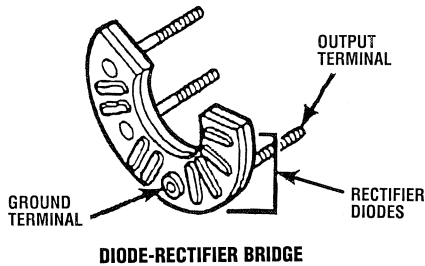

- b. Reverse the tester leads and repeat Step a.
- c. Continuity should exist in only one direction and all diodes should check alike.
- d. Perform the same continuity checks between the three terminals and strap ground terminal. This should show continuity in only one direction through the diodes and all diodes should check alike.
- e. If any diode appears to be defective, replace the rectifier assembly.

### 4. Clean and inspect the front and rear housings:

- a. Inspect the rear housing for cracks or breaks in the casting, stripped threads or a damaged bearing bore. Replace the housing if any of these conditions exist.
- b. Inspect the front housing for cracks, stripped or damaged threads in the adjusting ear, or an out-of-round bore in the mounting foot. If possible, correct slightly damaged threads using a tap. Replace the housing, if necessary.
- c. If the housings are to be reused, clean them in solvent and dry with compressed air.

### 5. Clean and inspect the rotor shaft bearings:

**NOTE:** Do not use a solvent on the rear rotor bearing since it is serviced as a unit with the rotor.

- a. The bearings should be wiped clean with a lint-free cloth containing a moderate amount of commercial solvent. Do not immerse a bearing in solvent, or use pressurized solvent or air.
- b. Check the bearings for obvious damage, looseness or rough rotation. Replace a bearing if any doubt exists as to its condition.

**NOTE:** If the rear rotor bearing needs replacement, replace the entire rotor.

- 6. Inspect the belt pulley for rough or badly worn belt grooves or keyway, and for cracks or breaks. Remove minor burrs and correct minor surface damage; replace a badly worn or damaged pulley.

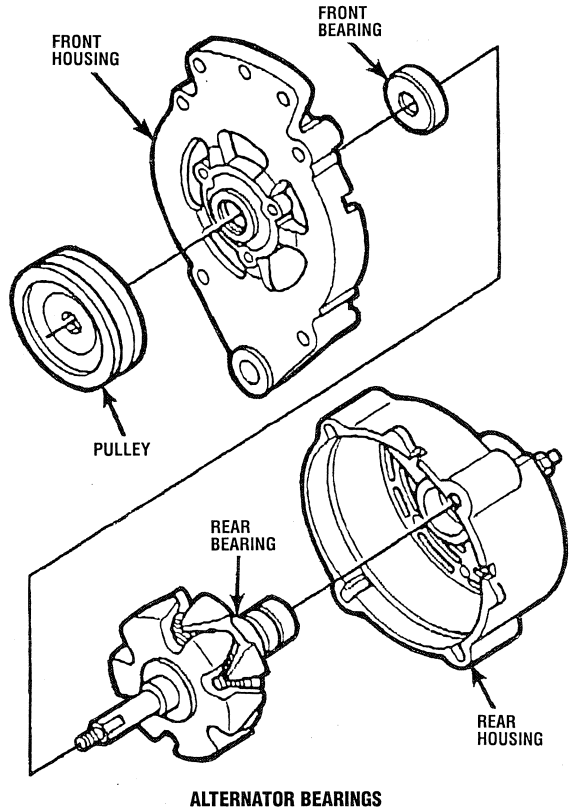

### 7. Test the stator windings as follows:

- a. Using an ohmmeter or test lamp, check for continuity between all three leads (1, 2, and 3). A low ohm reading or lit test lamp should be observed (see illustration).

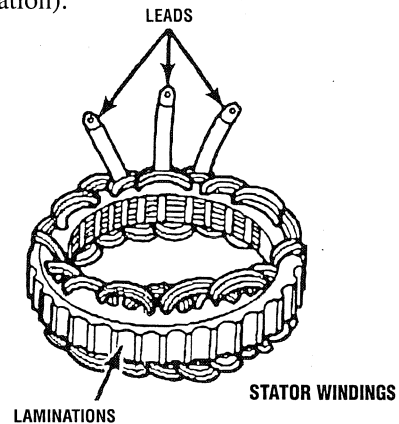

- b. Check the resistance from each lead (1, 2, and 3) to the laminations (4). There should be no continuity if the insulation is good.

# MANDO ALTERNATOR SERVICE

- c. Inspect the stator windings for signs of discoloration. A discolored winding should be replaced.
  - d. If a winding shows a high resistance or an open circuit between any two of the three winding terminals or indicates poor insulation between the windings and the laminations, the stator must be replaced.
8. Check the rotor assembly as follows:

**NOTE:** If slip rings need to be replaced, you must replace the entire rotor.

- a. Visually inspect for physical defects such as damaged shaft threads, worn or damaged bearing areas, burned or pitted slip rings or scuffed pole fingers (see illustration).
- b. Measure the winding resistance across the slip rings (A). Place the ohmmeter leads on the edges of the slip rings, not on the brush contact surfaces. The correct winding resistance at 70 – 80° F (21 – 27° C) is 4.1 to 4.7 ohms (see illustration).
- c. Minor burning or pitting of the slip ring surfaces can be removed using a crocus cloth. Thoroughly wipe the slip rings clean after polishing, removing all grit and dust.
- d. Check for a grounded slip ring or rotor winding by measuring the resistance from each slip ring to the rotor body or pole finger (B). An open circuit should be indicated in both cases for a good rotor (see illustration).

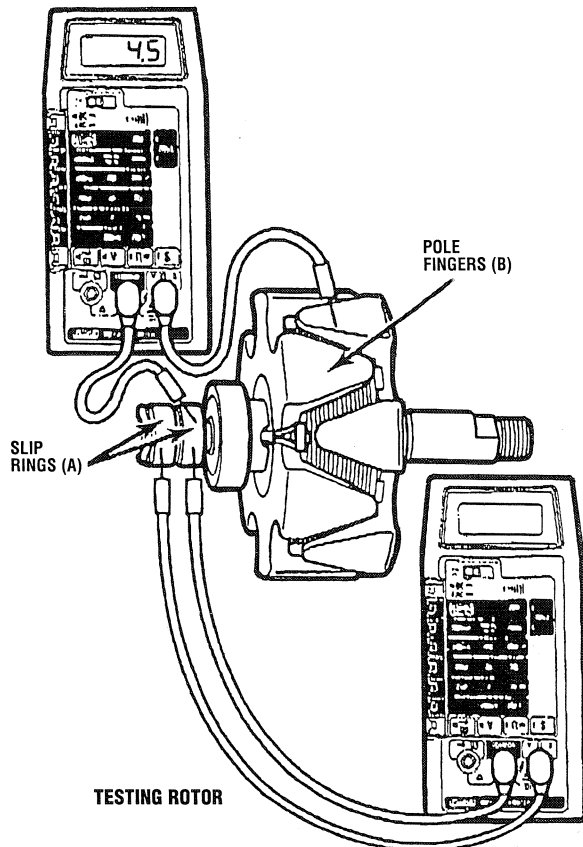

- e. If the windings are defective or physical damage cannot be corrected, replace the rotor assembly.
9. Use a commercial capacitor checker to test the capacitor for capacity, shorts, leakage, and series resistance.

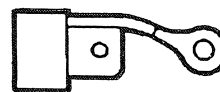

CAPACITOR

## ASSEMBLE ALTERNATOR

1. Carefully press the front bearing into the front housing, pushing against the bearing's outer race using a bearing driver. Lock the bearing in place with screws (see illustration).

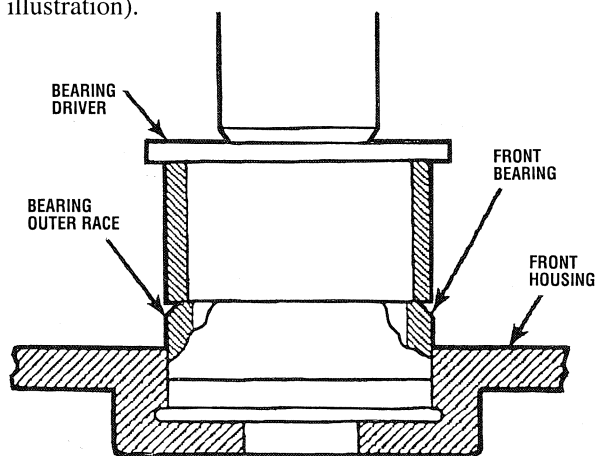

FRONT BEARING INSTALLATION

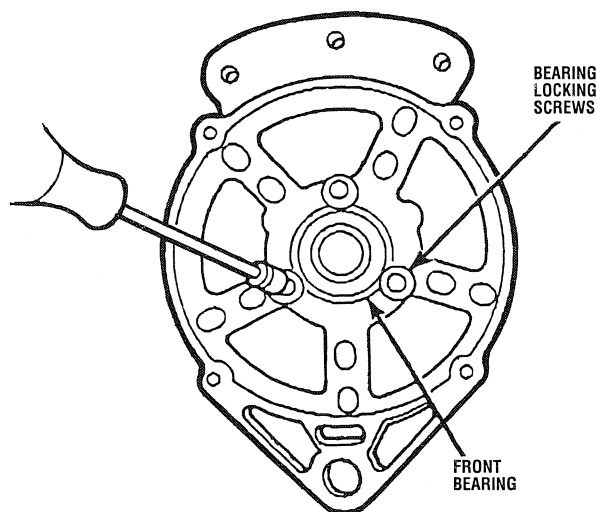

INSTALLING BEARING RETAINERS

2. Place the rotor (pulley end up) on the bed of an arbor press, on two steel blocks.
3. Press the front housing and bearing assembly down onto the rotor shaft. Press against the bearing's inner race only, using a sleeve driver. Take care to insure that the rotor leads clear the steel blocks (see illustration).

# MANDO ALTERNATOR SERVICE

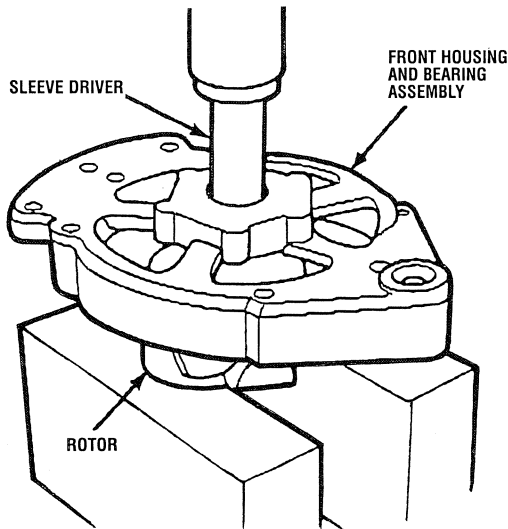

**INSTALLING FRONT HOUSING ON ROTOR ASSEMBLY**

4. Install the rectifier assembly into the rear housing.
5. Insert the Phillips screw and tighten it (see illustration).

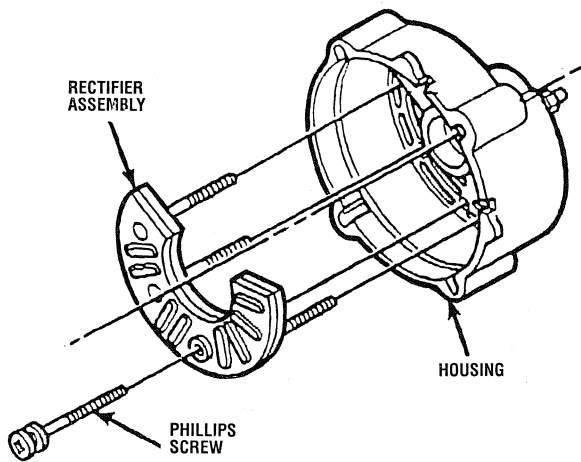

**INSTALLING RECTIFIER ASSEMBLY**

6. Assemble the front and rear housings as follows:
  - a. Put the stator winding in the front housing with the stator leads away from the front housing and the notches in the stator laminations aligned with the four through-bolt holes in the housing.
  - b. Align the scribe marks you made in the stator, and front and rear housings during disassembly.
  - c. Slip the rear housing into place over the rotor shaft. Align the mounting holes and put the stator leads through the holes at the top of the rear housing.
  - d. Install the four bolts and tighten them (see illustration).

**NOTE:** If the front housing is new, the through-bolt will not be tapped.

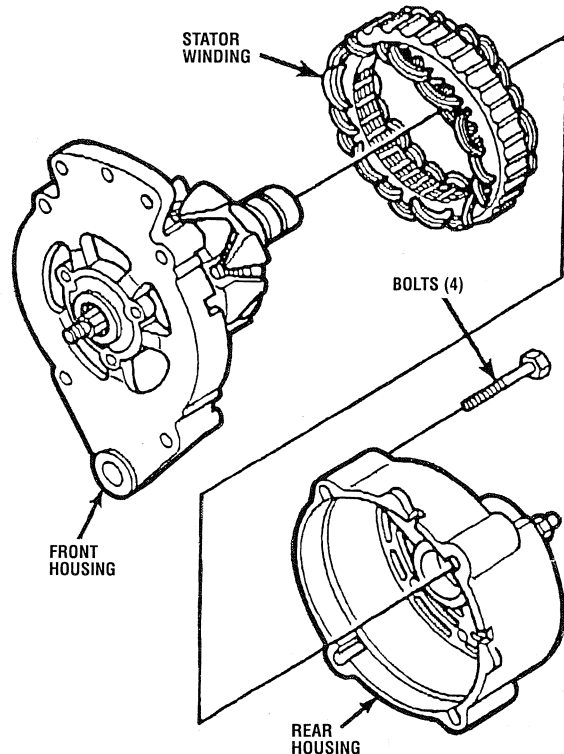

**ASSEMBLING HOUSINGS**

7. Install the spacer and the fan. Then push the pulley, lockwasher and nut onto the shaft. Turn the nut a few turns.

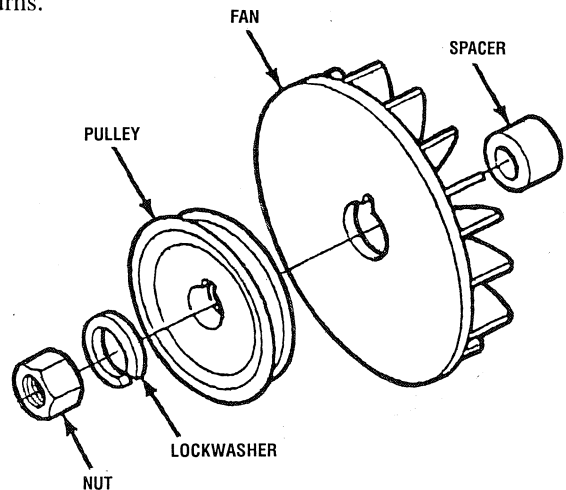

**PULLEY AND FAN COMPONENTS**

# MANDO ALTERNATOR SERVICE

- Place an oversized V-belt around the pulley and fasten the pulley in a vise (see illustration).

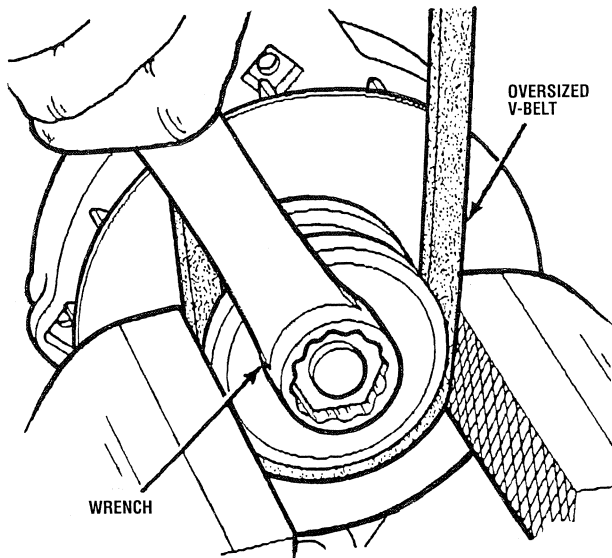

INSTALLING PULLEY AND FAN NUT

- Use a torque wrench to tighten the nut.
- Carefully install the brush/regulator assembly on the rear housing with the two mounting screws.
- Install the small terminal insulators.
- Install the large terminal insulator.
- Install the jumper.
- Install the nut on the terminal.
- Install the brush/regulator assembly cover.
- Install the Phillips screw for the brush/regulator assembly cover.
- Install the capacitor.
- Install the terminal nuts.
- Install the jumper.
- Install the last terminal nut.

## INSTALL ALTERNATOR

- Install the alternator, screws and washers.
- Connect the wiring leads.
- Put the belt on the alternator, crankshaft and coolant pump pulleys.
- Adjust the alternator belt's tension (see *DRIVE BELT ADJUSTMENT* under *ENGINE ADJUSTMENTS*).

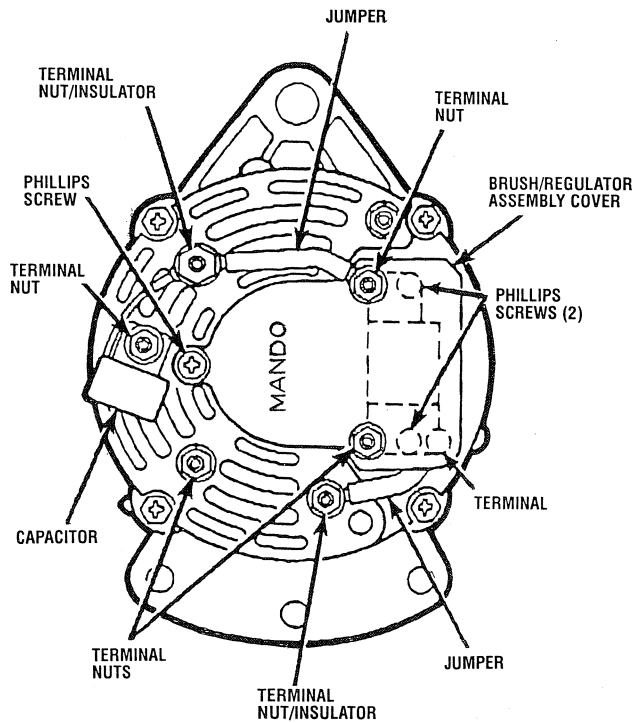

ALTERNATOR ASSEMBLY

## MANDO ALTERNATOR SPECIFICATIONS

Battery Voltage	12 volt
Maximum Speed	13500 rpm
Cut In Speed	Max. 2000 rpm (at Exc.) Max. 1500 rpm (at L2)
Reg. Set Voltage	14.1 volts
Ambient Temperature	-20°C to 100°C
Ground	Negative

# PRESTOLITE ALTERNATOR SERVICE

## GENERAL

The charging system consists of an alternator with a mounted voltage regulator, an engine DC wiring harness, a mounted DC circuit breaker, and a battery and connection wires. Because of the use of integrated circuits (IC's) the electronic voltage regulator is very compact and is mounted internally or on the back of the alternator.

It is desirable to test the charging system (alternator and voltage regulator) in the boat using the wiring harness and electrical loads that are a permanent part of the system. In-boat testing will then provide the technician with an operational test of the charging system as well as the major components of the electrical system.

## PRELIMINARY CHECKS AND TESTS

Before starting the actual alternator and voltage regulator test procedures, the charging system, batteries and wiring should be checked to eliminate possible problem areas. The following checks are recommended:

**⚠ WARNING:** *A failed alternator can become very hot. Do not touch until the alternator has cooled down.*

1. Make certain your alternator is securely mounted.
2. Check the drive belt for proper tension. Replace the belt if it is worn or glazed.
3. Check that all terminals, connectors and plugs are clean and tight. Loose or corroded connections cause high resistance and this could cause overcharging, undercharging or damage to the charging system. Badly corroded battery cables could prevent the battery from reaching a fully charged condition.
4. Check the condition of the battery and change if necessary. A low or discharged battery may cause false or misleading readings on the in-vessel tests.

**NOTE:** *An isolator with a diode, a solenoid, or a battery selector switch is usually mounted in the circuit to isolate the batteries so the starting battery is not discharged along with the house batteries. If the isolator is charging the starting battery but not the house battery, the alternator is OK and the problem is in the battery charging circuit.*

**⚠ WARNING:** *Shut off the engine battery switch or disconnect from the battery when working on the engine electrical system.*

## Test Equipment Requirements

The alternator and regulator tests described in this section require electrical test equipment to measure voltage only; however, most commercial test equipment incorporates several testing devices in a single unit. The following test equipment will be necessary:

DC VOLTMETER: 0–20 volt scale

HYDROMETER: Any commercial type having a temperature correction scale.

## Storage Battery

The starting battery circuit supplies a continuous, although variable, electrical load to the alternator. If the circuit, positive or negative, is opened or broken while the alternator is charging, the loss of the battery will result in the charging voltage rising to unsafe levels.

## Battery Inspection

The following table illustrates typical ranges of specific gravity for a cell in various states of charge. *The battery must be at least 75% of full charge for effective alternator testing.*

1.260 SPECIFIC GRAVITY BATTERY	1.280 SPECIFIC GRAVITY BATTERY	CHARGE STATE
1.260 Specific Gravity	1.280 Specific Gravity	100% Charged
1.230 Specific Gravity	1.250 Specific Gravity	75% Charged
1.200 Specific Gravity	1.220 Specific Gravity	50% Charged
1.170 Specific Gravity	1.190 Specific Gravity	25% Charged
1.140 Specific Gravity	1.160 Specific Gravity	Very Low Capacity
1.110 Specific Gravity	1.130 Specific Gravity	Discharged

After completing these preliminary checks and tests, proceed with the tests as outlined in the *TROUBLESHOOTING GUIDE*.

## Checking for Proper Voltage

If you suspect the alternator has failed, perform the following tests with the engine off:

1. Using a voltmeter, connect the voltmeter red wire clip to the output terminal B+.
2. Connect the voltmeter negative wire to any ground on the engine.
3. Check the battery voltage. It should read 12 to 13 volts.
4. Check the voltage between the alternator (+) positive terminal B and any engine ground. If the circuit is good, the voltage at the alternator should be the same as the battery (unless there's an isolator in the circuit, then the reading would be zero).

**⚠ CAUTION:** *To avoid damage to the battery charging circuit, never shut off the engine battery switch when the engine is running!*

**⚠ WARNING:** *Before starting the engine make certain that everyone is clear of moving parts! Keep away from sheaves and belts during test procedures.*

5. Start the engine.



# PRESTOLITE ALTERNATOR SERVICE

- The voltage reading for a properly operating alternator should be between 13.5 and 14.5 volts. If your alternator is over- or undercharging, have it repaired at a reliable service shop.

**NOTE:** Before removing the alternator for repair, use your voltmeter to ensure that 12 volts DC excitation is present at the R terminal if the previous test showed only battery voltage at the B output terminal.

## ALTERNATOR DESCRIPTION

The stator is connected to a three-phase, full-wave bridge rectifier package which contains six diodes. The bridge converts the AC generated in the stator to a DC output for battery charging and accessories such as radio, heater, lights, refrigerator, depth sounder, etc. See the illustrations below.

Power to the regulator and the field of the integral regulator alternator is provided by the field diode (or diode trio) package contained in the alternator.

The alternator designs produce a rated output of 51 amperes. Rated output is achieved at approximately 6000 alternator rpm at an ambient temperature of 75°F (23.8°C). The alternator is designed to operate in an ambient temperature range of -40° to 212°F (-40° to 100°C). To ensure proper cooling of the rectifier bridge and internal components of the alternator, it must be used with the proper cooling fan.

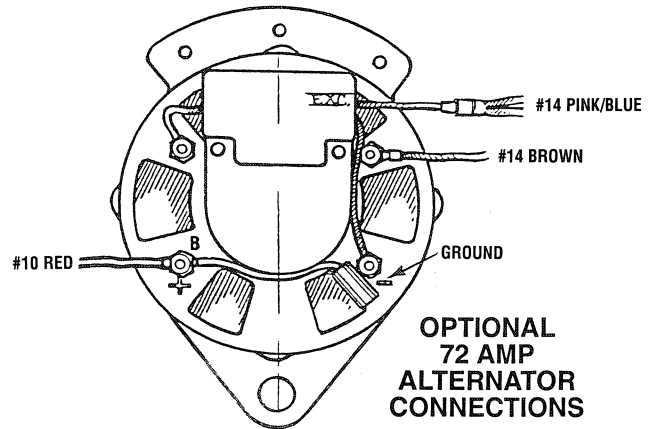
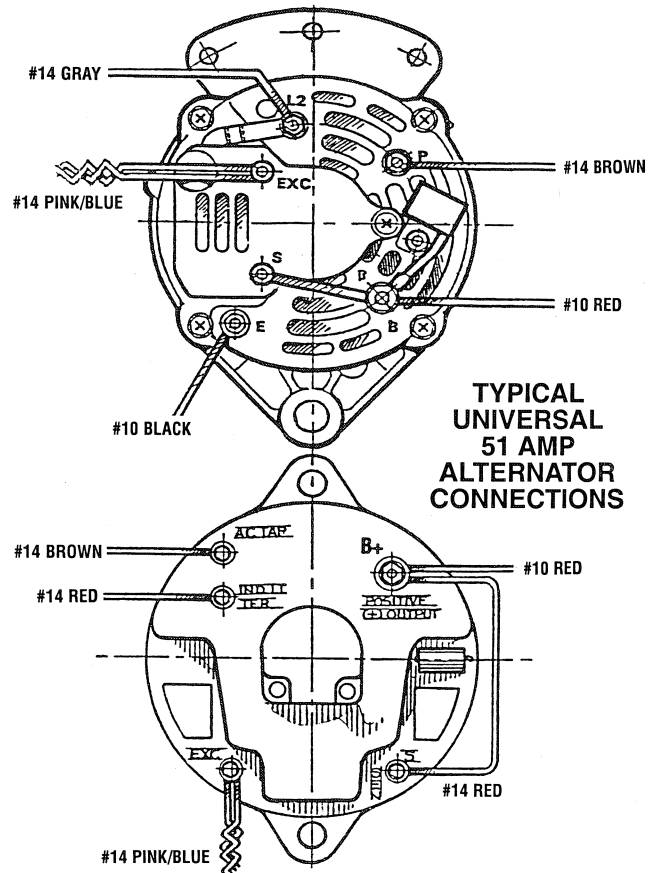
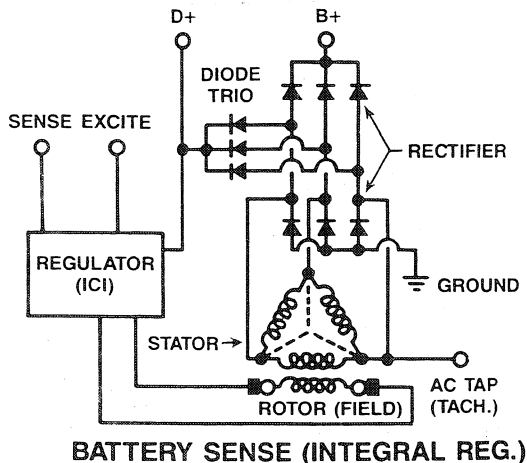
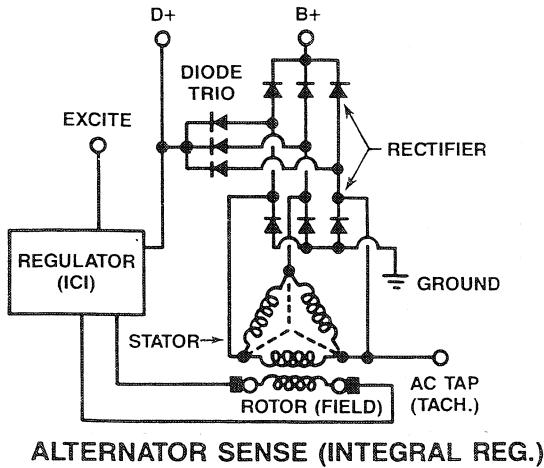

## VOLTAGE REGULATOR

The integral voltage regulator is an electronic switching device which senses the system voltage level and switches the voltage applied to the field in order to maintain a proper system voltage.

The regulator design utilizes all-silicon semi conductors and thick-film assembly techniques. After the voltage has been adjusted to the proper regulating value, the entire circuit is encapsulated to protect the circuit and the components from possible damage due to handling or vibration and moisture encountered in a vessel.

# PRESTOLITE ALTERNATOR SERVICE

The voltage regulator is also temperature compensated to provide a slightly higher voltage at low temperatures and a lower voltage at higher temperatures, to provide for the charging requirements of the battery under these conditions.

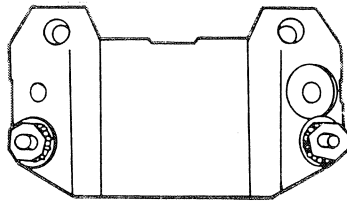

**INTEGRAL REGULATOR**

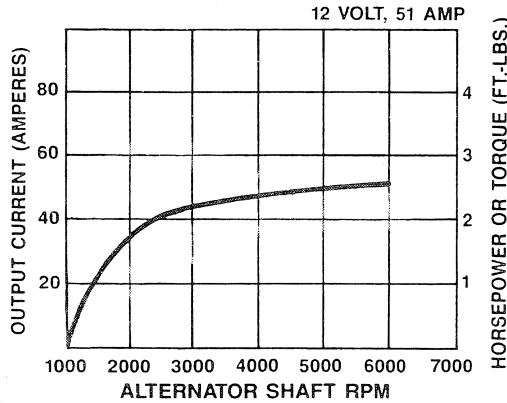

**TYPICAL PERFORMANCE CURVE  
@ AMBIENT TEMPERATURE OF 75°F  
(23.8°C) SAE TEST METHOD**

## TESTING PROCEDURE

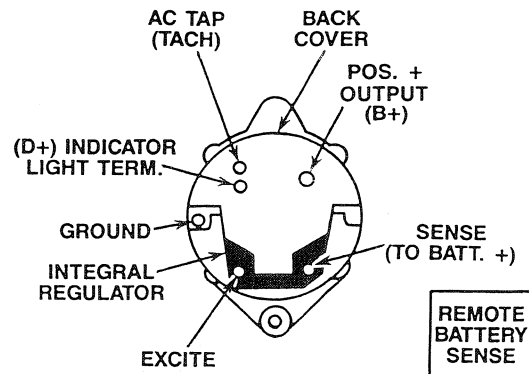
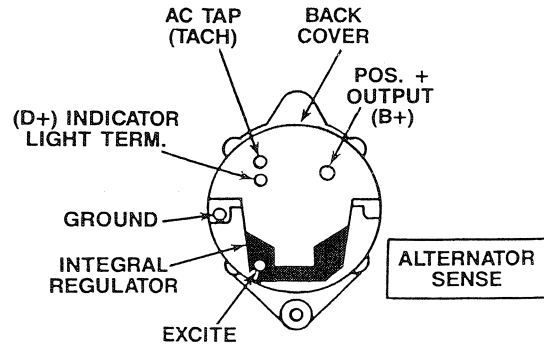

**ALTERNATOR TERMINAL IDENTIFICATION**

## TROUBLESHOOTING GUIDE

PROBLEM	PROBABLE CAUSE	CORRECTIVE ACTION
<b>A.</b> Battery undercharged. — Ammeter (if used) indicates constant discharge. — Indicator lamp remains on.	1. Defective cables, dirty battery posts, corroded terminals, etc. 2. Loose or broken belt. 3. Worn or broken brushes. 4. Defective alternator system.	1. Check, clean, repair or replace as needed. 2. Check belt. 3. Replace brush assembly. 4. Refer to <i>LOCATING THE PROBLEM</i> section.
<b>B.</b> Battery undercharged. — Indicator lamp off with key on and engine stopped. (Normal condition is lamp on.)	1. Indicator lamp burned out or defective wire harness. 2. Broken brush. 3. Defective alternator system.	1. Check bulb and harness. 2. Replace brush assembly. 3. Refer to <i>LOCATING THE PROBLEM</i> section.
<b>C.</b> Battery overcharges. — Excessive use of water. — Ammeter (if used) shows constant excessive charge. — Voltmeter indicates greater than 14.5 volts (connected across battery with no load) with engine idling.	1. Defective wire harness. 2. Defective alternator system. 3. Poor ground. 4. Broken sense lead (remote battery sense only).	1. Refer to <i>LOCATING THE PROBLEM</i> . 2. Refer to <i>LOCATING THE PROBLEM</i> . 3. Check ground. 4. Check, clean, repair or replace as needed.
<b>D.</b> Battery charges at idle, but discharges under load conditions.	1. Slipping belt. 2. Alternator defective.	1. Check belt and adjust tension or replace as necessary. 2. Disassemble, check diodes.
<b>E.</b> Indicator lamp glows slightly under moderate load; battery appears charged.	1. Defective diode-trio.	1. Remove and replace.

# PRESTOLITE ALTERNATOR SERVICE

## LOCATING THE PROBLEM

**NOTE:** The engine must be idling for all tests unless otherwise specified.

### A. BATTERY UNDERCHARGED

1. Remove battery sense only.
  - a. Perform the Harness Voltage Test (Test No. 3).
2. Indicator lamp on.
  - a. Perform the Open Diode-Trio Test (Test No. 1).
3. Indicator lamp off (ignition on, and engine stopped).
  - a. Perform Regulator Test (Test No. 2).
  - b. If the regulator is OK, the cause is probably an open field circuit, and the alternator must be removed for repair.
4. Further investigation requires alternator removal and repair (diodes).

### B. BATTERY OVERCHARGED

1. Regulator shorted; replace regulator.

## Alternator/Regulator Tests

### Test No. 1—Open Diode-Trio Test

With the ignition on and the engine not running and the jumper not attached (no electrical load), check for battery voltage at terminal A and for 1.5 to 3.0 volts at terminal B. Add jumper JU1 between terminals A and B. Start the engine and run at idle. If the indicator lamp now goes off and charging voltage is present at terminal A, the diode-trio is probably "open" (defective) and the alternator should be removed for repair.

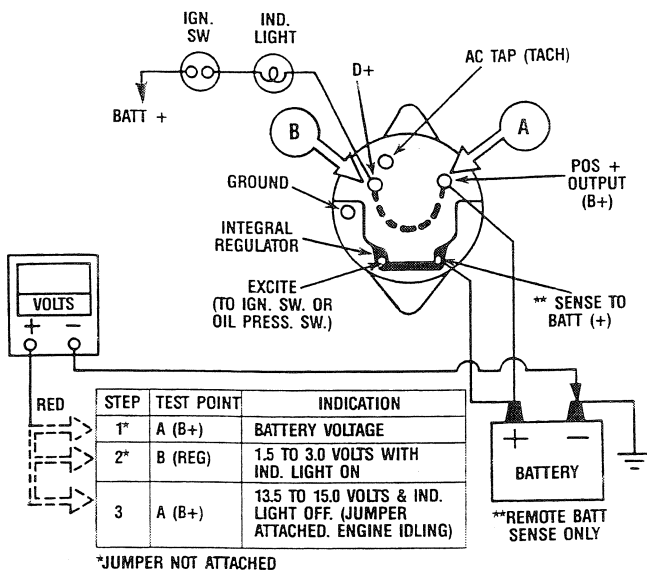

OPEN DIODE-TRIO TEST

### Test No. 2—Open Regulator Test

**NOTE:** This test requires the removal of the back cover of the alternator. To remove, disconnect the wires from the terminals extending through the back cover. Remove the back cover (two screws) and reconnect all wires.

With the ignition on and the engine not running and the jumper not attached, check for battery voltage at terminal A and terminal B. The indicator light will be off. Add jumper JU1 between the field and ground. If 1.5 to 3.0 volts is present at terminal B and the indicator light is on, an open (defective) regulator is indicated. If the lamp is still not on, an open field circuit (brushes, slip-rings, etc.) is indicated and alternator repair is required.

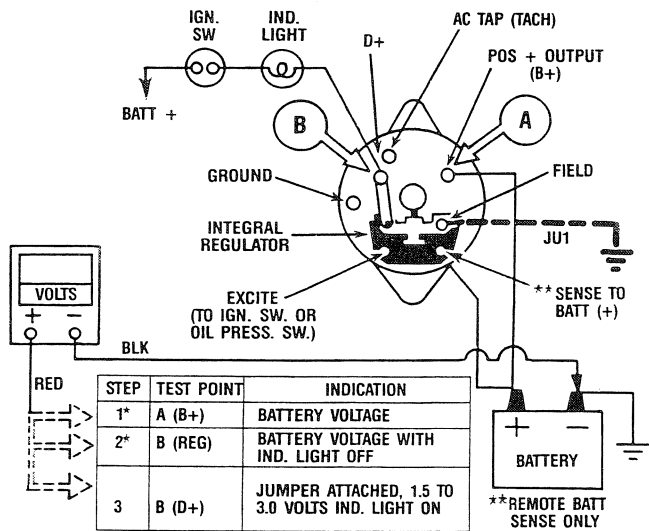

REGULATOR TEST (BACK COVER REMOVED)

### Test No. 3—Harness Voltage Test (remove battery sense only)

Remove the harness sense lead from the sense terminal and connect the voltmeter leads as shown in the illustration. The voltmeter should indicate the battery voltage (approx. 12.6 volts for a fully charged battery with the ignition key off). If the voltage is zero, the harness "sense" lead is open and should be repaired or replaced.

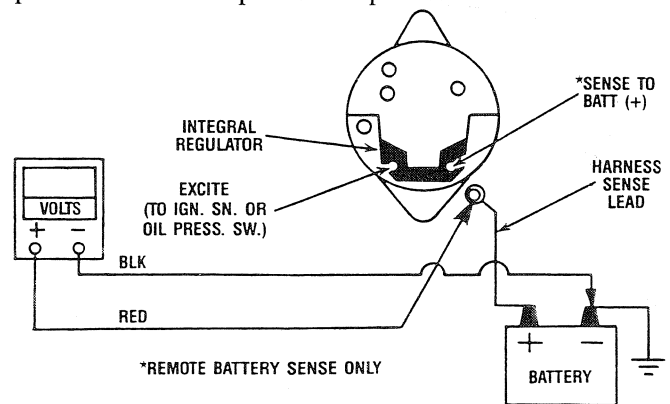

CABLE HARNESS VOLTAGE TEST

# PRESTOLITE ALTERNATOR SERVICE

## Test No. 4—Alternator Output Test

After the voltmeter is connected as shown in the illustration, start and run the engine at a fast idle of approximately 1,500 rpm. Check for a nominal system output voltage of between 13.8-14.8 volts for a properly operating charging system. (Voltages may vary a few tenths of a volt (higher or lower) due to ambient temperature variations).

If the alternator output voltage does not fall within the proper range, the alternator should be disassembled for further inspection and tests.

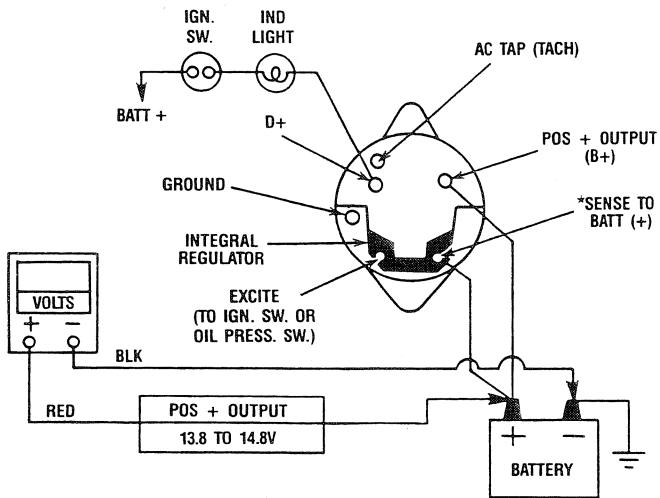

\*REMOTE BATTERY SENSE ONLY

ALTERNATOR OUTPUT TEST

## ALTERNATOR REPAIR PROCEDURE

The following instructions provide a general overall procedure for the complete disassembly of an alternator. However, it should be pointed out that following the complete procedure whenever a repair is necessary will seldom, if ever, be required. In cases where the causes of the malfunction are known, it will only be necessary to follow that portion of the procedure directly related to resolving the problem. Similarly, when the reasons for the malfunction are uncertain, it will be necessary to follow the procedure in greater depth in order to isolate and correct the problem.

The following troubleshooting diagram should help identify some of the more common problems encountered during the overhaul/repair procedure.

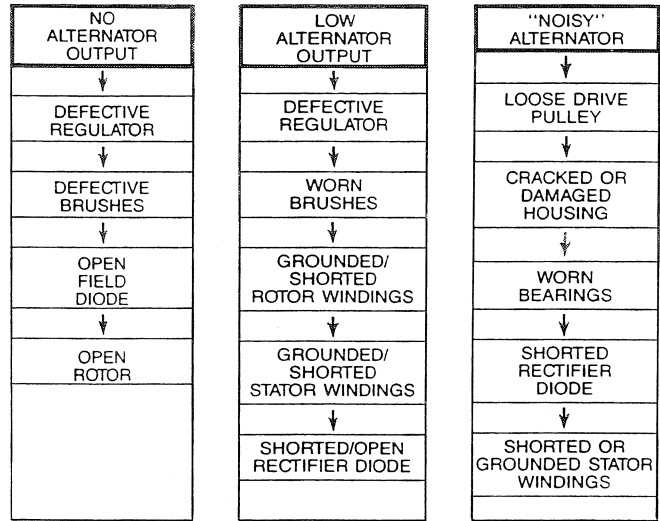

ALTERNATOR TROUBLESHOOTING DIAGRAM

## ALTERNATOR DISASSEMBLY & TESTING

### 1. Detach the back cover:

Remove the nuts from the terminals. Remove the two screws that secure the back cover to the rear housing.

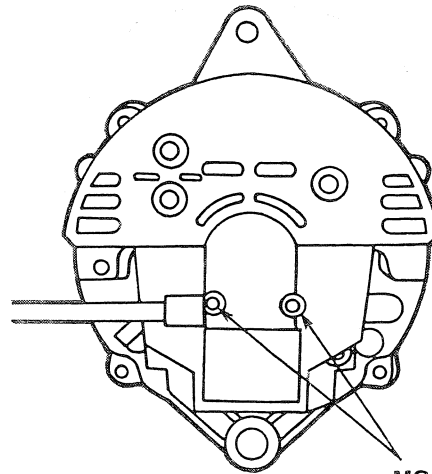

BACK COVER MOUNTING SCREWS (2)

REMOVING BACK COVER

# PRESTOLITE ALTERNATOR SERVICE

## 2. Remove the brush holder:

Remove the two locknuts securing the brush holder. Pull out the brush holder (see illustration).

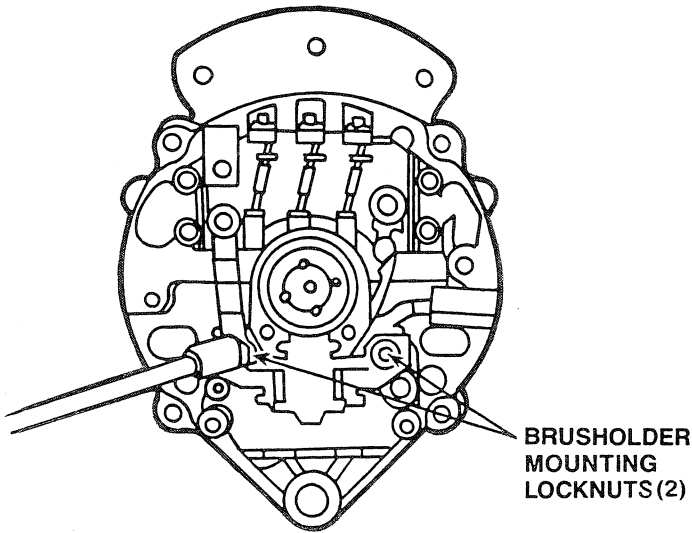

REMOVING BRUSH HOLDER

## 4. Remove the integral voltage regulator:

Remove the two screws securing the integral voltage regulator to the rear housing.

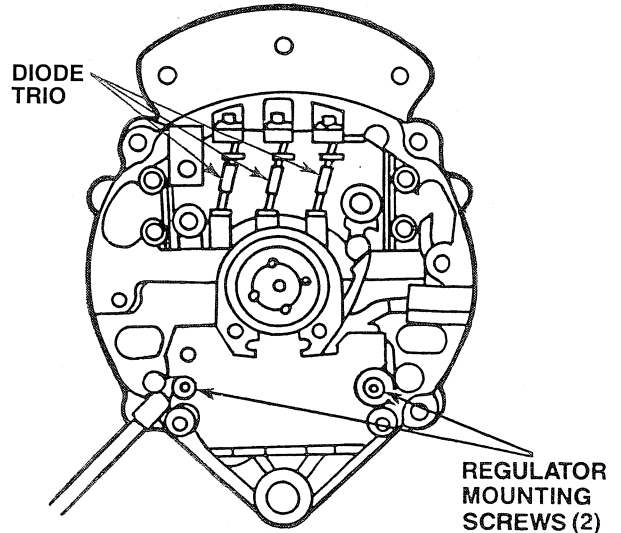

REMOVING VOLTAGE REGULATOR

## 3. Inspect and test the brush assembly:

The illustration below shows the terminal's brush arrangement and testing procedure. The original brush set may be reused if the brushes are 3/16 in. (5 mm) or longer, and if the brushes are not oil soaked, cracked or show evidence of grooves on the sides of the brushes caused by vibration.

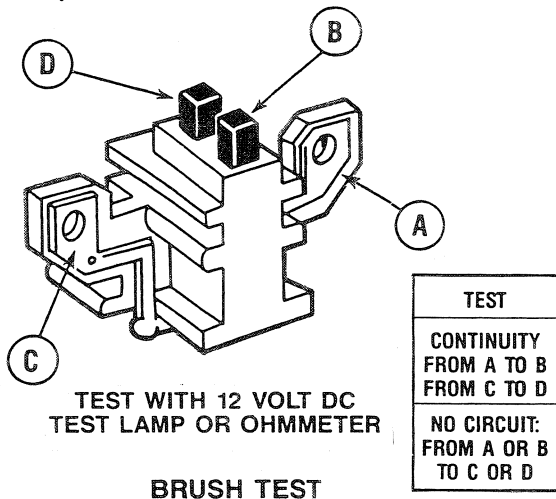

BRUSH TEST

## 5. Remove the diode-trio (field diode) and rectifier diode bridge:

The diode-trio and rectifier diode bridge are detached as an assembly. Remove the cone lockout from the positive output (B+) terminal. Straighten the B+ strap. Remove the three terminal screws and the four diode-trio mounting screws. Detach the assembly from the rear housing and separate the diode-trio assembly from the rectifier bridge (see illustration).

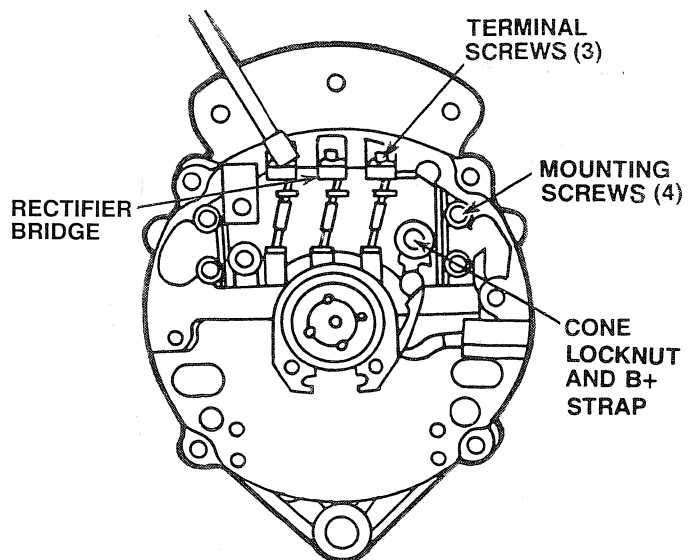

REMOVING DIODE-TRIO AND  
RECTIFIER DIODE BRIDGE

# PRESTOLITE ALTERNATOR SERVICE

## 6. Test the diode-trio assembly:

Using a commercial diode tester or 12 volt DC test lamp, check for continuity from each terminal separately to the D+ stud; continuity should be observed in one direction (polarity) only, and all diodes should check alike. If any diode is defective, replace the entire diode trio assembly. See illustration.

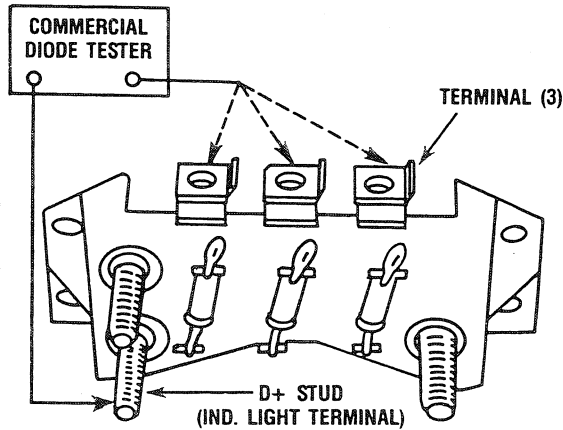

TESTING DIODE-TRIO

## 7. Test the diode rectifier bridge assembly:

Using a commercial diode tester, check for continuity. Check between point A and each of the three terminals C for negative diodes. Continuity should be observed in one direction (polarity) only, and all diodes should check alike. Then check between point B (B+ strap) and each of three terminals C for positive diodes. Continuity should be observed in one direction only, and all diodes should check alike (see illustration).

If any diode is defective, replace the entire diode rectifier bridge assembly.

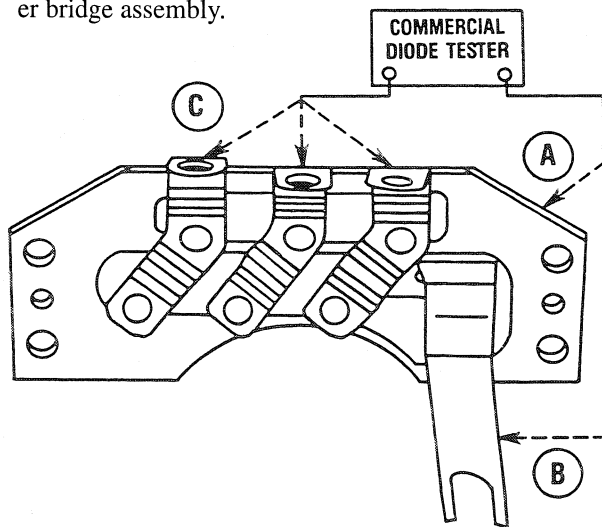

TESTING RECTIFIER BRIDGE

## 8. Separate the stator/rear housing assembly from the front housing:

Remove the four thru-bolts (see illustration).

Carefully insert two screwdriver blades in opposite openings between the stator and the front housing as shown in the illustration. Pry the units apart.

**CAUTION:** Do not insert the screwdriver blades deeper than 1/16 in. (1.5 mm) to avoid damaging the stator winding.

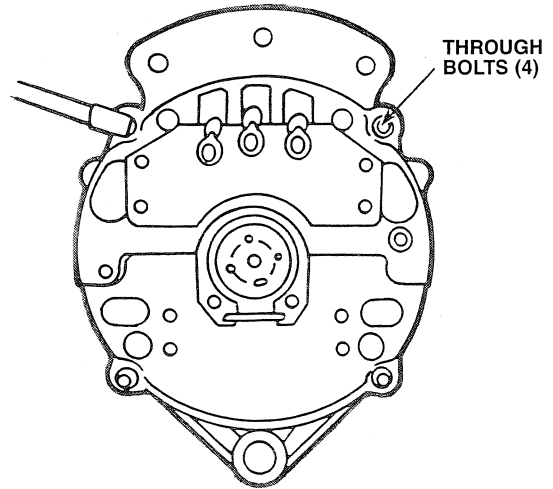

THRU-BOLT REMOVAL

SCREWDRIVER BLADES AT OPPOSITE OPENINGS

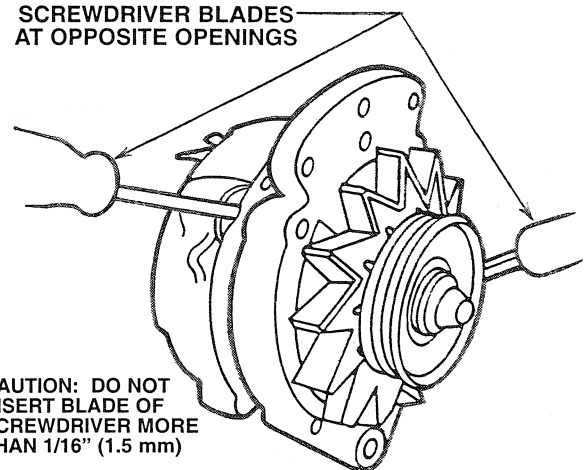

**CAUTION:** DO NOT INSERT BLADE OF SCREWDRIVER MORE THAN 1/16" (1.5 mm)

STATOR-REAR HOUSING SEPARATION

## 9. Inspect the rear housing:

Inspect the rear housing for a cracked or broken casting, stripped threads or evidence of severe wear in the bearing bore due to a worn rear bearing.

If the casting is to be reused, clean it in solvent, dry with compressed air, and install a new rear bearing retainer if the retainer is damaged.

# PRESTOLITE ALTERNATOR SERVICE

## 10. Test the stator:

The stator assembly consists of three individual windings terminated in the delta type connections. Using an ohmmeter or a test lamp, check for winding continuity between terminals A, B and C. There should be no continuity from any terminal to point D (laminations). Also, stators showing any signs of winding discoloration should be discarded (see illustration).

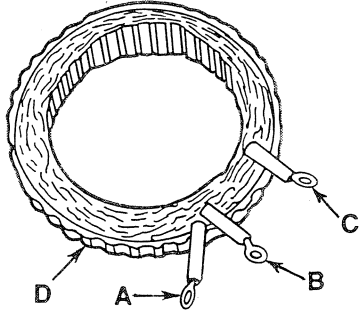

STATOR WINDING TESTS

## 11. Remove the pulley, fan and spacer:

The pulley is a slip-fit on the rotor shaft, positioned with a woodruff key. Remove the nut and lockwasher from the shaft using an impact wrench or other suitable tool.

After the nut and lockwasher are removed, the alternator can be separated from the pulley.

The fan will slide over the key. The key may be removed with diagonal pliers, or with a screwdriver.

Inspect the fan for cracked or broken fins, and note the condition of the mounting hole. If it is worn from running loose, replace the fan to insure balance.

Inspect the pulley for possible faults as shown in the illustration.

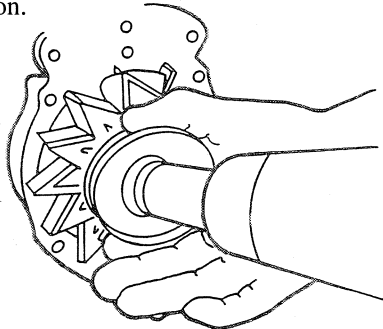

PULLEY REMOVAL

CHECK FOR WORN DRIVE SURFACES.

CHECK FOR POLISHED SURFACE HERE.

NOTE CONDITION OF KEY GROOVE.

CHECK BORE FOR WEAR.

PULLEY INSPECTION POINTS

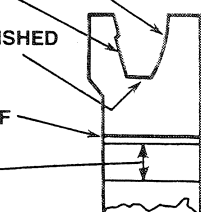

## 12. Separate the rotor from the front housing:

Position the front housing on support blocks placed on an arbor press. Push the rotor assembly from the housing (see illustration).

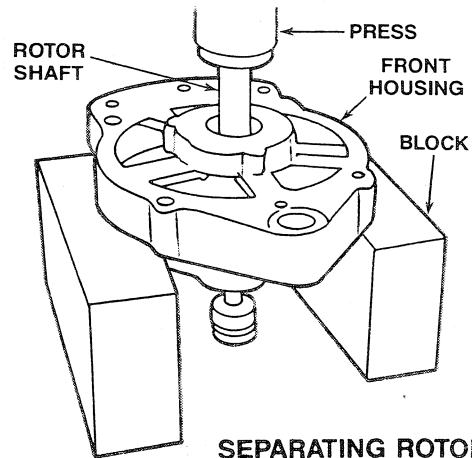

SEPARATING ROTOR FROM FRONT HOUSING

## 13. Remove the front bearing from the housing:

Remove the three bearing retainer screws. Position the housing on support blocks placed on an arbor press. Using a tool that contacts the inner race of the bearing, press out the front bearing (see illustrations).

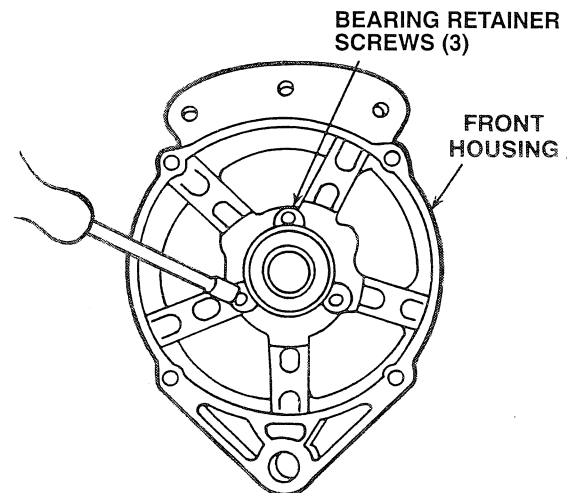

REMOVING RETAINER SCREWS

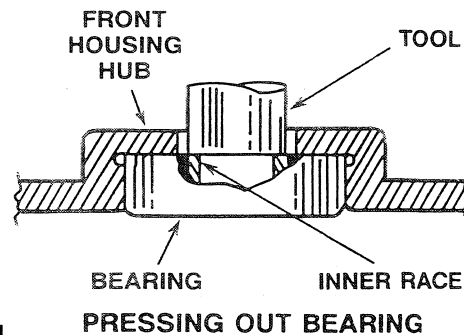

PRESSING OUT BEARING

# PRESTOLITE ALTERNATOR SERVICE

## 14. Inspect the front housing:

Check the housing for cracks. Check the condition of the threads in the adjusting ear. Check the bore in the mounting foot. Discard the housing if the bore shows signs of elongation (oval or out-of-roundness).

## 15. Rotor inspection & electrical testing:

Check the rotor assembly for the following electrical properties (see illustration).

### A. Current draw or resistance of the winding.

**CAUTION:** Turn off the DC power source before removing the test leads to avoid arc damage to the slip ring surfaces.

1. Current Draw in amperes, at 70°–80°F (21°–27°C):

12 Volt Models, Rated At:	Correct Current Draw @ 15.0 V:
51 Amperes	3.2–3.6 Amperes

2. Resistance of winding in Ohms, at 70°–80°F (21°–27°C):

12 Volt Models, Rated At:	Correct Winding Resistance:
51 Amperes	4.1–4.7 Ohm

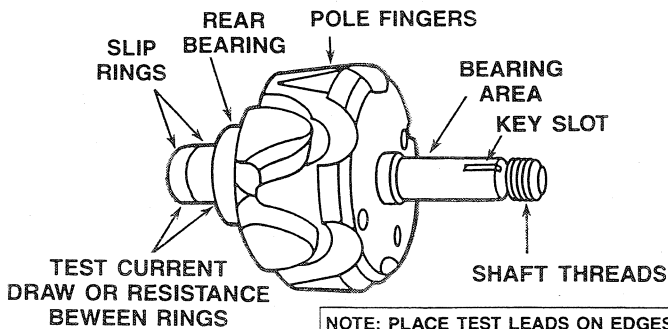

NOTE: PLACE TEST LEADS ON EDGES OF SLIP RINGS TO AVOID CREATING ARCS ON BRUSH CONTACT SURFACES.

## ROTOR INSPECTION AND ELECTRICAL TESTING

### B. Grounded slip ring or winding.

Use a 12 volt DC test lamp, ohmmeter, or 110V AC test lamp. Place one test lead to the rotor body and the other on either slip ring. An open circuit from either slip ring to the rotor body is a correct condition.

### C. Condition of the slip rings.

1. Clean the brush contacting surfaces with a fine crocus cloth; wipe the dust and residue away.
2. If surfaces are worn beyond this restoration, replace the entire rotor assembly.

### D. Rotor shaft and pole pieces.

1. Stripped threads on shaft.
2. Worn key slot.
3. Worn bearing surface.
4. Scuffed pole fingers.
5. Worn or dry rear bearing.

Replace the rotor assembly if any of the above faults are noted, with the exception of item D, 5.

**NOTE:** New rotors include a new rear bearing and new slip rings as part of the assembly. If the rear bearing requires replacement, follow the instructions for this operation.

## 16. Remove the slip rings from the rotor assembly:

Unsolder the rotor leads from the slip ring terminals. Carefully unwind the ends of the rotor coil leads from the slip ring terminals, as shown in the illustration.

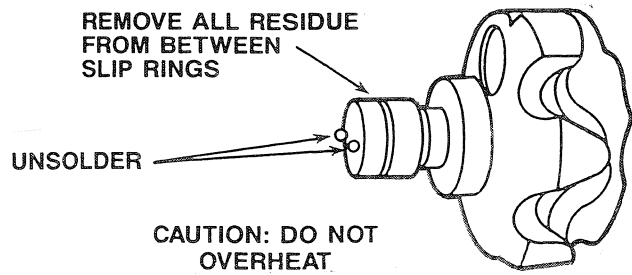

## UNSOLDER ROTOR LEADS FROM SLIP RINGS

Straighten the rotor leads. Insert a No. 10 x 1" cap screw into the opening at the center of the slip ring assembly. Position the bearing puller as shown in the illustration and pull the slip ring assembly off the rotor shaft.

**CAUTION:** When holding the rear end of the rotor shaft in a vise, be sure not to grip the bearing area of the rotor shaft.

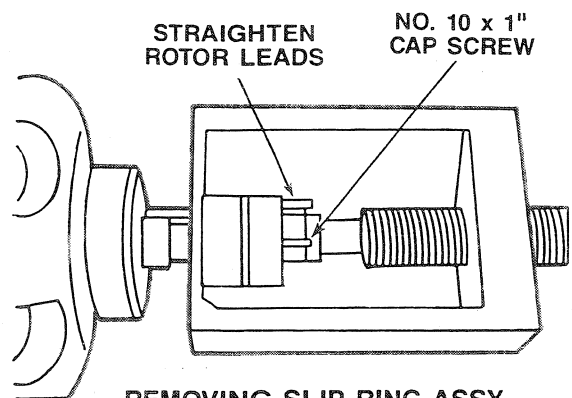



# PRESTOLITE ALTERNATOR SERVICE

## 17. Remove the rear bearing from the rotor:

Dress the rotor leads away from the bearing puller contact area. Adjust the puller to contact the inner bearing race, then carefully remove the bearing from the shaft (see illustration).

This completes the disassembly of the alternator.

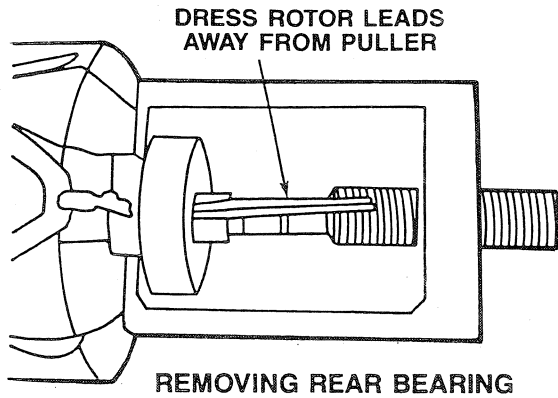

## ALTERNATOR REASSEMBLY

The reassembly sequence, generally, is the reverse of the order of disassembly, therefore, only information pertaining to special reassembly requirements will be covered in this section.

### 1. Install the rear bearing:

Place the rotor on a press as shown in the illustration. Choose a driver sleeve that exerts pressure on the inner race only, and press the bearing onto the rotor shaft until it contacts the shoulder. New replacement bearings should be used whenever the bearing is removed during repair procedures or when the bearing is rough, dry or noisy.

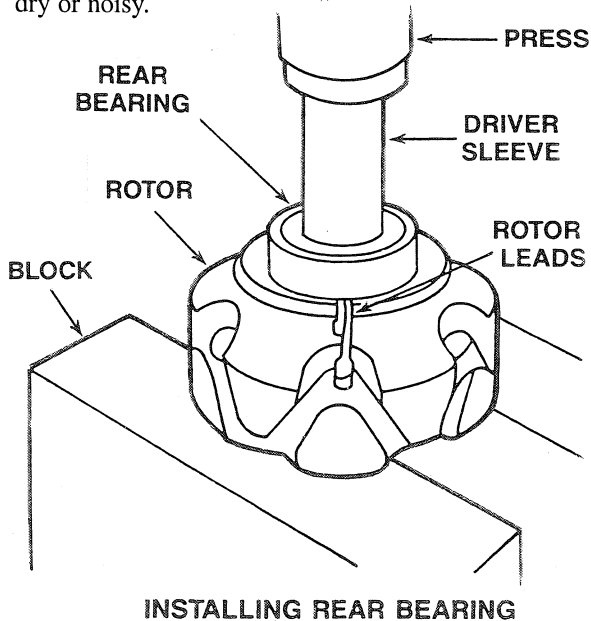

### 2. Install the slip ring assembly:

Guide the rotor leads through one of the oval passages in the slip ring assembly. Be sure the oval passage is in line with the groove in the rotor shaft. Place the rotor on a press as shown in the illustration. Choose a driver sleeve having a diameter that clears the leads.

Press the slip ring assembly onto the shaft. Solder the rotor leads to the leads on the slip ring. Trim excess slip ring leads extending above the solder connections.

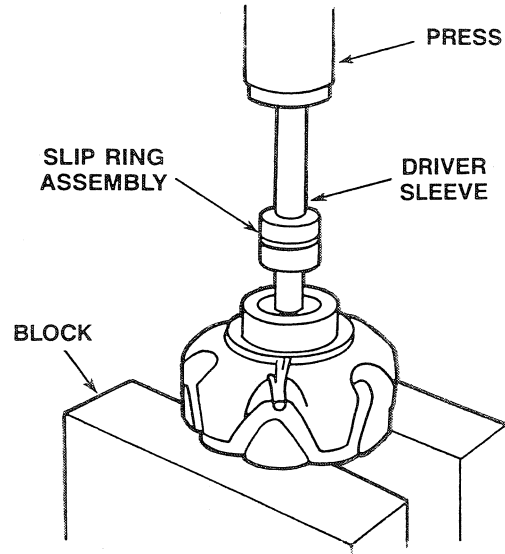

### 3. Install the front bearing:

Place the front bearing and housing in an arbor press as shown in the illustration. Select a drive tool to contact the outer race only, and press the bearing into the housing bore. Bearing replacement is recommended whenever a bearing is removed during alternator repair procedures or when the bearing is rough, dry or noisy. Install three bearing retainer screws. Torque to 25–30 ft-lbs (33.9–40.7 Nm).

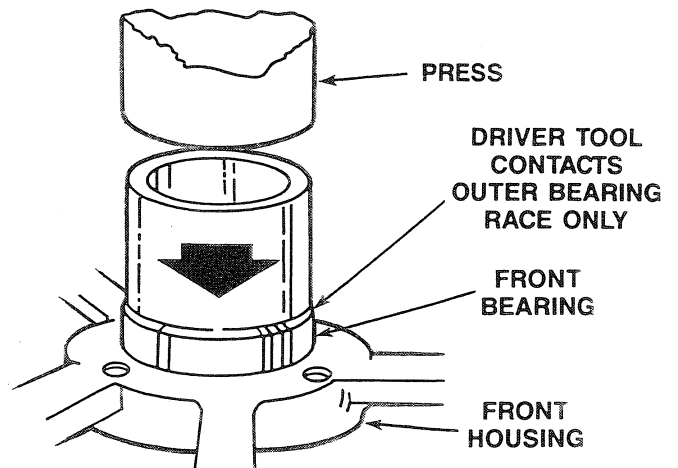

# PRESTOLITE ALTERNATOR SERVICE

## 4. Assemble the rotor and front housing:

Place the rotor on the bed of an arbor press using two steel blocks for support, as shown in the illustration. Place the front housing over the shaft. Using a driver sleeve that contacts the inner bearing race only, press the front housing down until the inner bearing race contacts the shoulder on the shaft.

**CAUTION:** Be sure the rotor leads clear the blocks.

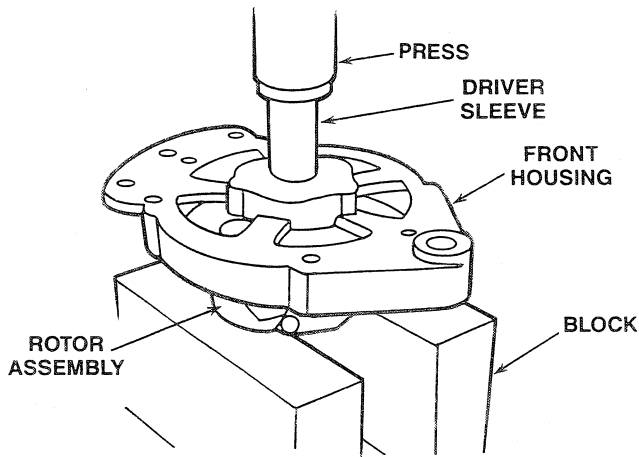

ASSEMBLING FRONT HOUSING TO ROTOR

## 5. Assemble the spacer, fan and pulley:

Place the pulley spacer over the shaft. Install the woodruff key. Install the fan. Install the pulley, lock washer and nut. Mount the pulley as shown in the illustration and tighten to 35–50 ft-lbs (47.5–67.8 Nm).

Spin the rotor by hand to test the freedom of the bearing.

## 6. Assemble the front and rear housings:

Place the stator into the front housing with the stator leads at the top and the notches in the laminations aligned with the bolt holes. Position the rear housing over the slip rings with the housing bolt holes aligned and the stator leads extending through the openings at the top of the rear housing.

Install the through-bolts and tighten them evenly to 50–60 in-lbs (5.7–6.8 Nm). Spin the rotor by hand to test the freedom of the bearings.

**NOTE:** New front housings contain through-bolt holes that are not tapped. Therefore, a socket wrench rather than a nut driver will be required to supply sufficient torque to drive the “thread forming” through-bolts.

## 7. Install the diode rectifier bridge and diode trio:

Insert the B+ strap through the slot in the diode trio body. Bend the strap over the B+ terminal and secure it with a cone locknut. Apply a thin film of heat sink

compound to the back of the diode rectifier bridge and to the mating area on the rear housing.

Install the assembly to the rear housing (four screws). Place the strap (AC tap) in position and connect the stator leads (three screws).

Install the capacitor (where applicable).

## 8. Install the integral regulator:

Install the brush mounting screws (two) through the openings in the regulator body. Secure the regulator to the rear housing (two screws).

## 9. Install the brush assembly:

Insert the brush holder into the grooves in the hub of the rear housing. Place the D+ strap (or male terminal where applicable) on the stud and secure the brush holder with locknuts (two places). Secure the other end of the D+ strap.

## 10. Install the rear cover:

Be sure the felt gasket is in place (see illustration). Position the rear cover on the rear housing and secure it with two screws.

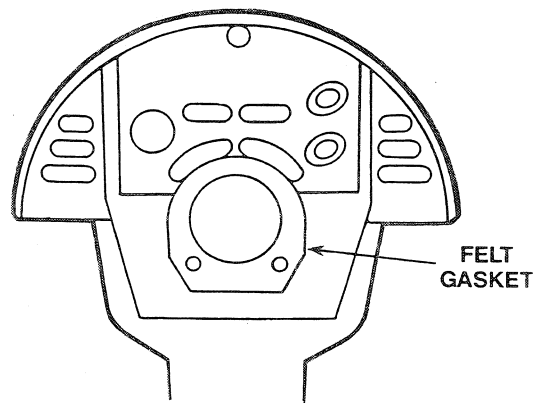

INSTALLING REAR COVER

## ALTERNATOR PERFORMANCE TESTS

The following tests will determine the current producing capability of the repaired alternator. Mount the alternator in a test fixture capable of providing 5000 alternator rpm. Select the required battery voltage and circuit polarity.

Turn the drive motor on, and adjust to obtain 5000 alternator rpm. Slowly reduce the field rheostat resistance; the alternator should develop a charge. Continue to reduce resistance until the alternator reaches its rated current output in amperes. **CAUTION:** Limit the output voltage to 15V maximum. **DO NOT** operate the alternator for more than a few minutes in this manner, due to the lack of voltage control. If the alternator will deliver its rated output, end the test.

Connect the fixture leads and instruments to the alternator terminals as shown in the following *TYPICAL ALTERNATOR PERFORMANCE TEST* diagram.

# PRESTOLITE ALTERNATOR SERVICE

The carbon pile or resistive load bank and ammeter must be capable of handling the alternator's rated output at rated rpm.

**CAUTION:** Make sure the connections are well secured and tight to avoid possible damage to the instruments, alternator or wiring due to short circuits.

Starting with the carbon pile off, slowly increase the load while observing the ammeter and maintaining 5000 rpm. Increase the load until a minimum output voltage of approximately 13.7 volts is obtained. Record the output current at this point, and refer to the chart for minimum acceptable ratings.

MINIMUM ACCEPTABLE OUTPUT VALUES AT 70° - 80°F (21° - 27° C)	
RATING	OUTPUT
51 AMP	46 AMP

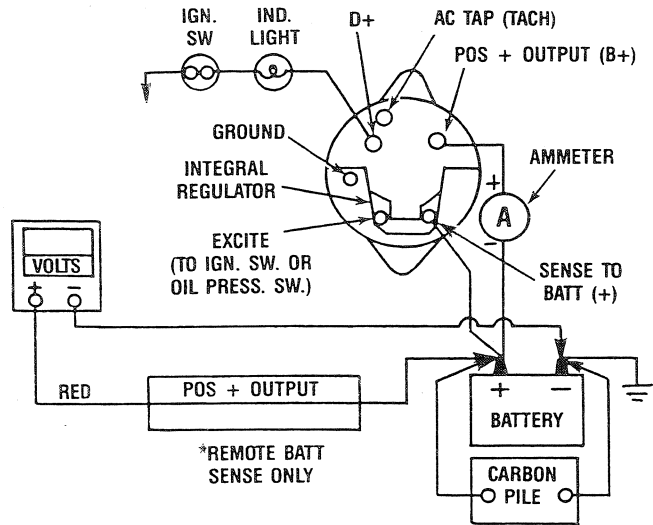

TYPICAL ALTERNATOR PERFORMANCE TEST

# DC ELECTRICAL SYSTEM

## WIRING DIAGRAM #39144

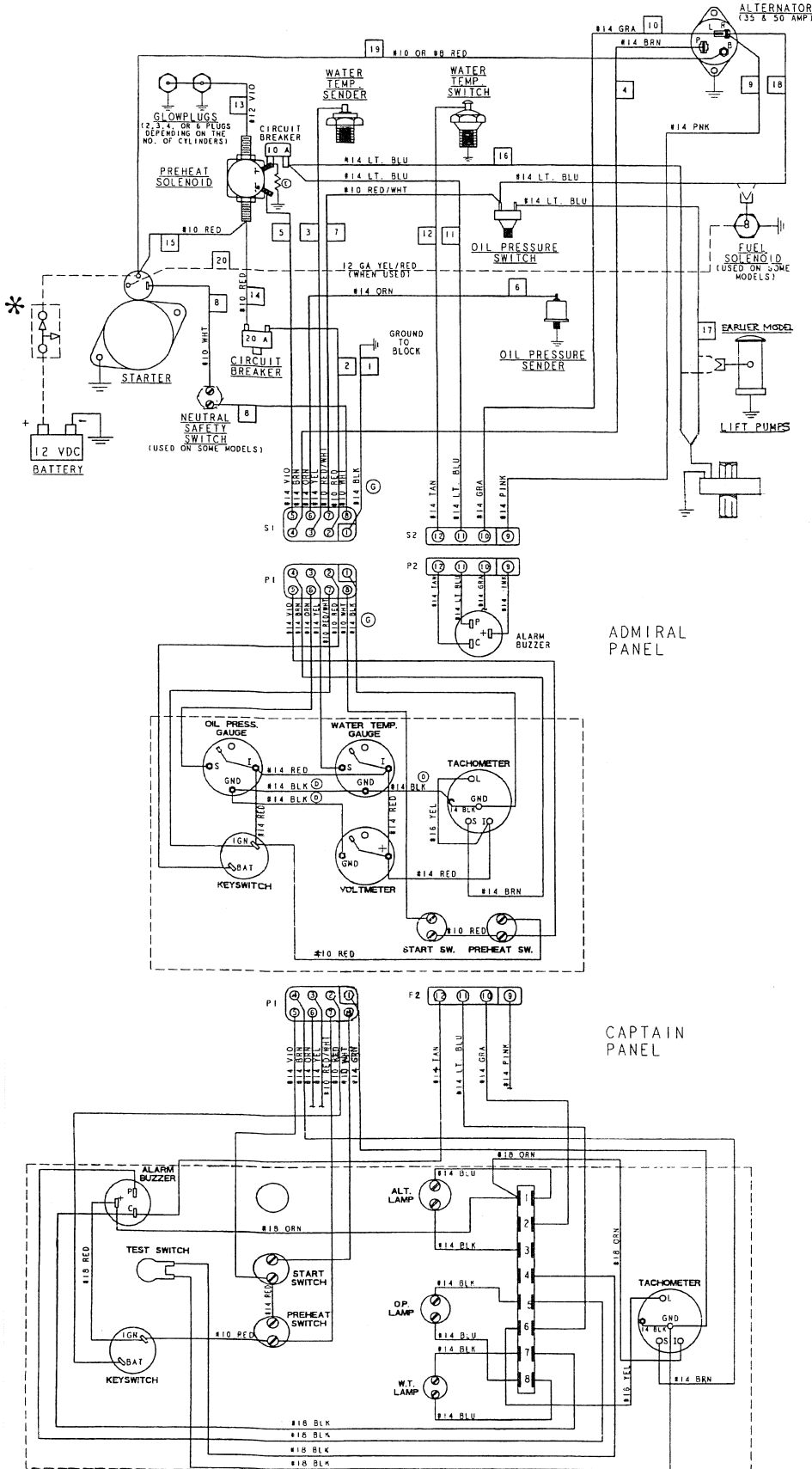

These diagrams illustrate the 12 volt negative ground electrical circuit. The two optional instrument panels, the CAPTAIN PANEL and the ADMIRAL PANEL are diagramed below.

When an ADMIRAL PANEL is installed, two additional instrument senders are assembled to the engine to provide data for the panel gauges (refer to the illustrations below).

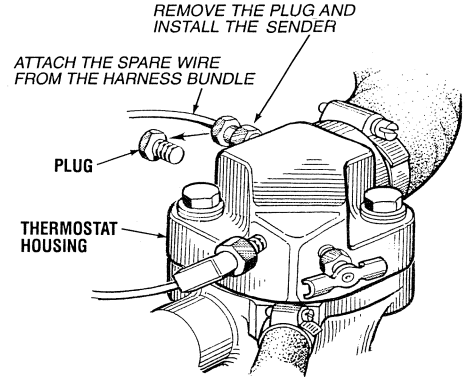

REMOVE THE PLUG AND INSTALL THE OIL PRESSURE SENDER

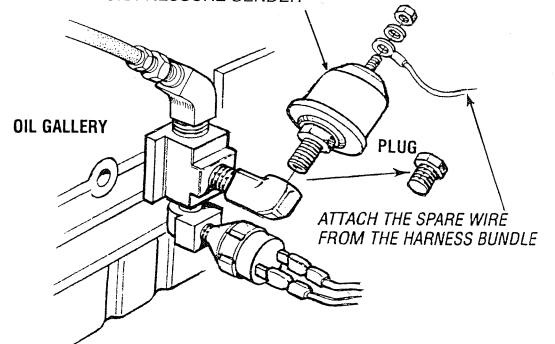

\* **NOTE:** An on-off switch should be installed in this circuit to disconnect the starter from the battery in an emergency and when leaving the boat. Twelve volt diesel engine starters typically draw 200 to 300 amps when cranking. A switch with a continuous rating of 175 amps at 12 VDC will normally serve this function, but a switch must never be used to "make" the starter circuit.

# DC ELECTRICAL SYSTEM

## WIRING SCHEMATIC #39144

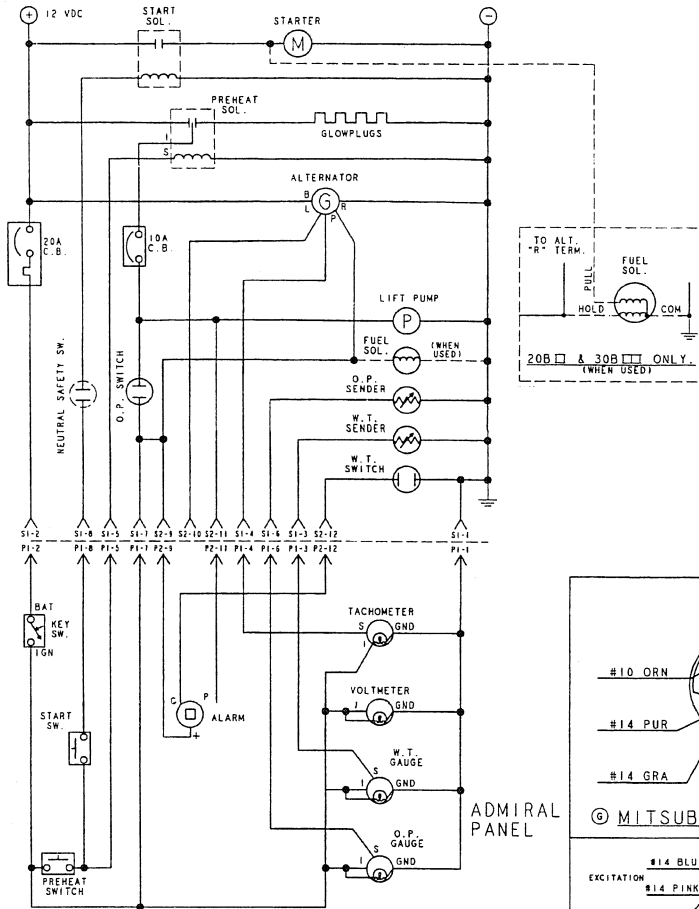

**NOTE:** An on-off switch should be installed in this circuit to disconnect the starter from the battery in an emergency and when leaving the boat. Twelve volt diesel engine starters typically draw 200 to 300 amps when cranking. A switch with a continuous rating of 175 amps at 12 VDC will normally serve this function, but a switch must never be used to "make" the starter circuit.

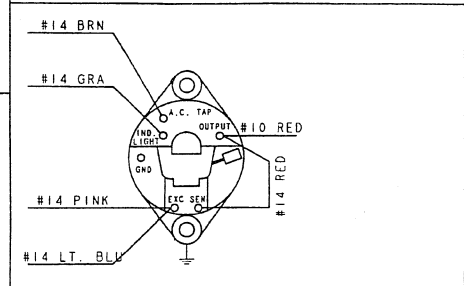
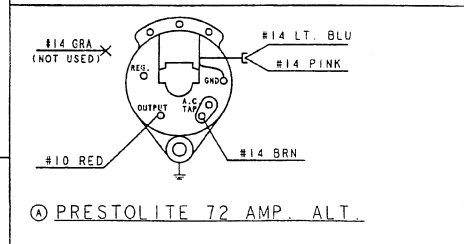
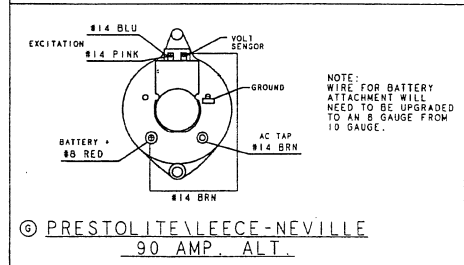
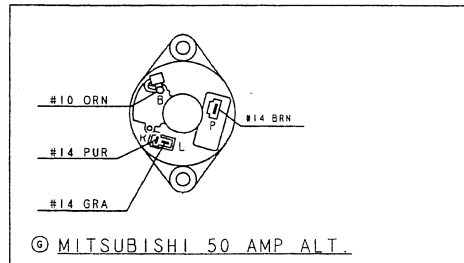
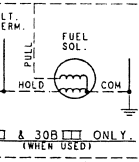
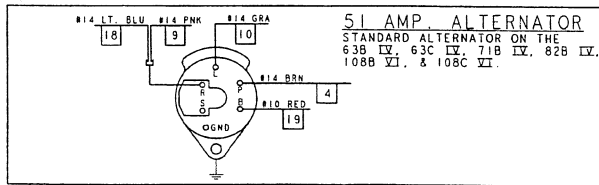
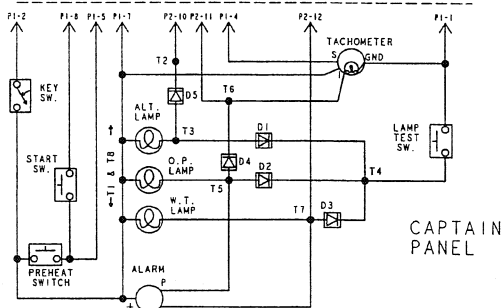

# DC ELECTRICAL SYSTEM

## WIRING DIAGRAM #200360 – CATALINA YACHTS

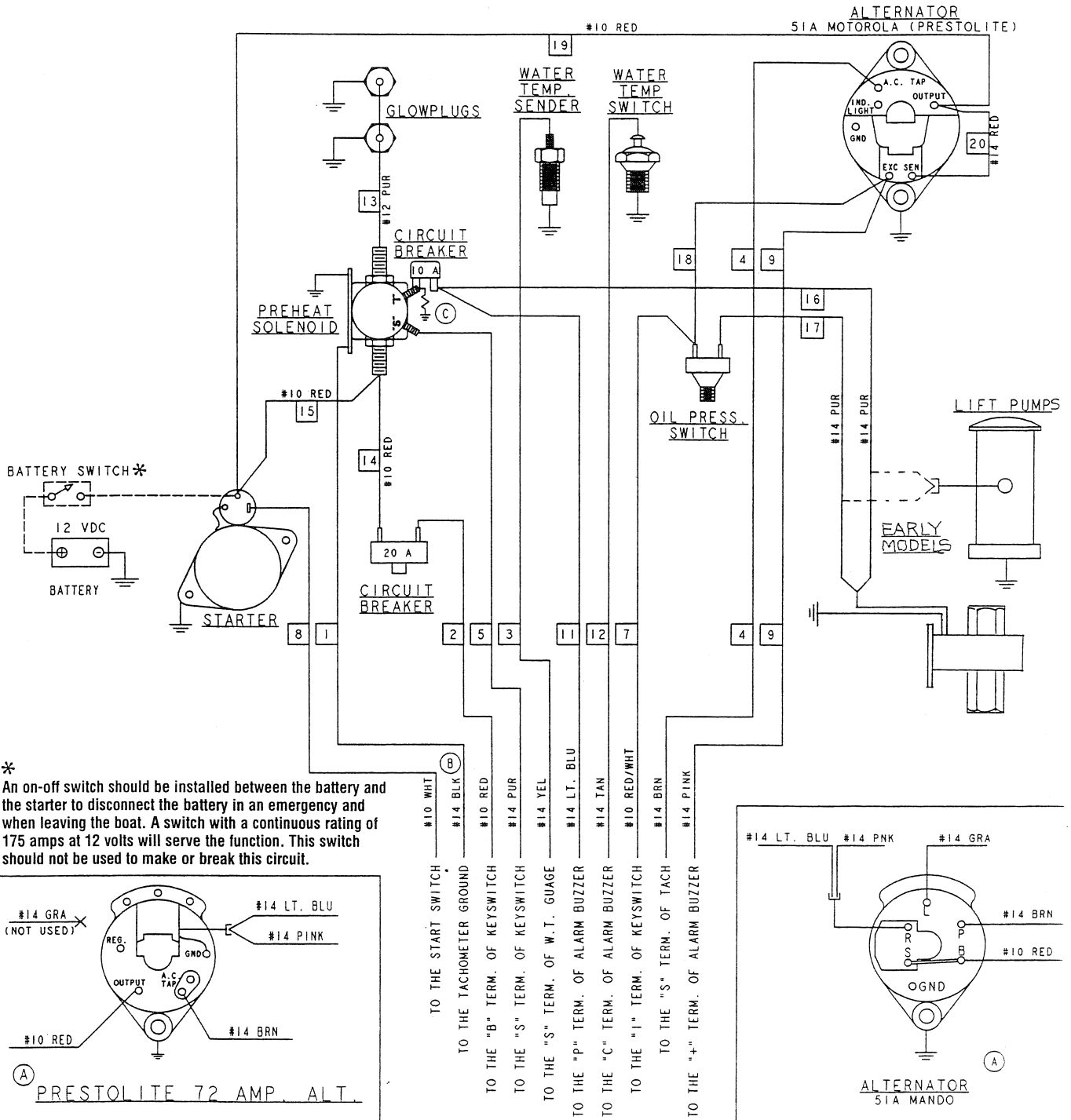

\* An on-off switch should be installed between the battery and the starter to disconnect the battery in an emergency and when leaving the boat. A switch with a continuous rating of 175 amps at 12 volts will serve the function. This switch should not be used to make or break this circuit.

# DC ELECTRICAL SYSTEM

## WIRING SCHEMATIC #200360 – CATALINA YACHTS

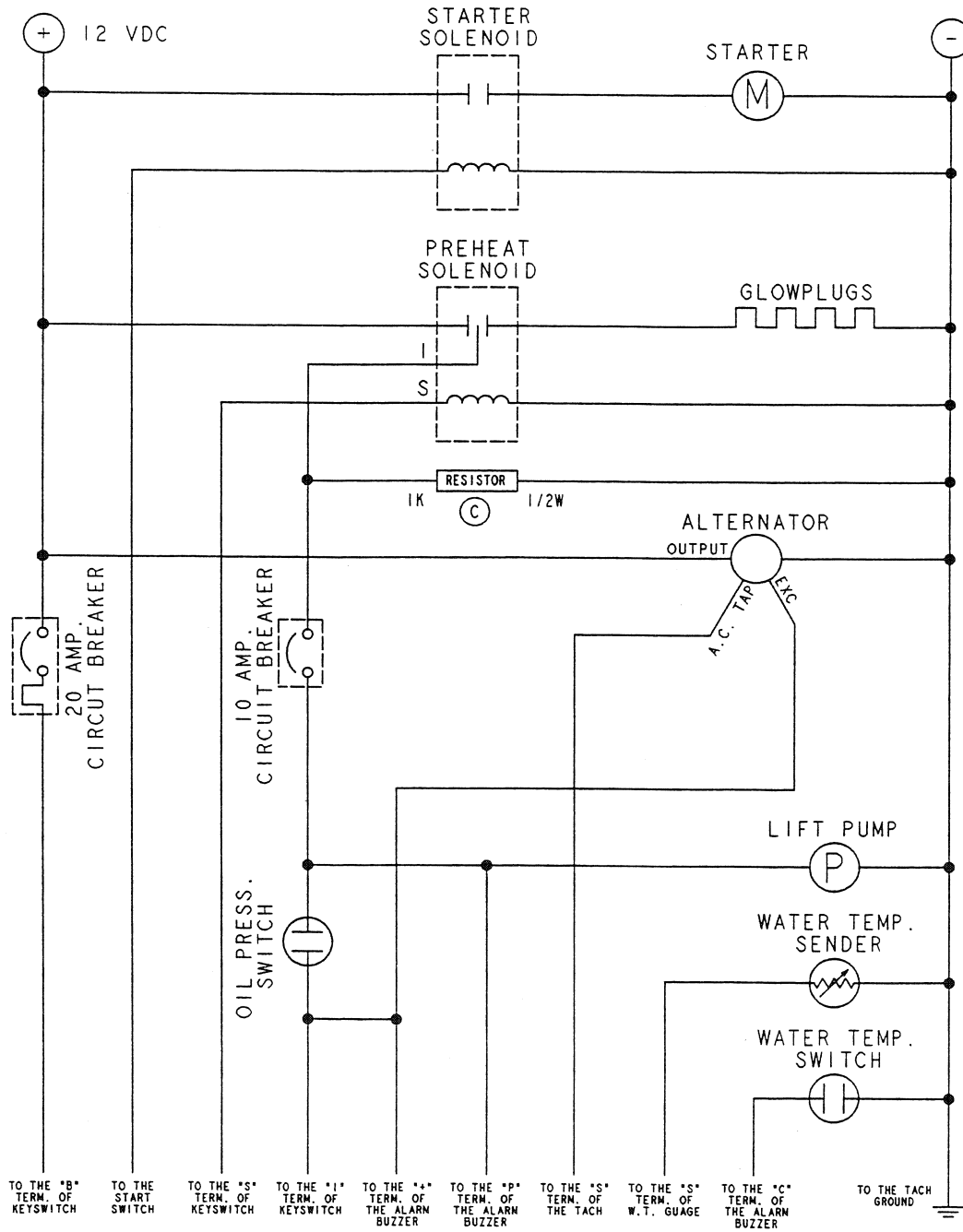

# HURTH HBW TRANSMISSIONS

## DESCRIPTION

The information below is specific to the HBW Transmissions; the *TRANSMISSION TROUBLESHOOTING SECTION* applies to all models.

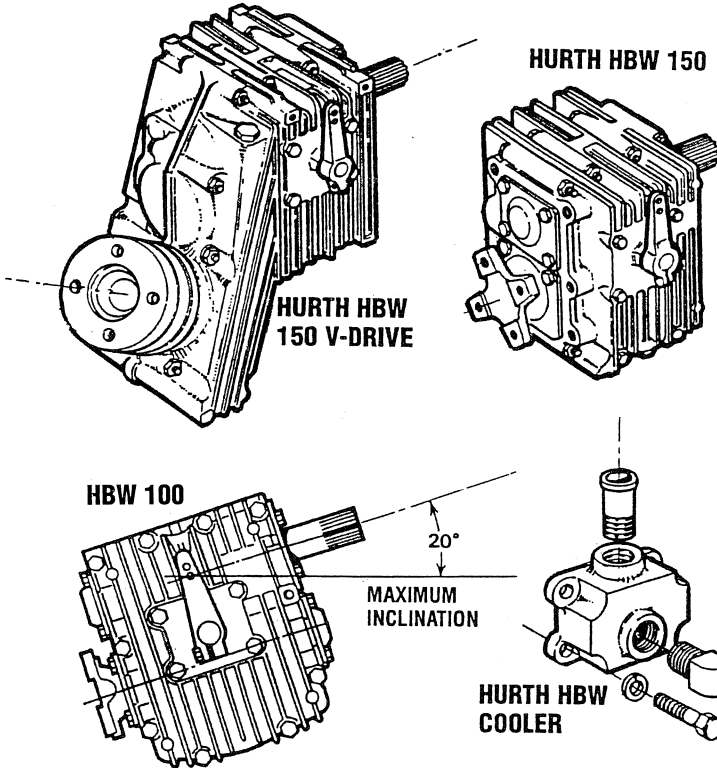

**CAUTION:** The position of the mechanism behind the actuating lever is factory-adjusted to ensure equal shift lever travel from neutral position A and B. If this mechanism is in any way tampered with, the transmission warranty will be void.

## SHAFT COUPLINGS

UNIVERSAL recommends a flexible connection between the transmission and the propeller shaft if the engine is flexibly mounted, in order to compensate for angular deflections. The installation of a special propeller thrust bearing is not required, since the propeller thrust will be absorbed by the transmission bearing, provided the value specified under *SPECIFICATIONS* is not exceeded. However, the output shaft should be protected from additional loads. Special care should be taken to prevent torsional vibration. When using a universal joint shaft, make certain to observe the manufacturers instructions.

Even with the engine solidly mounted, the use of flexible coupling or "DRIVESAVER" will reduce stress in the gear-box bearings caused by hull distortions, especially in wooden boats or where the distance between transmission output flange and stern gland is less than about 800mm.

"Drivesaver" is a product of Globe Marine Rockland, MA.

**NOTE:** When installing the transmission, make certain that shifting is not impeded by restricted movability of the cable or rod linkage, by unsuitably positioned guide sheaves, too small a bending radius or other restrictions. In order to mount a support for shift control cable connections, use the two threaded holes located above the cable bracket mounted on the gear housing. Refer to the *UNIVERSAL parts list*.

## SHIFT LEVER

The transmission is suitable for single lever remote control. Upon loosening the retaining screw, the actuating lever can be moved to any position required for the control elements (cable or rod linkage). Make certain that the shift lever does not contact the actuating lever cover plate: the minimum distance between lever and cover should be 0.5mm.

The control cable or rod should be arranged at right angle to the actuating shift lever when in the neutral position. The neutral position of the operating lever on the control console should coincide with the neutral position of this lever.

The shifting travel, as measured at the pivot point of the actuating lever, between the neutral position and end positions A and B should be at least 35mm for the outer and 30mm for the inner pivot point.

A greater amount of shift lever travel is in no way detrimental and is recommended. However, if the lever travel is shorter, proper clutch engagement might be impeded which, in turn, would mean premature wear, excessive heat generation and clutch plate failure. This would be indicated by slow clutch engagement or no engagement at all.

**NOTE** Check for proper lever travel at least each season.

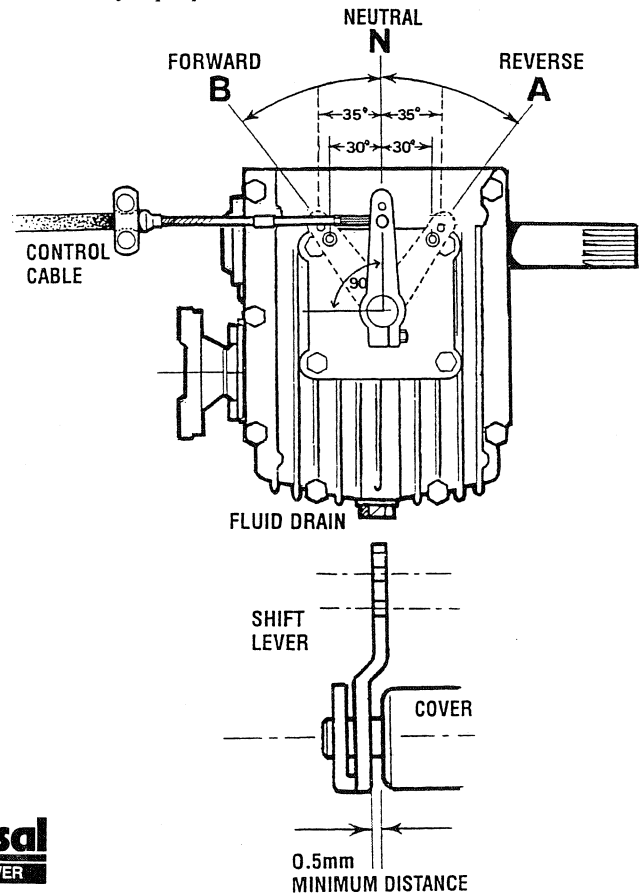



# HURTH HBW TRANSMISSIONS

## INITIAL OPERATION

All HBW marine transmissions are test-run on a test stand with the engine at the factory prior to delivery. For safety reasons the fluid is drained before shipment.

Fill the gearbox with Automatic Transmission Fluid (DEXTRON III). The fluid level should be up to the index mark on the dipstick. To check the fluid level, just insert the dipstick, do not screw it in. Screw the dipstick into the case after the fluid level is checked and tighten. Do not forget the sealing ring under the hexhead of the dipstick. Check for leaks and make a visual inspection of the coupling, oil cooler and hoses, and shift cables.

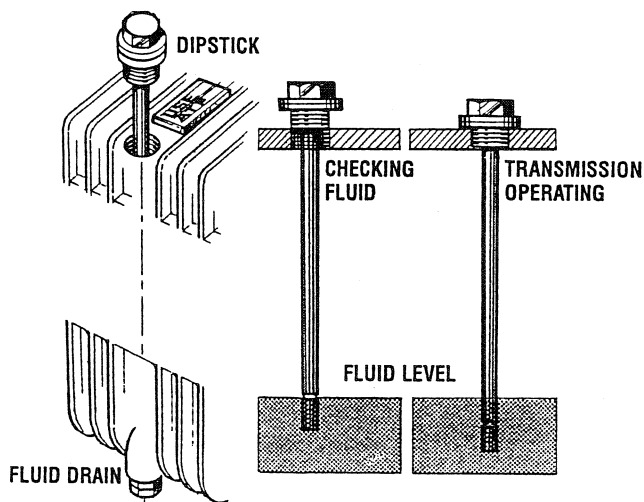

## FLUID CHANGE

Change the fluid for the first time after about 25 hours of operation, then every 250 operating hours or at least once a year or when you change engine oil.

### Removing the fluid

Push a suction pump hose down through the dipstick hole to the bottom of the housing and suck out the fluid. If space allows, use the transmission drain. Remove the drain plug from the bottom of the transmission and allow the fluid to drain into a container, then reinstall the plug with its sealing washer. Wipe down the transmission and properly dispose of the used fluid. After running the engine, shut down and recheck the fluid level.

**DRAIN PLUG TORQUE 20 - 25 ft/lbs**

**NOTE :** When changing the fluid, take care not to lose the drain plug sealing washer. The drain plug will leak without this sealing washer.

**WARNING:** Never pull out the dipstick while the engine is running. Hot fluid will splash from the dipstick hole. This could cause severe burns.

## LOCKING THE PROPELLER

Locking of the propeller shaft by an additional brake is not required: use the gear shift lever position opposite your direction of travel for this purpose. Never put the gear shift in the position corresponding to the direction of travel of the boat.

## WHEN UNDER SAIL OR BEING TOWED

Rotation of the propeller without load, such as when the boat is being sailed, being towed, or anchored in a river, as well as operation of the engine with the propeller stopped (for charging the battery), will have no detrimental effects on the transmission.

## DAILY OPERATION

- Check the transmission fluid.
- Visually check the gear shift linkage and transmission.
- Start the engine in neutral, allowing a few minutes at idle to warm the fluid.
- Shift into gear.

**NOTE :** Too low an idle speed will produce a chattering noise from the transmission gear and damper plate. In such cases the idle speed should be increased

For additional information refer to the following text in this Transmission Section: *SHAFT COUPLINGS, MAINTENANCE AND TRANSMISSION TROUBLESHOOTING.*

## HBW TRANSMISSIONS SPECIFICATIONS

<b>General</b>	(Hurth Standard Transmission) Case-hardened helical gears, with a servo-operated multiple disc clutch.
<b>Gear ratio forward (standard transmission)</b>	HBW-50 2.05:1 HBW-100 1.79:1 HBW-150 1.88:1
<b>Lubricating Fluid</b>	ATF - type A or Dextron - II or III
<b>Transmission Sump Capacity</b>	HBW-50 0.37 qt. (0.35 liter) HBW-100 0.37 qt. (0.35 liter) HBW-150 0.58 qt. (0.56 liter)
<b>Propeller Shaft Direction of Rotation</b>	Right hand - standard transmission

# HURTH HBW TRANSMISSIONS

## OPERATING TEMPERATURE

**⚠ WARNING:** *If the transmission fluid temperature is too high, stop the engine immediately and check the transmission fluid.*

Normal operating temperature of the transmission fluid should be in the range of 122°F (50°C) to 212°F (100°C). A maximum temperature of 266°F (130°C) may be only reached for a short time.

Make certain there is enough space around the transmission to provide good ventilation and cooling.

## TRANSMISSION COOLER

Coolers are standard equipment for the HBW 100, 125, 150, 150A, 150V, and the 250 (no cooler is necessary for the HBW 35 and 50).

The cooler is a separate part of the transmission which prevents any possibility of coolant diluting the transmission fluid. However, the continued flow of coolant thru the cooler will, in time, erode the inside of the cooler causing external leaks.

A transmission cooler may last ten years or more but, in some circumstances, depending on operating hours, tropical waters, maintenance, etc. it might only last half that time.

UNIVERSAL recommends having a spare cooler aboard.

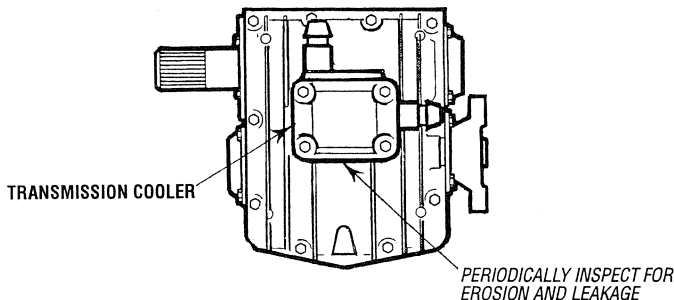

## MAINTENANCE

Transmission maintenance is minimal. Keep the exterior housing clean, check the fluid level as part of your regular routine, and change the fluid every 300 operating hours.

Periodically inspect the transmission and the cooler for leaks and corrosion. Lubricate the cable connections.

## Lay-up/Winterize

Storage requires special care. Follow these procedures:

- Drain water from the transmission oil cooler and replace with a proper mixture of antifreeze coolant.

**NOTE:** *This operation will normally occur when the engine raw water cooling system is properly winterized.*

- Clean up the transmission and touch up unpainted areas (use heat resistant paint).
- Fill the transmission with *Dextron III ATF* fluid to prevent internal corrosion (extended storage only, twelve months or more).
- Loosen attaching hardware from the transmission output flange and propeller shaft coupling flange before removing the boat from the water. Separate the flanges and spray with lubricant.
- Inspect the gear shift cable, linkage, and attachments. Look for corrosion of the end fittings, cracks or cuts in the conduit, and bending of the actuator rods. Lubricate all moving parts.

**NOTE:** *If the transmission is to be stored for a long time (twelve months or more), it should be topped off with fluid to prevent internal corrosion. Reduce the fluid level before putting the engine back into service.*

For additional information contact:

HURTH MARINE GEAR  
ZF Industries  
Marine US Headquarters  
3131 SW 42nd Street  
Fort Lauderdale, FL 33312  
Tel.: (954) 581-4040  
Fax: (954) 581-4077

# TRANSMISSION TROUBLESHOOTING [HURTH]

## CONTROL CABLES

The majority of transmission difficulties arise as a result of improper clutch adjustments (manual transmissions) or problems with control cables (hydraulic transmissions) rather than from problems with the transmission itself.

*HURTH* clutches, in particular, are very sensitive to improper shift adjustments.

If you experience operating problems with the transmission, shut the engine down. First check the transmission fluid level, then have a helper move the cockpit shift lever through the full range — from neutral to full forward, back to neutral, into full reverse, and back to neutral — while you observe the actuating lever on the transmission. If the remote is stiff to operate, break the cable loose at the transmission and try again. If it is still stiff, check the cable for kinks or excessively tight bends, and check any linkage for binding.

A new cable and perhaps a new linkage mechanism may be needed. While the cable is loose, shift the transmission in and out of gear using the lever on the side of the transmission to make sure there's no binding inside the case.

If the transmission passes these tests, crank the engine and have a helper put it in forward and reverse while you observe the propeller shaft; if the shaft isn't turning, the transmission needs professional attention. If it does turn but there's no thrust, check to see you still have a propeller on the end of the shaft or, if you have a folding or feathering propeller, that it isn't stuck in the "no pitch" position.

**NOTE:** *If you suspect a major problem in your transmission, immediately contact your UNIVERSAL dealer or an authorized marine transmission facility.*

Problem	Probable Cause	Verification/Remedy
Transmission gears cannot be shifted. Fails to move into gear.	<ol style="list-style-type: none"> <li>1. Shifting lever is loose.</li> <li>2. Shifting cable is broken, bent or unattached. Cable radius is too severe.</li> <li>3. Shift lever is binding against cover plate.</li> </ol>	<ol style="list-style-type: none"> <li>1. Tighten damping bolt on shifting lever.</li> <li>2. Check the cable, reattach or replace.</li> <li>3. Detach the shift cable and operate the lever by hand. Clearance should be 0.02 in (0.5mm).</li> </ol>
Transmission shifts into gear, but fails to propel the boat.	<ol style="list-style-type: none"> <li>1. Output coupling is not turning.</li> <li>2. Propeller shaft is not turning. Output coupling is turning.</li> <li>3. Output coupling and propeller shaft are both turning.</li> </ol>	<ol style="list-style-type: none"> <li>1. Transmission needs professional attention.</li> <li>2. The coupling bolts are sheared or the coupling is slipping on the propeller shaft. Tighten or replace set screws, keys, pins and coupling bolts as necessary.</li> <li>3. Inspect the propeller; it may be missing or damaged. A folding propeller may be jammed. A variable pitch propeller may be in "no pitch" position.</li> </ol>
Delay of gear engagement or engages only after an increase in speed.	<ol style="list-style-type: none"> <li>1. Lever travel <b>N</b> to <b>B</b> not equal to <b>N</b> to <b>A</b>. Refer to diagram.</li> <li>2. Shift lever travel is insufficient.</li> <li>3. Shift lever is binding against cover plate.</li> </ol>	<ol style="list-style-type: none"> <li>1. Adjust cover plate until the lever is exact mid position. Refer to <i>SHIFT LEVER TEXT AND DIAGRAM</i>.</li> <li>2. Check shift lever cable length. Refer to <i>SHIFT LEVER DIAGRAM</i>.</li> <li>3. Check clearance, adjust if necessary.</li> </ol>
Chattering transmission noise, mainly at low engine speed.	<ol style="list-style-type: none"> <li>1. The engine or propeller generates torsional vibrations in the drive unit which produces a "chattering" noise in the transmission.</li> </ol>	<ol style="list-style-type: none"> <li>1. Mount a flexible coupling with another stiffness factor between the transmission coupling and the driveshaft. A higher stiffness factor might be sufficient.</li> <li>2. Inspect the damper plate between the engine and the transmission. Replace if necessary.</li> </ol>
Transmission noise becomes louder.	<ol style="list-style-type: none"> <li>1. Damage starting on flexible coupling due to wear or fatigue, possibly due to misalignment between engine and the drive shaft.</li> <li>2. Beginning damage of bearings in transmission due to torsional vibrations, running without fluid, overload, wrong alignment of transmission, or excessive engine output.</li> </ol>	<ol style="list-style-type: none"> <li>1. Check alignment, inspect flexible coupling. If noise persists, inspect the damper plate between the transmission and the engine. Replace if necessary.</li> <li>2. Transmission needs professional attention.</li> </ol>
Boat fails to attain specified max speed.	<ol style="list-style-type: none"> <li>1. Operating temperature is high.</li> <li>2. Operating without cooling.</li> </ol>	<ol style="list-style-type: none"> <li>1. Wrong type of fluid, use ATF. Check fluid level.</li> <li>2. Check cooler. Inspect coolant hoses and coolant flow.</li> </ol>
Oil Leakage.	<ol style="list-style-type: none"> <li>1. Corrosion at radial sealing ring and shaft. Damaged sealing ring.</li> <li>2. Misalignment of output flanges.</li> </ol>	<ol style="list-style-type: none"> <li>1. Transmission needs professional attention.</li> <li>2. Check alignment. Must be within 0.003 in (0.08mm).</li> </ol>

**NOTE:** *If you suspect a major problem in your transmission, immediately contact your UNIVERSAL dealer or an authorized marine transmission facility.*

# SPECIAL TOOLS

The special tools shown in this section are not provided. Use the following plans and specifications for field fabrication.

## Valve Guide Replacing Tool

Application: Use to press out and to press fit the valve guide.

A	0.79 in. dia. (20 mm dia.)
B	0.460 – 0.468 in. dia. (11.7 – 11.9 mm dia.)
C	0.256 – 0.259 in. dia. (6.5 – 6.6 mm dia.)
D	8.86 in. (225 mm)
E	2.76 in. (70 mm)
F	1.77 in. (45 mm)
G	0.98 in. (25 mm)
H	0.197 in. (5 mm)
I	0.263 – 0.275 in. dia. (6.7 – 7.0 mm dia.)
J	0.787 in. dia. (20 mm dia.)
K	0.492 – 0.504 in. dia. (12.5 – 12.8 mm dia.)
L	0.350 – 0.358 in. (8.9 – 9.1 mm)
C1	Chamfer 0.039 in. (1.0 mm)
C2	Chamfer 0.079 in. (2.0 mm)
C0.3	Chamfer 0.012 in. (0.3 mm)

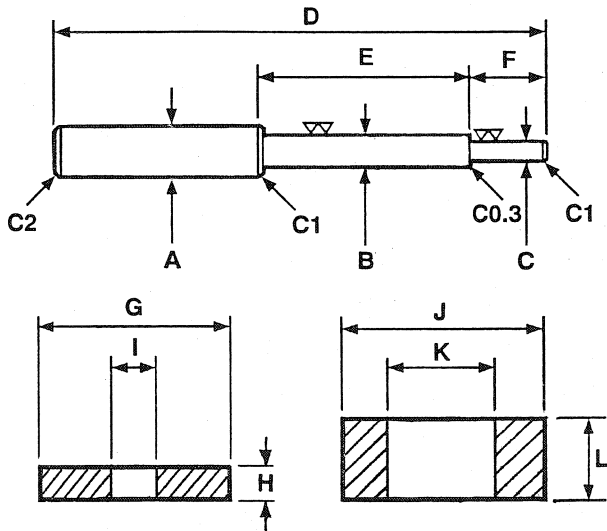

## Bushing Replacing Tool

Application: Use to press out and to press fit the bushing.

	FOR SMALL END BUSHING	FOR IDLER GEAR BUSHING
A	6.1811 in. (157 mm)	7.7165 in. (196 mm)
B	0.9449 in. (24 mm)	1.0236 in. (26 mm)
C	4.7244 in. (120 mm)	5.9055 in. (150 mm)
D	0.8583 – 0.8622 in. (21.8 – 21.9 mm)	1.0157 – 1.0197 in. (25.8 – 25.9 mm)
E	0.9764 – 0.9803 in. dia. (24.8 – 24.9 mm dia.)	1.0157 – 1.0197 in. dia. (25.8 – 25.9 mm dia.)
F	0.7874 in. (20 mm)	0.7874 in. (20 mm)
a	250 μin. (6.3 μm)	250 μin. (6.3 μm)
b	250 μin. (6.3 μm)	250 μin. (6.3 μm)

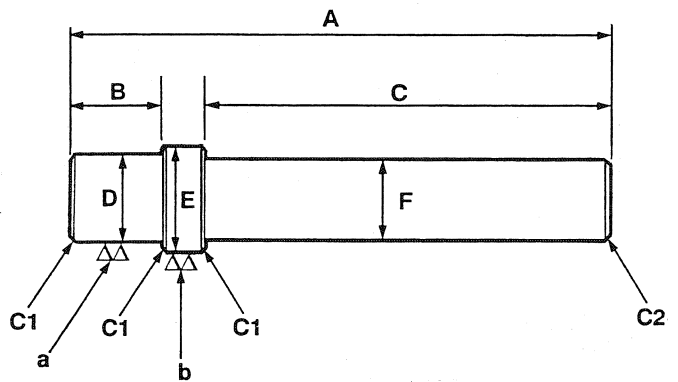

## Flywheel Stopper

Application: Use to loosen and tighten the flywheel screw.

A	7.87 in. (200 mm)
B	1.18 in. (30 mm)
C	0.79 in. (20 mm)
D	0.59 in. (15 mm)
E	0.59 in. (15 mm)
F	0.31 in. (8 mm)
G	0.39 in. (10 mm)

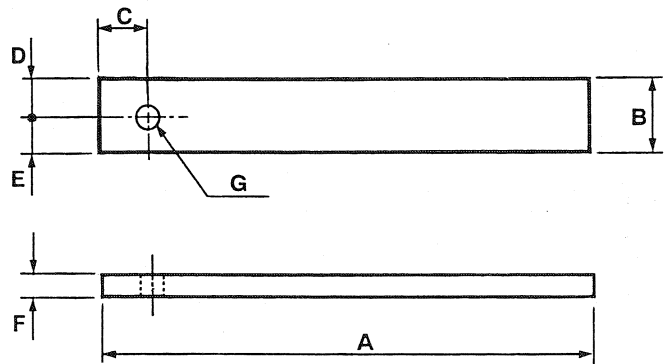

# SPECIAL TOOLS

## Crankshaft Bearing No. 1 Replacing Tool

Application: Use to press out and to press fit the crankshaft bearing No.1.

	PRESS OUT	PRESS FIT
A	5.31 in. (135 mm)	5.12 in. (130 mm)
B	2.83 in. (72 mm)	2.83 in. (72 mm)
C	1.57 rad. (40°)	1.57 rad. (40°)
D	0.39 in. (10 mm)	0.35 in. (9 mm)
E	0.79 in. (20 mm)	0.95 in. (24 mm)
F	0.79 in. (20 mm)	0.79 in. dia. (20 mm dia.)
G	2.2362 – 2.2402 in. dia. (56.0 – 56.9 mm dia.)	2.68 in. dia. (68 mm dia.)
H	2.0393 – 2.0433 in. dia. (51.8 – 51.9 mm dia.)	1.865 – 1.869 in. dia. (47.38 – 47.48 mm dia.)

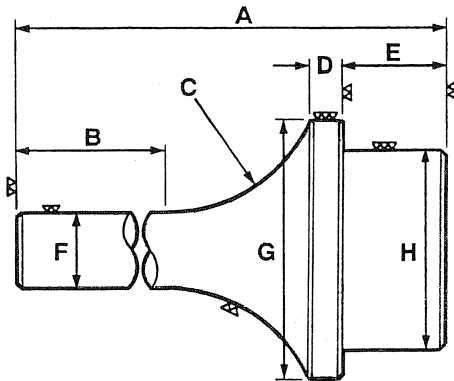

## Governor Gear Holder Bushing Replacing Tool

Application: Use to press out and to press fit the governor gear holder bushing.

A	7.4 in. (188 mm)
B	0.7 in. (18 mm)
C	5.9 in. (150 mm)
D	C1: Chamfer 0.039 in. (1.0 mm)
E	29.09 – 29.13 in. dia. (73.9 – 74.0 mm dia.)
F	2.748 – 2.751 in. dia. (69.8 – 69.9 mm dia.)
G	1.181 in. dia. (30 mm dia.)
H	C2: Chamfer 0.079 in. (2.0 mm)

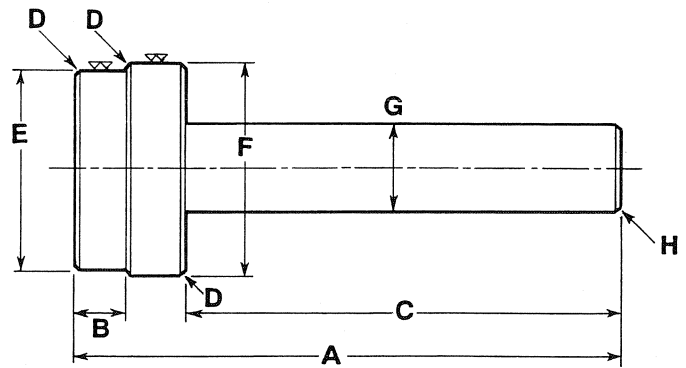

# TORQUES

**NOTE:** Screws, bolts and nuts must be tightened to the specified torque using a torque wrench. Some screws, bolts and nuts such as those used on the cylinder head must be tightened in a certain sequence and at the proper torque.

## Tightening Torques for Specific Engine Components

For “\*” marked screws, bolts and nuts in the table, apply engine oil to their threads and seats before tightening.

COMPONENT	SIZE x PITCH	ft-lb	kg-m	Nm
* Cylinder head cover cap nuts	M7 x 1.0	5.1 – 6.5	0.7 – 0.9	6.9 – 8.8
* Cylinder head bolts	M10 x 1.25	47.0 – 50.6	6.5 – 7.0	63.7 – 68.6
* Main bearing case bolts 1	M8 x 1.25	21.7 – 25.3	3.0 – 3.5	29.4 – 34.3
* Main bearing case bolts 2	M9 x 1.25	36.2 – 39.8	5.0 – 5.5	49.0 – 53.9
* Flywheel bolts	M10 x 1.25	39.8 – 43.4	5.5 – 6.0	53.9 – 58.8
* Connecting rod bolts	M8 x 1.0	30.4 – 34.0	4.2 – 4.7	41.2 – 46.1
* Rocker arm bracket nuts	M7 x 1.0	15.9 – 19.5	2.2 – 2.7	21.6 – 26.5
* Idler gear shaft bolts	M6 x 1.0	7.2 – 8.3	1.00 – 1.15	9.8 – 11.3
* Crankshaft end bolt	M14 x 1.5	173.6 – 180.8	24.0 – 25.0	235.4 – 245.2
* Bearing case cover screws	M6 x 1.0	7.2 – 8.3	1.00 – 1.15	9.8 – 11.3
Glow plugs	M8 x 1.0	5.8 – 10.8	0.8 – 1.5	7.8 – 14.7
Nozzle holder assembly	M20 x 1.5	36.2 – 50.6	5.0 – 7.0	49.0 – 68.6
Oil switch taper screw	PT 1/8	10.8 – 14.5	1.5 – 2.0	14.7 – 19.6
Injection line retaining nuts	M12 x 1.5	18.1 – 25.3	2.5 – 3.5	24.5 – 34.3
Overflow line assembly retaining nuts	M12 x 1.5	14.5 – 18.1	2.0 – 2.5	19.6 – 24.5
Starter's terminal <b>B</b> mounting nut	M8	6.5 – 8.7	0.9 – 1.2	8.8 – 11.8

\* Apply engine oil to threads and seats before tightening.

## Tightening Torques for General Use Screws, Bolts and Nuts

When the tightening torques are not specified, tighten the screws, bolts and nuts according to the following table.

NOMINAL DIAMETER	STANDARD SCREW AND BOLT GRADE 4			SPECIAL SCREW AND BOLT GRADE 7		
	ft-lb	kg-m	Nm	ft-lb	kg-m	Nm
M6	5.8 – 6.9	0.8 – 0.95	7.9 – 9.3	7.23 – 8.32	1.0 – 1.15	9.8 – 11.3
M8	13.0 – 15.2	1.8 – 2.1	17.7 – 20.6	17.4 – 20.3	2.4 – 2.8	23.5 – 27.5
M10	28.9 – 33.3	4.0 – 4.6	39.2 – 45.1	35.4 – 41.2	4.9 – 5.7	48.1 – 55.9
M12	46.3 – 53.5	6.4 – 7.4	62.8 – 72.6	57.1 – 66.5	7.9 – 9.2	77.5 – 90.2

Screw and bolt material grades are shown by numbers punched on the screw and bolt heads. Prior to tightening, be sure to check the numbers as shown below.

Punched Number	Screw and Bolt Material Grade
None or 4	Standard screw and bolt SS41, S20C
7	Special screw and bolt S43C, S48C (refined)

# STANDARD HARDWARE

## BOLT HEAD MARKINGS

Bolt strength classes are embossed on the head of each bolt.

**Customary (inch) bolts** are identified by markings two to grade eight (strongest). The marks correspond to two marks less than the actual grade, i.e., a grade seven bolt will display five embossed marks.

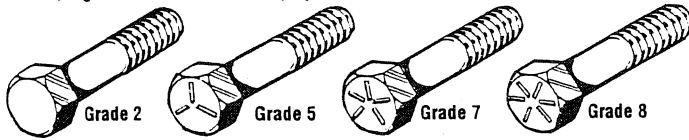

**Metric bolt** class numbers identify bolts by their strength with 10.9 the strongest.

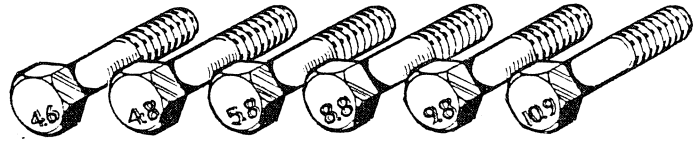

- NOTES:**
1. Use the torque values listed below when specific torque values are not available.
  2. These torques are based on clean, dry threads. Reduce torque by 10% when engine oil is used.
  3. Reduce torques by 30% or more, when threading capscrews into aluminum.

STANDARD BOLT & NUT TORQUE SPECIFICATIONS			
Capscrew Body Size (Inches) - (Thread)	SAE Grade 5 Torque Ft-Lb (Nm)	SAE Grade 6-7 Torque Ft-Lb (Nm)	SAE Grade 8 Torque Ft-Lb (Nm)
1/4 - 20 - 28	8 (11) 10 (14)	10 (14)	12 (16) 14 (19)
5/16 - 18 - 24	17 (23) 19 (26)	19 (26)	24 (33) 27 (37)
3/8 - 16 - 24	31 (42) 35 (47)	34 (46)	44 (60) 49 (66)
7/16 - 14 - 20	49 (66) 55 (75)	55 (75)	70 (95) 78 (106)
1/2 - 13 - 20	75 (102) 85 (115)	85 (115)	105 (142) 120 (163)
9/16 - 12 - 18	110 (149) 120 (163)	120 (163)	155 (210) 170 (231)
5/8 - 11 - 18	150 (203) 170 (231)	167 (226)	210 (285) 240 (325)
3/4 - 10 - 16	270 (366) 295 (400)	280 (380)	375 (508) 420 (569)
7/8 - 9 - 14	395 (536) 435 (590)	440 (597)	605 (820) 675 (915)
1 - 8 - 14	590 (800) 660 (895)	660 (895)	910 (1234) 990 (1342)

METRIC BOLT & NUT TORQUE SPECIFICATIONS					
Bolt Dia.	Wrench Size	Grade 4.6 Ft-Lb (Nm)	Grade 4.8 Ft-Lb (Nm)	Grade 8.8 - 9.8 Ft-Lb (Nm)	Grade 10.9 Ft-Lb (Nm)
M3	5.5 mm	0.3 (0.5)	0.5 (0.7)	1 (1.3)	1.5 (2)
M4	7 mm	0.8 (1.1)	1 (1.5)	2 (3)	3 (4.5)
M5	8 mm	1.5 (2.5)	2 (3)	4.5 (6)	6.5 (9)
M8	10 mm	3 (4)	4 (5.5)	7.5 (10)	11 (15)
M9	13 mm	7 (9.5)	10 (13)	18 (25)	35 (26)
M10	16 mm	14 (19)	18 (25)	37 (50)	55 (75)
M12	18 mm	26 (35)	33 (45)	63 (85)	97 (130)
M14	21 mm	37 (50)	55 (75)	103 (140)	151 (205)
M16	24 mm	59 (80)	85 (115)	159 (215)	232 (315)
M18	27 mm	81 (110)	118 (160)	225 (305)	321 (435)
M20	30 mm	118 (160)	166 (225)	321 (435)	457 (620)
M22	33 mm	159 (215)	225 (305)	435 (590)	620 (840)
M24	36 mm	203 (275)	288 (390)	553 (750)	789 (1070)
M27	41 mm	295 (400)	417 (565)	811 (1100)	1154 (1565)
M30	46 mm	402 (545)	568 (770)	1103 (1495)	1571 (2130)
M33	51 mm	546 (740)	774 (1050)	1500 (2035)	2139 (2900)
M36	55 mm	700 (950)	992 (1345)	1925 (2610)	2744 (3720)

## SEALANTS & LUBRICANTS

### GASKETS/SEALANTS

Oil based PERMATEX #2 and it's HIGH TACK equivalent are excellent all purpose sealers. They are effective in just about any joint in contact with coolant, raw water, oil or fuel.

A light coating of OIL or LIQUID TEFLON can be used on rubber gaskets and O-rings.

LOCTITE hydraulic red sealant should be used on oil adapter hoses and the oil filter assembly.

Coat both surfaces of the oil pan gasket with high temp RED SILICONE sealer.

When installing gaskets that seal around water (coolant) passages, coat both sides with WHITE SILICONE grease.

High-copper ADHESIVE SPRAYS are useful for holding gaskets in position during assembly.

Specialized gasket sealers such as HYLOMAR work well in applications requiring non-hardening properties. HYLOMAR is particularly effective on copper cylinder-head gaskets as it resists fuel, oil and water.

Use LIQUID TEFLON for sealing pipe plugs and fillings that connect coolant passages. **Do not use tape sealants!**

### BOLTS & FASTENERS/ASSEMBLIES

Lightly oil head bolts and other fasteners as you assemble them. Bolts and plugs that penetrate the water jacket should be sealed with PERMATEX #2 or HIGH TACK.

When assembling the flywheel, coat the bolt threads with LOCTITE blue.

Anti-seize compounds and thread locking adhesives such as LOCTITE protect threaded components yet allows them to come apart when necessary.

LOCTITE offers levels of locking according to the job.

LITHIUM based grease is waterproof, ideal for water pump bearings and stuffing boxes.

Heavily oil all sliding and reciprocating components when assembling. **Always use clean engine oil!**

# METRIC CONVERSIONS

## INCHES TO MILLIMETERS

## MILLIMETERS TO INCHES

Inches	mm	Inches	mm	mm	Inches	mm	Inches
1	25.40	15	381.00	1	0.0394	15	0.5906
2	50.80	20	508.00	2	0.0787	20	0.7874
3	76.20	25	635.00	3	0.1181	25	0.9843
4	101.60	30	762.00	4	0.1575	30	1.1811
5	127.00	35	889.00	5	0.1969	35	1.3780
10	254.00	40	1016.00	10	0.3937	40	1.5748

10 MILLIMETERS = 1 CENTIMETER, 100 CENTIMETERS = 1 METER = 39.37 INCHES (3.3 FEET)

## INCHES TO METERS

## METERS TO INCHES

Inches	Meters	Inches	Meters	Meters	Inches	Meters	Inches
1	0.0254	7	0.1778	0.1	3.937	0.7	27.559
2	0.0508	8	0.2032	0.2	7.874	0.8	31.496
3	0.0762	9	0.2286	0.3	11.811	0.9	35.433
4	0.1016	10	0.2540	0.4	15.748	1.0	39.370
5	0.1270	11	0.2794	0.5	19.685	1.1	43.307
6	0.1524	12	0.3048	0.6	23.622	1.2	47.244

TO CONVERT METERS TO CENTIMETERS, MOVE DECIMAL POINT TWO PLACES TO THE RIGHT

## YARDS TO METERS

## METERS TO YARDS

Yards	Meters	Yards	Meters	Meters	Yards	Meters	Yards
1	0.91440	6	5.48640	1	1.09361	6	6.56168
2	1.82880	7	6.40080	2	2.18723	7	7.65529
3	2.74320	8	7.31520	3	3.28084	8	8.74891
4	3.65760	9	8.22960	4	4.37445	9	9.84252
5	4.57200	10	9.14400	5	5.46807	10	10.93614

MOVE DECIMAL POINT FOR HIGHER VALUES — e.g. 6,000 METERS = 6,561.68 YARDS

## POUNDS TO KILOGRAMS

## KILOGRAMS TO POUNDS

lb	kg	lb	kg	kg	lb	kg	lb
1	0.454	6	2.722	1	2.205	6	13.228
2	0.907	7	3.175	2	4.409	7	15.432
3	1.361	8	3.629	3	6.614	8	17.637
4	1.814	9	4.082	4	8.818	9	19.842
5	2.268	10	4.536	5	11.023	10	22.046

## GALLONS TO LITERS

## LITERS TO GALLONS

Gallons	Liters	Gallons	Liters	Liters	Gallons	Liters	Gallons
1	3.79	10	37.86	1	0.26	60	15.66
2	7.57	20	75.71	2	0.53	90	23.77
3	11.36	30	113.57	5	1.32	120	31.32
4	15.14	40	151.42	10	2.64	150	39.62
5	18.93	50	189.28	20	5.28	180	47.54

## PINTS TO LITERS

## LITERS TO PINTS

Pints	Liters	Pints	Liters	Liters	Pints	Liters	Pints
1	0.47	6	2.84	1	2.11	6	12.68
2	0.95	7	3.31	2	4.23	7	14.79
3	1.42	8	3.79	3	6.34	8	16.91
4	1.89	9	4.26	4	8.45	9	19.02
5	2.37	10	4.73	5	10.57	10	21.13

## TEMPERATURE

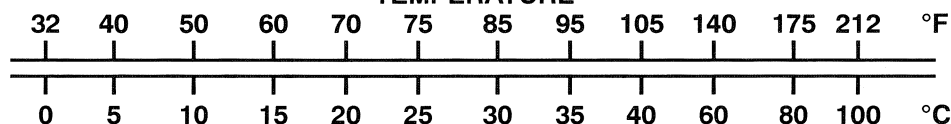



# STANDARD AND METRIC CONVERSION DATA

## LENGTH-DISTANCE

Inches (in) x 25.4 = Millimeters (mm) x .0394 = Inches

Feet (ft) x .305 = Meters (m) x 3.281 = Feet

Miles x 1.609 = Kilometers (km) x .0621 = Miles

## VOLUME

Cubic Inches (in<sup>3</sup>) x 16.387 = Cubic Centimeters x .061 = in<sup>3</sup>

Imperial Pints (IMP pt) x .568 = Liters (L) x 1.76 = IMP pt

Imperial Quarts (IMP qt) x 1.137 = Liters (L) x .88 = IMP qt

Imperial Gallons (IMP gal) x 4.546 = Liters (L) x .22 = IMP gal

Imperial Quarts (IMP qt) x 1.201 = US Quarts (US qt) x .833 = IMP qt

Imperial Gallons (IMP gal) x 1.201 = US Gallons (US gal) x .833 = IMP gal

Fluid Ounces x 29.573 = Milliliters x .034 = Ounces

US Pints (US pt) x .473 = Liters(L) x 2.113 = Pints

US Quarts (US qt) x .946 = Liters (L) x 1.057 = Quarts

US Gallons (US gal) x 3.785 = Liters (L) x .264 = Gallons

## MASS-WEIGHT

Ounces (oz) x 28.35 = Grams (g) x .035 = Ounces

Pounds (lb) x .454 = Kilograms (kg) x 2.205 = Pounds

## PRESSURE

Pounds Per Sq In (psi) x 6.895 = Kilopascals (kPa) x .145 = psi

Inches of Mercury (Hg) x .4912 = psi x 2.036 = Hg

Inches of Mercury (Hg) x 3.377 = Kilopascals (kPa) x .2961 = Hg

Inches of Water (H<sub>2</sub>O) x .07355 = Inches of Mercury x 13.783 = H<sub>2</sub>O

Inches of Water (H<sub>2</sub>O) x .03613 = psi x 27.684 = H<sub>2</sub>O

Inches of Water (H<sub>2</sub>O) x .248 = Kilopascals (kPa) x 4.026 = H<sub>2</sub>O

## TORQUE

Pounds-Force Inches (in-lb) x .113 = Newton Meters (Nm) x 8.85 = in-lb

Pounds-Force Feet (ft-lb) x 1.356 = Newton Meters (Nm) x .738 = ft-lb

## VELOCITY

Miles Per Hour (MPH) x 1.609 = Kilometers Per Hour (KPH) x .621 = MPH

## POWER

Horsepower (Hp) x .745 = Kilowatts (Kw) x 1.34 = MPH

## FUEL CONSUMPTION

Miles Per Hour IMP (MPG) x .354 = Kilometers Per Liter (Km/L)

Kilometers Per Liter (Km/L) x 2.352 = IMP MPG

Miles Per Gallons US (MPG) x .425 = Kilometers Per Liter (Km/L)

Kilometers Per Liter (Km/L) x 2.352 = US MPG

## TEMPERATURE

Degree Fahrenheit (°F) = (°C X 1.8) + 32

Degree Celsius (°C) = (°F - 32) x .56

# INDEX

Admiral Control Panel.....	63, 94	Exhaust Manifold.....	22, 47
Air Intake Silencer.....	23	Flywheel.....	20, 22, 30
Alternator.....	23	Fuel Camshaft.....	19, 26
Mando.....	72	Fuel System	
Prestolite.....	82	Description.....	56
Alternator Bracket.....	23	Disassembly.....	60
Anode, Zinc.....	53	Filter.....	56, 58
Back Plate.....	22	Injection Nozzle.....	57, 60, 62
Bearing Case Cover.....	30	Injection Pump.....	56, 60, 61
Bellhousing.....	22	Injectors.....	23, 24, 56, 62
Belt Adjustment.....	45	Lift Pump.....	56, 58
Camshaft.....	19, 35	Reassembly.....	60
Camshaft Gear.....	28	Return Lines.....	23, 56
Captain Control Panel.....	64, 94	Service.....	61
Compression Test.....	6, 44	Gear Case.....	25
Connecting Rod.....	19, 28, 29, 36, 37	Gears.....	28
Control Panel – Admiral.....	63, 94	Glow Plug.....	67
Control Panel – Captain.....	64, 94	Governor.....	58
Control Panel Troubleshooting.....	65, 66	Fork Lever.....	27
Coolant Pump.....	25, 52, 55	Shaft.....	27
Coolant Recovery Tank.....	53	Heat Exchanger.....	22, 53
Cooling System		Hourmeter.....	63
Description.....	52	Hurth HBW Transmissions.....	98
Service.....	54	Idler Gear Bushing.....	36
Crankcase Breather Hose.....	23	Idler Gear No. 1.....	28, 35
Crankshaft.....	18, 30, 38	Idle Speed Adjustment.....	46, 65
Crankshaft Bearing No. 1.....	40	Injection Pump.....	26, 56
Cylinder.....	41, 42	Intake Manifold.....	23
Cylinder Block.....	18	Key Switch.....	63, 64
Cylinder Head.....	18, 23, 24, 32	Lubrication System	
Cylinder Head Bolts.....	43	Description.....	48
Cylinder Head Cover.....	24	Service.....	50
Damper Plate.....	22	Main Bearing Case Assembly.....	31
DC Electrical System.....	94	Mando Alternator Service.....	72
DC Voltmeter.....	63	Metric Conversions.....	106, 107
Drive Belt Adjustment.....	45	Nozzle Holder Assembly.....	23, 57, 60, 62
Engine		Oil	
Adjustments.....	43	Filter.....	49
Description.....	18	Pan.....	28
Disassembly.....	21, 22	Pan Filter.....	28
Overhaul.....	2	Pressure.....	44, 50
Parts Identification.....	3	Pressure Alarm.....	63
Reassembly.....	21, 22	Pressure Gauge.....	63, 66
Service.....	32	Pressure Sender.....	50, 94
Specifications.....	4	Pressure Switch.....	49, 50
Troubleshooting.....	7	Pump.....	49, 50

(continued)

# INDEX

Oil Clearance	
Camshaft Journal.....	36
Crankpin – Crankpin Bearing.....	38
Crankshaft Journal – Crankshaft Bearing No. 1.....	39
Crankshaft Journal – Crankshaft Bearings No. 2 & No. 3.....	40
Idle Gear Shaft – Idle Gear Bushing.....	36
Piston Pin – Connecting Rod Small End Bushing.....	36
Rocker Arm Shaft – Bearing.....	34
Tappet – Tappet Guide Bore.....	35
Parts Identification.....	3
Piston and Piston Rings.....	18, 28, 29, 36, 37
Preheat Button.....	63, 64
Prestolite Alternator Service.....	82
Pumps	
Coolant.....	25, 52, 55
Fuel Lift.....	56, 58
Injection.....	56, 60, 61
Oil.....	50
Raw Water.....	52, 54
Push Rod.....	24, 34
Raw Water Pump.....	52, 54
Relief Valve.....	49
Rocker Arm and Shaft.....	19, 24, 34
RPM Gauge.....	63, 64
Sealants and Lubricants.....	105
Service Standards.....	15
Special Tools.....	102
Specifications.....	4
Speed Control Pate.....	25
Standard Hardware.....	105
Start Button.....	63, 64
Starter Motor.....	22, 30, 68
Starter Service.....	68
Stop Solenoid.....	25
Tachometer.....	46, 63, 64, 65
Tappets.....	24, 35
Test Button.....	64
Testing for Overhaul.....	6
Thermostat.....	23, 52, 54, 94
Timing Gears.....	35
Top Clearance.....	43
Torques	
Standard Hardware.....	105
Universal Engine.....	104
Transmission – Hurth HBW.....	21, 98
Damper Plate.....	22
Oil Coolers.....	100
Removal.....	22
Specifications.....	99
Troubleshooting.....	101
Troubleshooting	
Control Panel.....	67
Engine.....	7
Transmission.....	101
Valves.....	23, 25
Clearance Adjustment.....	43
Guide.....	34
Lapping.....	33
Recession.....	32
Seating.....	33
Spring.....	34
Stem to Valve Guide Clearance.....	32
Water Temperature	
Alarm.....	63
Gauge.....	63, 66
Sender.....	52, 94
Switch.....	52
Wiring Diagrams/Schematics	
Wiring Diagram #39144.....	94
Wiring Schematic #39144.....	95
Wiring Diagram #200360 – Catalina Yachts.....	96
Wiring Schematic #200360 – Catalina Yachts.....	97
Zinc Anode.....	53

